

BARIKELL

SPARE PART LIST MANUAL *MANUALE ELENCO PARTI DI RICAMBIO*

RIDE ON TROWEL MK8-120 / MK10-120 HCS GASOLINE
FRATTAZZATRICE MK8-120 / MK10-120 HCS BENZINA

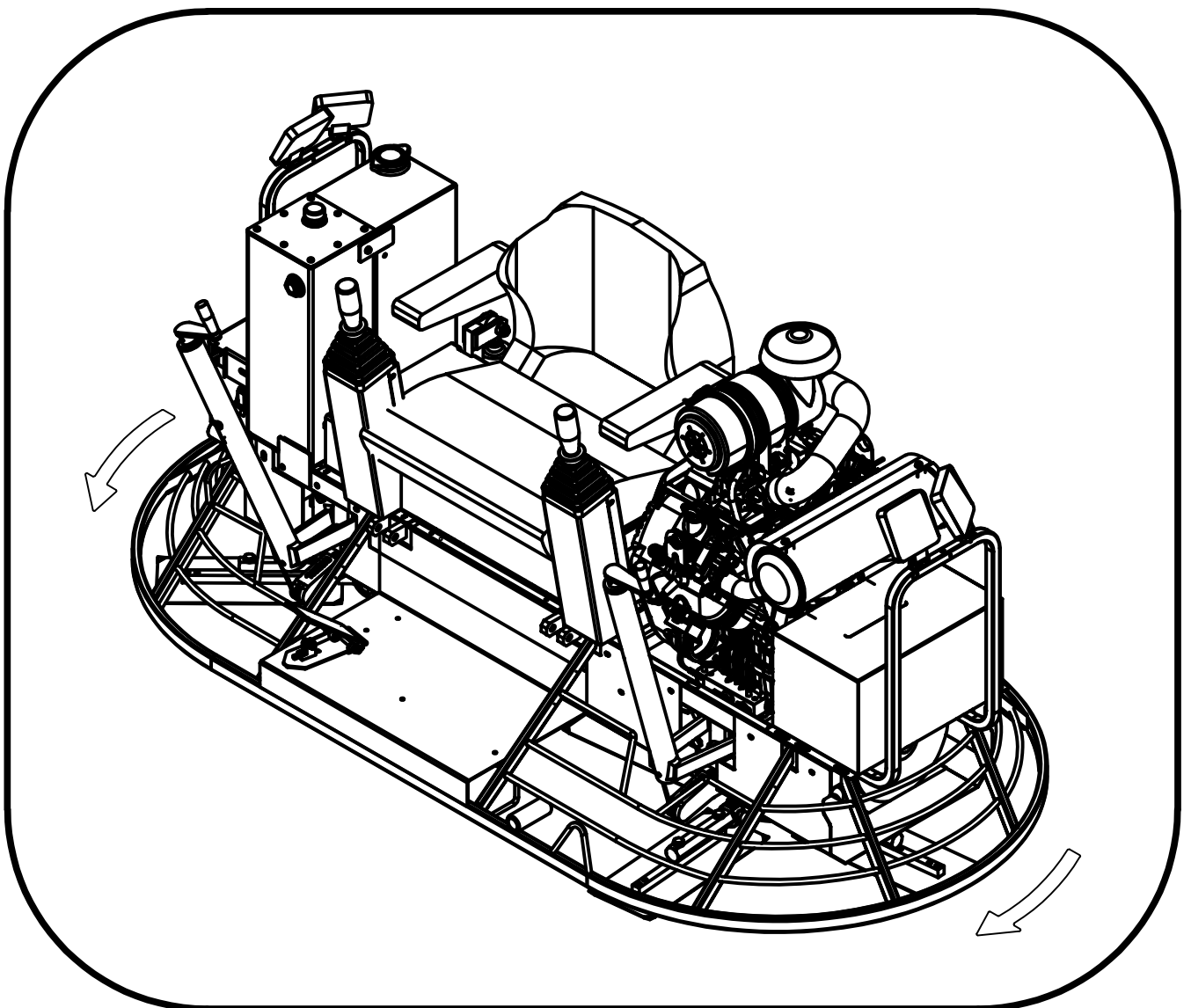



MK8-120 HCS **MK10-120 HCS**

TABLE A
TAVOLA

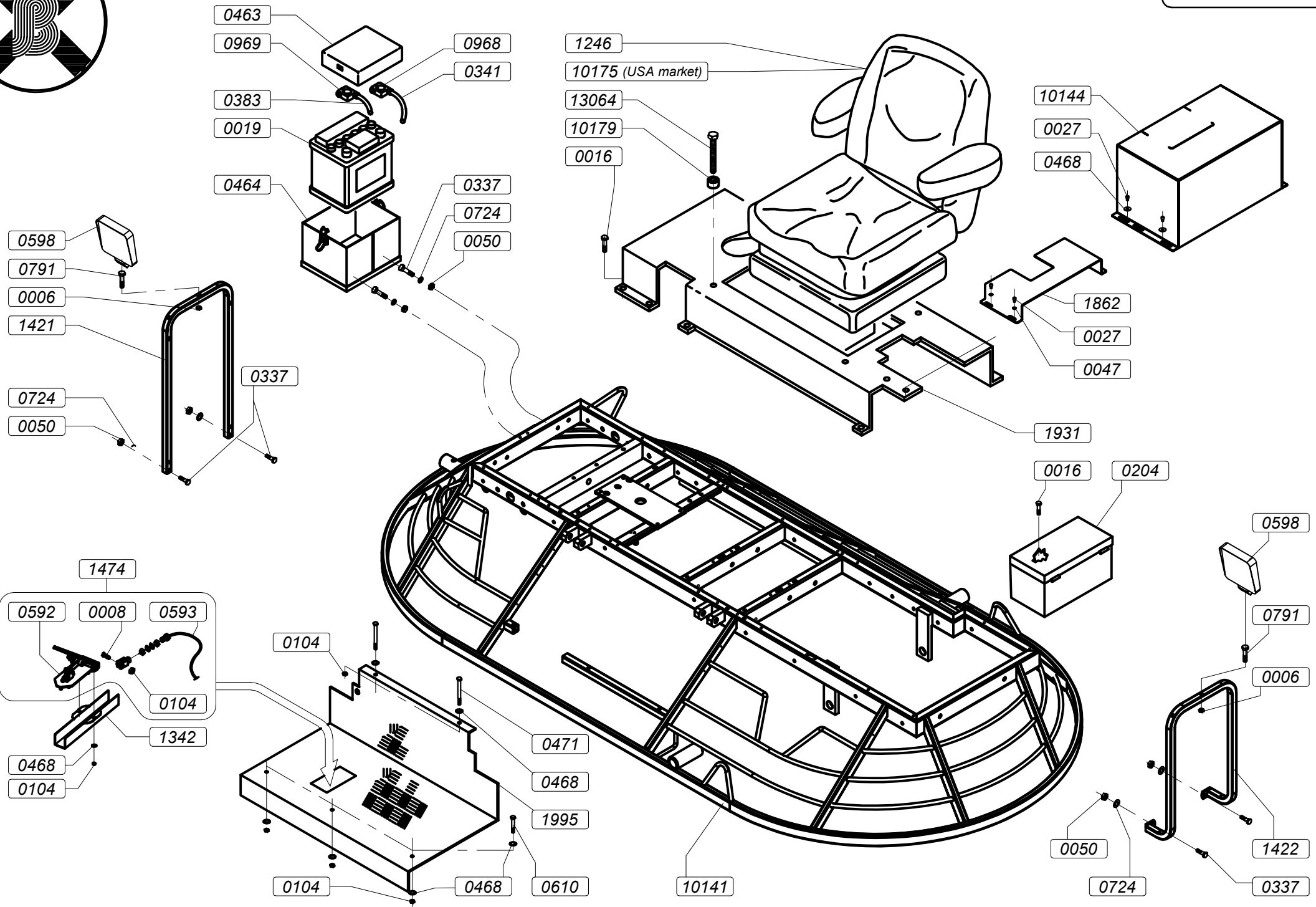

COD.	DESCRIZIONE (I)	DESCRIPTION (GB)
0006	DADO M8 UNI 5588 Z.B.	NUT M8 UNI 5588 ZINC PLATED
0008	VITE TE 6x16 5739 Z.B.	SCREW HEX HEAD 6x16 5739 ZINC PLATED
0016	VITE AUTOFIL.4,8X16 UNI 6950	SELF-TAPPING SCREW 4,8X16 UNI 6950
0019	BATTERIA 45AH - 54534 (+ Dx)	BATTERY 45AH - 54534 (+ Dx)
0027	VITE TCCE 5x10 5931 Z.B.	SOCKET CAP SCREW 5X10
0047	RONDELLA PIANA 6 - Z.B. 6592	PLAIN WASHER 6-
0050	DADO BLOKM8 DIN 985 Z.B.	SELF-LOCKING NUT M8 DIN 985 ZINC PLATED
0104	DADO BLOKM6 -DIN 985 Z.B.	SELF-LOCKING NUT M6 -DIN 985 ZINC PLATED
0204	CASSETTA PORTA ATTREZZI	TOOL BOX
0337	VITE TE 8x40 5737 Z.B.	SCREW HEX HEAD 8x40 5737 ZINC PLATED
0341	CAVO POSITIVO X DOPPIE L=2000	BATTERY CABLE POSITIVE L=2000
0383	CAVO NEGAT.C/MORS.BAT.27160	NEGATIVE CABLE WITH CLAMP BATTERY 27160
0463	COPERCHIO BATTERIA IN PLASTICA	BATTERY COVER
0464	SCATOLA PORTABATT.OL-90/120 MK8-90/120	BATTERY BOX OL90/120 MK8-90
0468	RONDELLA 6x18X1,5 Z.B.	WASHER 6x18X1,5 ZINC PLATED
0471	VITE TE 6x65 5737 Z.B.	SCREW 6X65
0592	PEDALE ACCELERATORE RIF.30511	ACCELERATOR PEDAL RIF.30511
0593	FILO ACCELERATORE PER PEDALE ***	ACCELERATOR WIRE FOR PEDAL
0598	FARO LED	LED HEADLIGHT
0610	VITE TE 6x40 UNI 5737 Z.B.	SCREW HEX HEAD 6x40 UNI 5737 ZINC P.
0724	RONDELLA 8x24 - ZINCATA BIANCA	WASHER 8x24 - ZINC PLATED
0791	VITE TE 8x45 UNI 5737 Z.B.	SCREW HEX HEAD 8x45 UNI 5737 ZINC PLATED
0968	MORSETTO "+"PER BATTERIA 27150	CLAMP "+" FOR BATTERY 27150
0969	MORSETTO "-" PER BATTERIA 27160	CLAMP "-" FOR BATTERY 27160
10141	TELAIO PROT.MK8-120 CON APERT.	FRAME PROTECTION MK8-120 WITH OPENING
10144	CARTER PROTEZIONE FRIZIONE	CLUTCH GUARD
10175	SEDILE GT75 X HCS EPA SOLO X U.S.A.	SEAT GT75 HCS EPA ONLY U.S.A. MARKET
10179	DISTANZIALE IN ALLUM. 30X30 D.10	ALUMINIUM SPACER 30X30 D10
1246	SEDILE HCS	SEAT FOR HCS
13064	VITE TCCE 8x20 UNI 7984 Z.B.TESTA RIBAS	SCREW TCCE M8X20 UNI 7984 LOWERED HEAD
1342	CARTER PROTEZ.PEDALE ACCEL.	PROTECTION FOR ACCELERATOR PEDAL
1421	STAFFA PORTAFARO DX	RIGHT HEADLIGHT SUPPORT
1422	STAFFA PORTAFARO SX	LEFT HEADLIGHT SUPPORT
1474	GRUPPO ACCELERATORE	ACCELERATOR GROUP
1862	CARTER PROTEZ.POMPA HCS	PUMP PROTECTION GUARD
1931	CARTER PROT.SEDILE MK8-120 HCS	SEAT GUARD FOR MK8-120 HCS
1995	PEDANA AP.PIE.MK8-120HCS	FOOTREST WITH PEDAL MK8-120 HCS



MK8-120 HCS



MK10-120 HCS

**TABLE
TAVOLA B**

- 1657 ENGINE / MOTORE B&S
- 1929 ENGINE / MOTORE HONDA
- 1928 ENGINE / MOTORE KOHLER
- 0711 ENGINE / MOTORE B&S
- 0147 ENGINE / MOTORE HONDA
- 0663 ENGINE / MOTORE KOHLER

- 0465
- 1493

- 1887 ENGINE / MOTORE B&S
- 1918 ENGINE / MOTORE HONDA
- 1970 ENGINE / MOTORE KOHLER

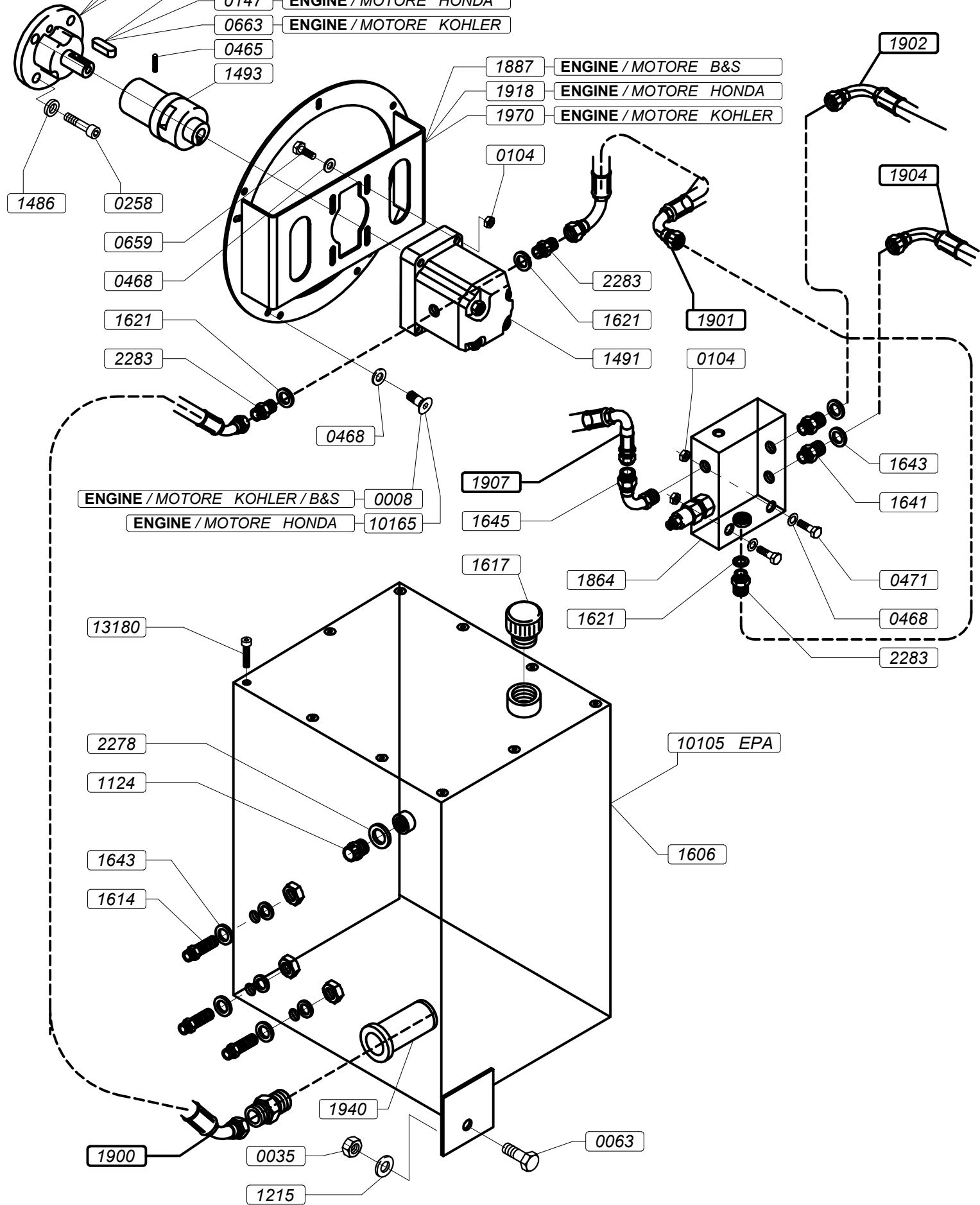

COD.	DESCRIZIONE (I)	DESCRIPTION (GB)
0008	VITE TE 6x16 5739 Z.B.	SCREW HEX HEAD 6x16 5739 ZINC PLATED
0035	DADO BLOKM10 -985 - Z.B.	SELF-LOCKING NUT M10 -985 ZINC PLATED
0063	VITE TE 10x50 -5737 - Z.B.	SCREW TE 10x50 -5737 ZINC PLATED
0104	DADO BLOKM6 -DIN 985 Z.B.	SELF-LOCKING NUT M6 -DIN 985 ZINC PLATED
0147	CHIAVETTA 6X6X15 UNI 6604	KEY 6X6X15 UNI 6604
0258	VITE TCCE 8x16 UNI 5931 Z.B. 12.9	SCREW TCCE 8x16 UNI 5931 G.WHITE
0465	GRANO M6x8 -5927	PIN M6x8 -5927
0468	RONDELLA 6x18X1,5 Z.B.	WASHER 6x18X1,5 ZINC PLATED
0471	VITE TE 6x65 5737 Z.B.	SCREW HEX HEAD 6x65 5737 ZINC PLATED
0659	VITE TE 6x30 5739 Z.B.	SCREW HEX HEAD 6x30 UNI 5739 ZINC PLATED
0663	CHIAVETTA 6x6X25 - 6604A	KEY 6x6X25 - 6604A
0711	CHIAVETTA 6x6x30 - 6604A	KEY 6x6x30 - 6604A
10165	VITE TCCE 4x16 5931 Z.B.	SCREW TCCE 4x16 5931 Z.P.
1124	INDICAT.LIV.OILIO 3/4" VETRO	LEVEL INDICATOR OIL 3/4" GLASS
1215	RONDELLA PIANA 10x30 Z.B.	WASHER 10x30 ZINC PLATED
1486	RONDELLA ZIGRINATA D.8 Z.B.	WASHER D.8 ZINC PLATED
1491	POMPA 1P.23.01.F.BB.A-3,12 cm3	PUMP 1P.23.01.F.BB.A-3,12 cm3
1493	GIUNTI PER HP 0,75-1 GR1-ND5 -33-0012-	COUPLINGS FOR HP 0,75-1 GR1-ND5 -33-0012-
1606	SERBATOIO OLIO C/COPERCHIO HCS	OIL TANK WITH COVER HCS
1614	NIPLES PASSAPARETE GAS M+M 1/4 RIF NP1/4	NIPLES PASSAPARETE GAS M+M 1/4 RIF NP1/4
1617	TAPPO 1" MAN. C/DOPPIO SFIATO	PLUG 1" WITH DOUBLE DRAIN
1621	RONDELLA RAME 17X22X1,5	WASHER COPPER 17X22X1,5
1641	NIPLES 1/4"	NIPLES 1/4"
1643	RONDELLA RAME 13,5X19X1,5 RIF. RR1/4	WASHER COPPER 13,5X19X1,5
1645	RACCORDO A 90 GAS M/M 1/4"	CONNECTION 90 GAS M/M 1/4"
1657	FLANGIA D.85,2-50-19 X B&S 31	FLANGE D.85,2-50-19 X B&S 31
1864	VALVOLA CON DIFFUSORE VLP40	VALVE VLP40
1887	SUPPORTO POMPA	PUMP SUPPORT
1900	TUBO L=1070 SAE 100 R7 D. 3/8" RAC. F.90 + RAC. F.DRITTO 3/8"	PIPE L=1070 SAE 100 R7 D. 3/8" CONN. F.90 + FITTING F. 3/8"
1901	TUBO L=700 SAE 100 R7 D.3/8" RAC. F.90 + RAC. F.90 3/8"	PIPE L=700 SAE 100 R7 D.3/8" CONN. F.90 + FITTING F.90 3/8"
1902	TUBO L=750 SAE 100 R7 D.1/4"	PIPE L=750 SAE 100 R7 D.1/4"
1904	TUBO L=600 SAE 100 R7 D.1/4"	PIPE L=600 SAE 100 R7 D.1/4"
1907	TUBO L=470 SAE 100 R7 D.1/4"	PIPE L=470 SAE 100 R7 D.1/4"
1918	SUPPORTO POMPA	PUMP SUPPORT
1928	FLANGIA PER TRAINO POMPA KOHLER	PUMP SUPPORTING FLANGEKOHLER
1929	FLANGIA PER TRAINO POMPA HONDA	PUMP SUPPORTING FLANGE HONDA
1940	FILTRO OLIO FFIOA 20/6 ATTACCO 1/2	OIL FILTER FFIOA 20/6 FITTING 1/2
1970	SUPPORTO POMPA kohler	PUMP SUPPORT kohler
2278	RONDELLA RAME 3/4" (27x33x1,5)	WASHER COPPER 3/4" (27x33x1,5)
2283	NIPLES M-M 3/8"	NIPLES M-M 3/8"
10105	SERBATOIO OLIO A NORMA CARB-EPA	OIL TANK WITH CARB-EPA
13180	VITE TCCE 6x16 UNI 7984 Z.B.TESTA RIBAS	SCREW 6x16 UNI 7984 ZINC PLATED

COD.	DESCRIZIONE (I)	DESCRIPTION (GB)
0035	DADO BLOKM10 -985 - Z.B.	SELF-LOCKING NUT M10 -985 GALVANIZED WHITE
0041	VITE TE 14X70 UNI5737 Z.B.10.9	SCREW TE 14X70 UNI5737 10.9
0047	RONDELLA PIANA 6 - Z.B. 6592	WASHER 6 - G.W. 6592
0053	DADO M14 BASSO UNI 5589 Z.B.	NUT M14 UNI 5589 GALVANIZED WHITE
0063	VITE TE 10x50 -5737 - Z.B.	SCREW TE 10x50 5737
0084	VITE TE 10x45 UNI 5737 Z.B.	SCREW HEX HEAD 10x45 UNI 5737 GALVANIZED WHITE
0103	VITE TE 10x16 -5739 - Z.B.	SCREW HEX HEAD 10x16 UNI 5739 GALVANIZED W.
0104	DADO BLOKM6 -DIN 985 Z.B.	SELF-LOCKING NUT M6 -DIN 985 GALVANIZED W.
0117	VITE TE 6x10 5739 Z.B.	SCREW HEX HEAD 6x10 UNI 5739 GALVANIZED W.
0121	DADO BLOKM14 BASSO 7474 Z.B	SELF-LOCKING NUT M14 7474 GALVANIZED WHITE
0468	RONDELLA 6x18X1,5 Z.B.	WASHER 6x18X1,5 GALVANIZED WHITE
0471	VITE TE 6x65 5737 Z.B.	SCREW HEX HEAD 6x65 5737 GALVANIZED WHITE
0714	VITE VSP 14x45 - 5933 Z.B.	SCREW C.F.H. 14x45 - 5933 GALVANIZED WHITE
0790	VITE TE 6x20 5739 Z.B.	SCREW HEX HEAD 6x20 UNI 5737 GALVANIZED WHITE
10055	APPOGGIO PER GANCIO SOLLEVAMENTO HCS	BRACKET FOR LIFTING HOOK HCS
1078	RONDELLA ZIGRIN.D10 ZINC.B.	WASHER D10
1614	NIPLES PASSAPARETE GAS M+M 1/4 RIF NP1/4	NIPLES GAS M+M 1/4 RIF NP1/4
1864	VALVOLA CON DIFFUSORE VLP40	VALVE VLP40
1900	TUBO L=1070 SAE 100 R7 D. 3/8" RAC. F.90 + RAC. F.DRITTO 3/8"	PIPE L=1070 SAE 100 R7 D. 3/8" CONN. F.90 + FITTING F. 3/8"
1901	TUBO L=700 SAE 100 R7 D.3/8" RAC. F.90 + RAC. F.90 3/8"	PIPE L=700 SAE 100 R7 D.3/8" CONN. F.90 + FITTING F.90 3/8"
1902	TUBO L=750 SAE 100 R7 D.1/4"	PIPE L=750 SAE 100 R7 D.1/4"
1903	TUBO L=1100 SAE 100 R7 D.1/4"	PIPE L=1100 SAE 100 R7 D.1/4"
1904	TUBO L=600 SAE 100 R7 D.1/4"	PIPE L=600 SAE 100 R7 D.1/4"
1907	TUBO L=470 SAE 100 R7 D.1/4"	PIPE L=470 SAE 100 R7 D.1/4"
1908	TUBO L=640 SAE 100 R7 D.1/4"	PIPE L=640 SAE 100 R7 D.1/4"
1909	TUBO L=680 SAE 100 R7 D.1/4"	PIPE L=680 SAE 100 R7 D.1/4"
1910	TUBO L=620 SAE 100 R7 D.1/4"	PIPE L=620 SAE 100 R7 D.1/4"
1911	CARTER X JOYSTIK-TELECOM.	CARTER FOR JOYSTIK
1912	COPERCHIO X CARTER JOYSTICK ZINC MONSTER	COVER FOR CARTER JOYSTIK GALVANIZED
1215	RONDELLA PIANA 10x30 Z.B.	WASHER 10x30 GALVANIZED WHITE
1350	CILINDRO AL.50-ST.30-CORSA 23 BOR.1/4"	CYLINDER AL.50-ST.30-STROKE 23 ATT.1/4"
1488	TELECOMANDO SX C/BOTTONE ACQUA	LH REMOTE CONTROL WITH WATER BOTTON
1489	JOYSTICK DX HPCJ0G21KSS2300000	RH JOYSTICK HPCJ0G21KSS2300000
1621	RONDELLA RAME 17X22X1,5	WASHER COPPER 17X22X1,5
1635	TERMIN.SNODO MARCA "SB" JAM 14	TERMIN.ARTICULATION "SB" JAM 14
1636	TERMIN.SNODO MARCA "SB" JAF 14	TERMIN.ARTICULATION "SB" JAF 14
1641	NIPLES 1/4"	NIPLES 1/4"

COD.	DESCRIZIONE (I)	DESCRIPTION (GB)
1643	RONDELLA RAME 13,5X19X1,5	WASHER COPPER 13,5X19X1,5
1645	RACCORDO A 90 GAS M/M 1/4"	CONNECTION 90 GAS M/M 1/4"
1646	BULLONE FORATO GAS 1/4" CH.19	PERFORATED BOLT GAS 1/4" CH.19
1648	VITE TE 10X75 5739 Z.B. TUT.FI	SCREW HEX HEAD 10X75 5739 G.W.
1721	DISTANZIALE D.21,3-14,9 L=23	SPACER D.21,3-14,9 L=23
1799	VITE TE 14X55 UNI 5737 Z.B.	SCREW HEX HEAD 14X55 UNI 5737 G.W.
1926	SUPPORTO CILINDRI CENTRALE Z.B	CENTRAL CYLINDER SUPPORT G.W.
1927	SUPPORTO CILINDRO POSTERIORE	REAR SUPPORT CYLINDER
2283	NIPLES M-M 3/8"	NIPLES M-M 3/8"

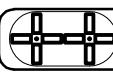

 **MK8-120 HCS**

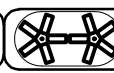
 **MK10-120 HCS**

**TABLE
TAVOLA** **D**

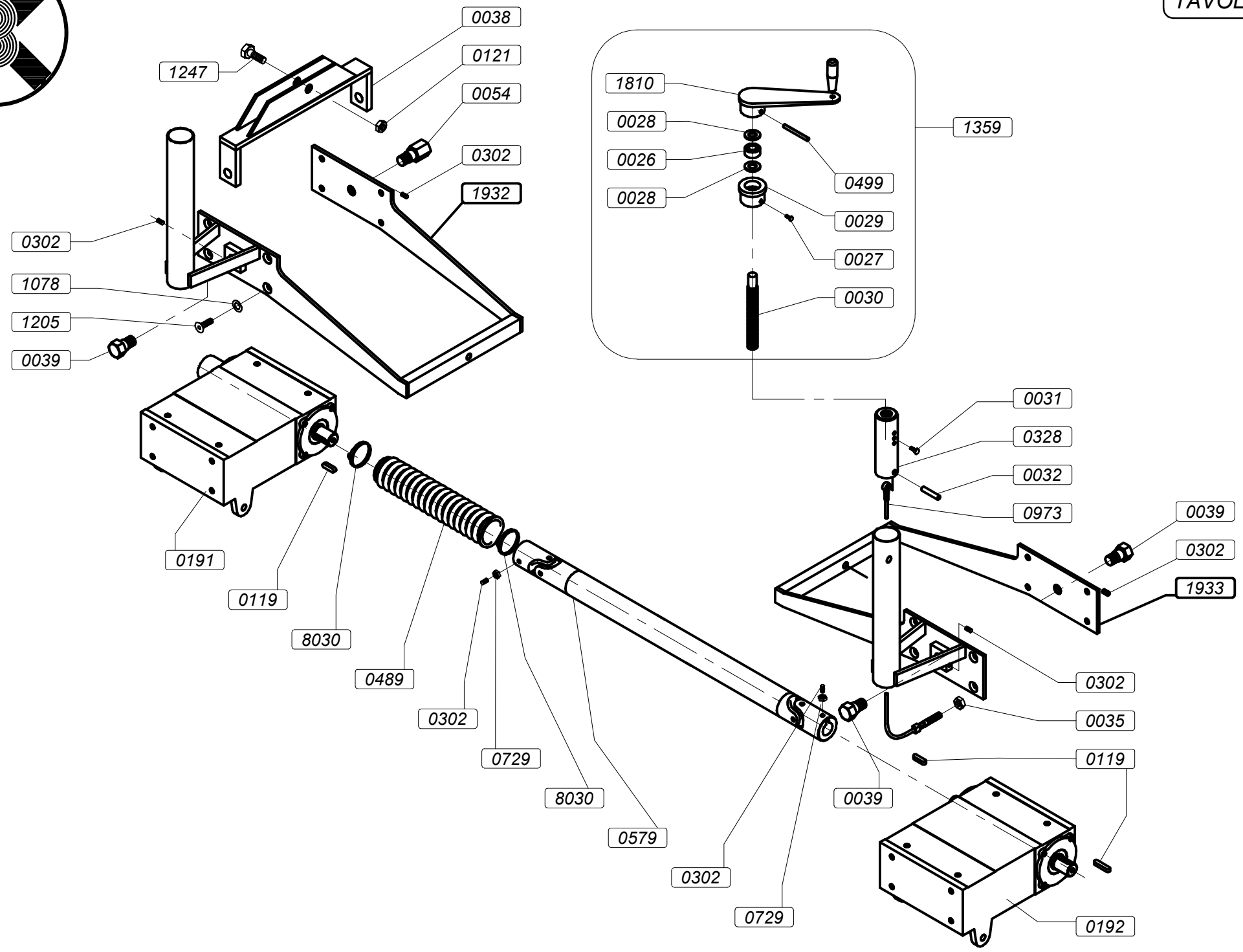

COD.	DESCRIZIONE (I)	DESCRIPTION (GB)
0026	CUSCINETTO REGGISPINTA AXK1528	BEARING THRUST AXK1528
0027	VITE TCCE 5x10 5931 Z.B.	SCREW TCCE 5x10 5931 ZINC PLATED
0028	RALLA AS 1528	BOLSTER AS 1528
0029	ANELLO PORTACUSC.REGGISPINTA	RING BEARING THRUST
0030	PERNO FILETTATO x REGIST. PALE	PIN THREAD FOR REGIS. TOOLHOLDER
0031	VITE TCCE 6x10 5931 Z.B.	SCREW TCCE 6x10 5931 ZINC PLATED
0032	SPINA CILINDRICA 8x40 UNI 1707	UNIVERSAL PIN 8x40 UNI 1707
0035	DADO BLOKM10 -985 - Z.B.	SELF-LOCKING NUT M10 -985 ZINC PLATED
0038	PONTE BASCULANTE	SWINGING SUPPORT
0039	PERNO BASCULANTE M18 L=45 CH27Z.B.	PIN M18 L=45 CH27Z.B.
0054	VITE BLOCCAGGIO M18-14 L=60 CH27ZB	LOCK SCREW M18-14 L=60 CH27ZB
0119	CHIAVETTA 8x7x30 - 6604A	KEY 8x7x30 - 6604A
0121	DADO BLOKM14 BASSO 7474 Z.B	SELF-LOCKING NUT M14 7474 ZINC PLATED
0191	RIDUTTORE COMPLETO DX V100	RH GEAR BOX V100
0192	RIDUTTORE COMPLETO SX V100	LH GEAR BOX V100
0302	GRANO M6x16 - 5927	DOWEL M6x16 - 5927
0328	ATTACCO SUPERIORE x CAVO DI REGISTRO	SUP.ATTACHMENT FOR REGISTER CABLE
0489	CUFFIA PROTEZIONE CARDANO	DUST BOOT GIMBAL
0499	SPINA ELASTICA 6x30	UNIVERSAL PIN 6x30
0578	BASCULANTE SX OL120/MK8-90/120	GUIDE UNIT LH FLANGE OL120/MK890/120
0579	ALBERO CARD. OL120/MK8-90-120	DRIVE SHAFT OL120/MK8-90-120
0580	BASCULANTE DX OL120/MK8-90-120	GUIDE UNIT RH FLANGE
0729	DADO M6 5589 BASSO Z.B.	LOW NUT M6 5589
0973	CAVO D.4X49X535 C/TERM.	CABLE D.4X49X535
1078	RONDELLA ZIGRIN.D10 ZINC.B.	WASHER D10 ZINC PLATED
1205	VITE TE 10x20 UNI 5739 Z.B.	SCREW TE 10x20 UNI 5739 ZINC PLATED
1247	VITE TE 14X75 UNI5737 Z.B.	SCREW TE 14X75 UNI5737 ZINC PLATED
1359	COMPLESSIVO SOLLEVAMENTO PALE	BLADE LIFTER UNIT W/CRANK
1810	LEVA ZINC. CON MANIGLIA NERA M8	LEVER WITH BLACK KNOB M8
8030	FASCETTA	HOSE CLAMP BLACK B4-190C 4,8X200



MK8-120 HCS

TABLE
TAVOLA **E1**

RIGHT ROTOR
ROTORE DESTRO

BATTERY SIDE
LATO BATTERIA

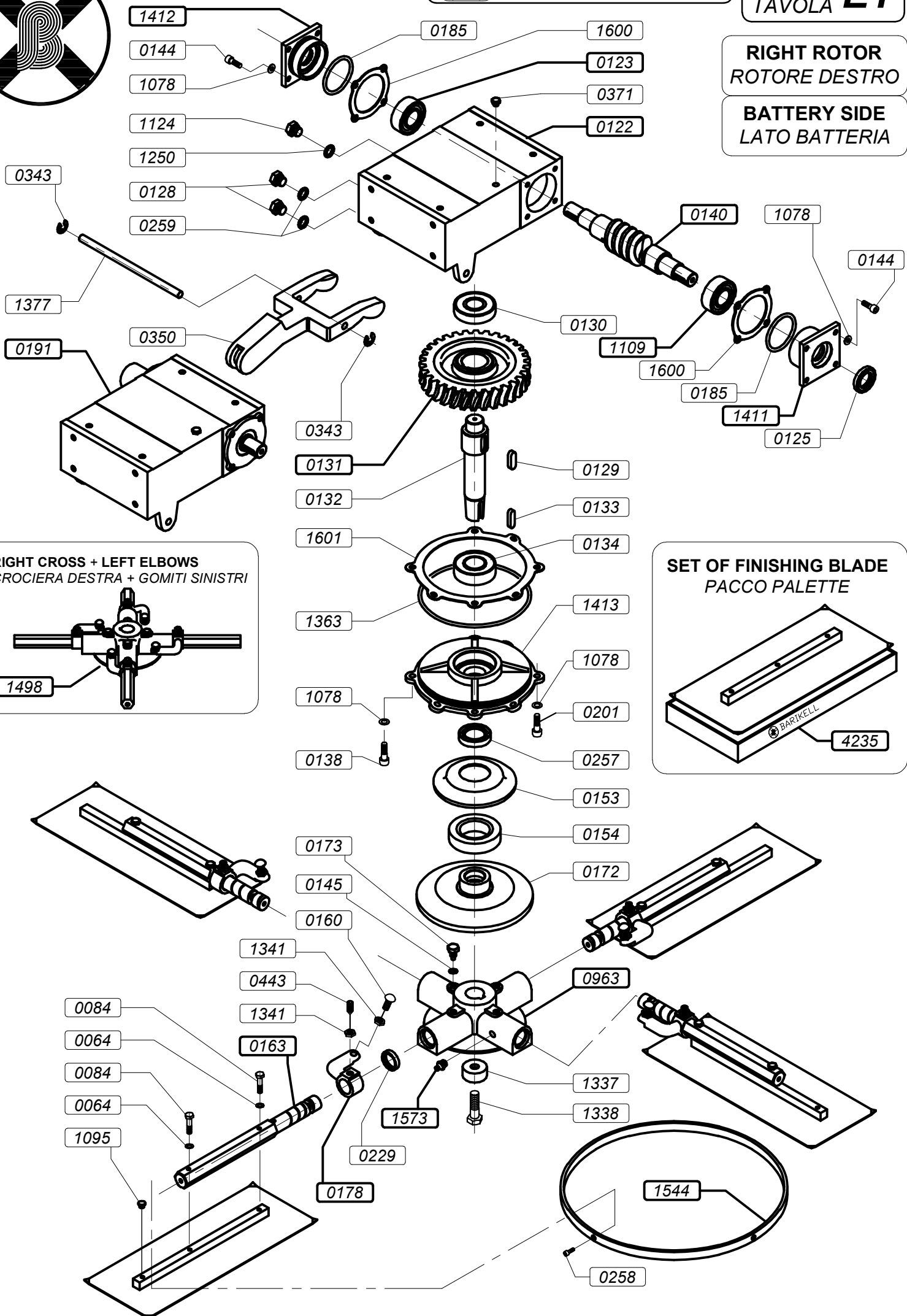

RIGHT CROSS + LEFT ELBOWS
CROCIERA DESTRA + GOMITI SINISTRI

1498

SET OF FINISHING BLADE
PACCO PALETTE

4235

COD.	DESCRIZIONE (I)	DESCRIPTION (GB)
0064	RONDELLA GROWER 10 - Z.B.	WASHER 10 ZINC PLATED
0084	VITE TE 10x45 UNI 5737 Z.B.	SCREW HEX HEAD 10x45 UNI 5737 ZINC PLATED
0122	SCATOLA DX RIDUTTORE V100	RH GEAR BOX V100
0123	CUSCINETTO CONICO 30206 V100 CX	TAPER BEARING 30206 V100 CX
0125	PARAOLIO DOPPIA TENUTA 30X47X7	OILSEAL DOUBLE SEALING 30X47X7
0128	TAPPO SCARICO OLIO 3/8" GAS ZB	PLUG OIL 3/8" GAS ZINC PLATED
0129	CHIAVETTA12x8x35 - 6604A	KEY 12x8x35 - 6604A
0130	CUSCINETTO CONICO 30306 CX	TAPER BEARING 30306 CX
0131	CORONA DENTATA DX V100	RH CROWN GEAR V100
0132	ALBERO LENTO V100	SHAFT V100
0133	CHIAVETTA10x8x35 - 6604A	KEY 10x8x35 - 6604A
0134	CUSCINETTO CONICO 32207 V100 CX	TAPER BEARING 32207 V100 CX
0138	VITE TCCE 10x20 Z.B. UNI 5931	SCREW TCCE 10x20 G.W. UNI 5931
0140	VITE SENZA FINE DX V100	RH WORM SCREW V100
0144	VITE TE 10x25 5739 Z.B.	SCREW HEX HEAD 10x25 5739 ZINC PLATED
0145	RONDELLA PIANA 10x21 6592 Z.B.	WASHER 10x21 6592 ZINC PLATED
0153	COPRICUSCINETTO 4-90/4-120	COVER BEARING 4-90/4-120
0154	CUSCINETTO REGGISPINTA BCA2256	BEARING BCA2256
0160	VITE TTDE10X30 UNI 5731 SENZA	SCREW TTDE10X30 UNI 5731
0163	BRACCIO P.PALE MK8-120	BEND FOR TOOL HOLDER MK8-120
0172	CAMPANA REGIS.PALE 4-120/OL90	UPPER HEAD TOOL HOLDER 4-120/OL90
0173	VITE BLOC.BRAC.P.PALE 4-90/120	SCREW FIX TOOLHOLDER 4-90/120
0178	GOMITO SX GHISA D.28	LH BEND CAST IRON D.28
0185	OR 3262 NBR PER V100	OR 3262 NBR PER V100
0191	RIDUTTORE COMPLETO DX V100	RH COMPLETE GEAR BOX V100
0201	VITE VSP 10x20 5933 Z.B.	SCREW VSP 10x20 5933 ZINC PLATED
0229	O-RING D.28 SEZ.1,5	O-RING D.28 SEZ.1,5
0257	PARAOLIO DOP.TENUTA 35X55X10	OIL SEAL 35X55X10
0258	VITE TCCE 8x16 UNI 5931 Z.B. 12.9	SOCKET CAP SCREW 8X16 5931
0259	RONDELLA ALL. 17x23x1.5 X RID.	WASHER ALL. 17x23x1.5
0343	ANELLO RADIALE DIAM.10	SEAL DIAM.10
0350	FORCELLA COMANDO PALE D.11	YOKE CONTROL TOOLHOLDER D.11
0371	TAPPO SFIATO 1/8"+ RONDELLA IN RAME	BREATHER PLUG 1/8"+ COPPER WASHER
0443	GRANO M10x20 UNI 5927	DOWEL M10x20 UNI 5927
0963	CROCERA D.28 OL120/MK8-120/MK8-90	SPIDER D.28 OL120/MK8-120/MK8-90
1078	RONDELLA ZIGRIN.D10 ZINC.B.	WASHER D10 ZINC PLATED
1095	TAPPO POLIETILENE NEUTRO D.9mm	PLUG POLYETHYLENE D.9 mm
1109	CUSCI.CONICO 30206 "NSK" V100	COVER BEARING 30206 "NSK" V100
1124	INDICAT.LIV.OLIO 3/4" VETRO	LEVEL INDICATOR OIL 3/4" GLASS
1250	RONDELLA ALL.27X33X1,5 3/4"	WASHER ALL.27X33X1,5 3/4"
1337	RONDELLA BLOCC. CROCERA X DOPP	WASHER FOR LOCK SPIDER
1338	VITE TE 12x1.5x35 UNI5740 10.9 z.b.	SCREW HEX HEAD 12x1.5x35 UNI5740 ZINC PLATED
1341	DADO M10 5589 BASSO GREZZO	NUT M10 5589
1363	OR 4725 183,75X3,53 SH70 NBR	OR 4725 183,75X3,53 SH70 NBR
1377	PERNO FORCEL.D.11 L=219 V100	PIN FOR YOKE D.11 L=219 V100
1411	COPERCHIO LATERALE APERTO V100	LATERAL OPENED COVER V100

COD.	DESCRIZIONE (I)	DESCRIPTION (GB)
1412	COPERCHIO LAT.CHIUSO V100	LATERAL CLOSED COVER V100
1413	COPERCHIO INF. V100	INFERIOR COVER V100
1498	CROCIERA COMPL.DX MK8-120 C/INGR	SPIDER RIGHT MK8-120
1544	CERCHIO STABILIZZATORE MK8-120 4-80	STABILISER RING MK8-120
1573	INGRASSATORE M8X1.25 2802	GREASE FITTING M8X1.25 2802
1600	GUARNIZIONE LATERALE V100	LATERAL SEAL V100
1601	GUARNIZIONE INFERIORE V100	INFERIOR SEAL V100
4235	PACCO PALETTE MK8-120	SET OF FINISHING BLADES MK8-120



MK10-120 HCS

TABLE
TAVOLA **E2**

RIGHT ROTOR
ROTORE DESTRO

BATTERY SIDE
LATO BATTERIA

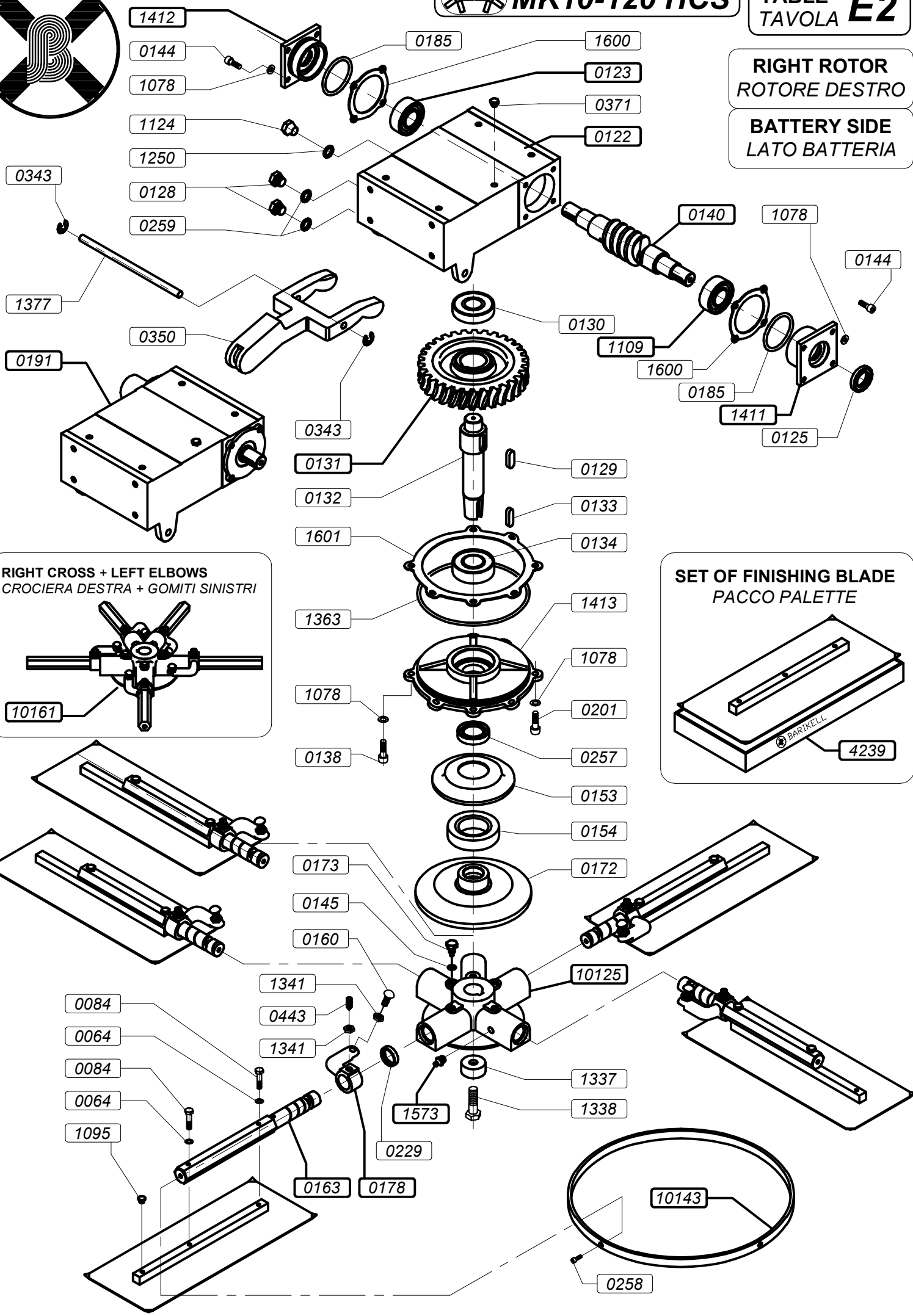

RIGHT CROSS + LEFT ELBOWS
CROCIERA DESTRA + GOMITI SINISTRI

10161

SET OF FINISHING BLADE
PACCO PALETTE

4239

COD.	DESCRIZIONE (I)	DESCRIPTION (GB)
0064	RONDELLA GROWER 10 - Z.B.	WASHER 10 ZINC PLATED
0084	VITE TE 10x45 UNI 5737 Z.B.	SCREW HEX HEAD 10x45 UNI 5737 ZINC PLATED
0122	SCATOLA DX RIDUTTORE V100	RH GEAR BOX V100
0123	CUSCINETTO CONICO 30206 V100 CX	TAPER BEARING 30206 V100 CX
0125	PARAOLIO DOPPIA TENUTA 30X47X7	OILSEAL DOUBLE SEALING 30X47X7
0128	TAPPO SCARICO OLIO 3/8" GAS ZB	PLUG OIL 3/8" GAS ZINC PLATED
0129	CHIAVETTA12x8x35 - 6604A	KEY 12x8x35 - 6604A
0130	CUSCINETTO CONICO 30306 CX	TAPER BEARING 30306 CX
0131	CORONA DENTATA DX V100	RH CROWN GEAR V100
0132	ALBERO LENTO V100	SHAFT V100
0133	CHIAVETTA10x8x35 - 6604A	KEY 10x8x35 - 6604A
0134	CUSCINETTO CONICO 32207 V100 CX	TAPER BEARING 32207 V100 CX
0138	VITE TCCE 10x20 Z.B. UNI 5931	SCREW TCCE 10x20 G.W. UNI 5931
0140	VITE SENZA FINE DX V100	RH WORM SCREW V100
0144	VITE TE 10x25 5739 Z.B.	SCREW HEX HEAD 10x25 5739 ZINC PLATED
0145	RONDELLA PIANA 10x21 6592 Z.B.	WASHER 10x21 6592 ZINC PLATED
0153	COPRICUSCINETTO 4-90/4-120	COVER BEARING 4-90/4-120
0154	CUSCINETTO REGGISPINTA BCA2256	BEARING BCA2256
0160	VITE TTDE10X30 UNI 5731 SENZA	SCREW TTDE10X30 UNI 5731
0163	BRACCIO P.PALE MK8-120	BEND FOR TOOL HOLDER MK8-120
0172	CAMPANA REGIS.PALE 4-120/OL90	UPPER HEAD TOOL HOLDER 4-120/OL90
0173	VITE BLOC.BRAC.P.PALE 4-90/120	SCREW FIX TOOLHOLDER 4-90/120
0178	GOMITO SX GHISA D.28	LH BEND CART IRON D.28
0185	OR 3262 NBR PER V100	OR 3262 NBR PER V100
0191	RIDUTTORE COMPLETO DX V100	RH COMPLETE GEAR BOX V100
0201	VITE VSP 10x20 5933 Z.B.	SCREW VSP 10x20 5933 ZINC PLATED
0229	O-RING D.28 SEZ.1,5	O-RING D.28 SEZ.1,5
0257	PARAOLIO DOP.TENUTA 35X55X10	OIL SEAL 35X55X10
0258	VITE TCCE 8x16 UNI 5931 Z.B. 12.9	SOCKET CAP SCREW 8X16 5931
0259	RONDELLA ALL. 17x23x1.5 X RID.	WASHER ALL. 17x23x1.5
0343	ANELLO RADIALE DIAM.10	SEAL DIAM.10
0350	FORCELLA COMANDO PALE D.11	YOKE CONTROL TOOLHOLDER D.11
0371	TAPPO SFIATO 1/8"+ RONDELLA IN RAME	BREATHER PLUG 1/8"+ COPPER WASHER
0443	GRANO M10x20 UNI 5927	DOWEL M10x20 UNI 5927
10125	CROCERA MK10-120	SPIDER MK10-120
10143	CERCHIO STABILIZZATORE MK10-120	STABILISER RING MK10-120
10161	CROCIERA COMPL.DX MK10-120 C/INGR	SPIDER RIGHT MK10-120
1078	RONDELLA ZIGRIN.D10 ZINC.B.	WASHER D10 ZINC PLATED
1095	TAPPO POLIETILENE NEUTRO D.9mm	PLUG POLYETHYLENE D.9mm
1109	CUSCI.CONICO 30206 "NSK" V100	COVER BEARING 30206 "NSK" V100
1124	INDICAT.LIV.OLIO 3/4" VETRO	LEVEL INDICATOR OIL 3/4" GLASS
1250	RONDELLA ALL.27X33X1,5 3/4"	WASHER ALL.27X33X1,5 3/4"
1337	RONDELLA BLOCC. CROCERA X DOPP	WASHER FOR LOCK SPIDER
1338	VITE TE 12x1.5x35 UNI5740 10.9 z.b.	SCREW HEX HEAD 12x1.5x35 UNI5740 ZINC PLATED
1341	DADO M10 5589 BASSO GREZZO	NUT M10 5589
1363	OR 4725 183,75X3,53 SH70 NBR	OR 4725 183,75X3,53 SH70 NBR

COD.	DESCRIZIONE (I)	DESCRIPTION (GB)
1377	PERNO FORCEL.D.11 L=219 V100	PIN FOR YOKE D.11 L=219 V100
1411	COPERCHIO LATERALE APERTO V100	LATERAL OPENED COVER V100
1412	COPERCHIO LAT.CHIUSO V100	LATERAL CLOSED COVER V100
1413	COPERCHIO INF. V100	INFERIOR COVER V100
1573	INGRASSATORE M8X1.25 2802	GREASE FITTING M8X1.25 2802
1600	GUARNIZIONE LATERALE V100	LATERAL SEAL V100
1601	GUARNIZIONE INFERIORE V100	INFERIOR SEAL V100
4239	PACCO PALETTE MK10-120	SET OF FINISHING BLADES MK10-120

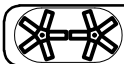

MK8-120 HCS

TABLE F1
TAVOLA **F1**

LEFT ROTOR
ROTORE SINISTRO

ENGINE SIDE
LATO MOTORE

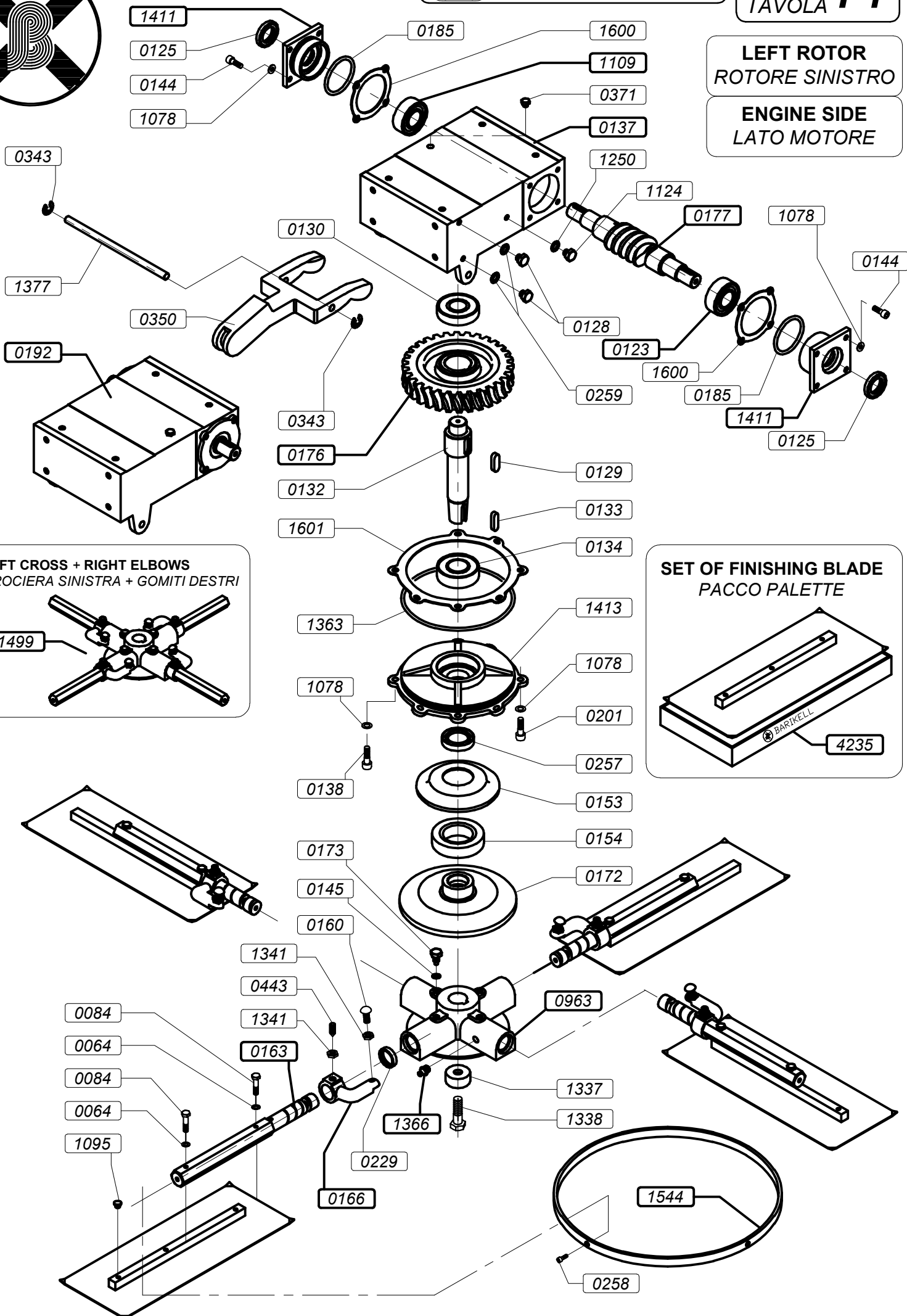

LEFT CROSS + RIGHT ELBOWS
CROCIERA SINISTRA + GOMITI DESTRI

1499

SET OF FINISHING BLADE
PACCO PALETTE

4235

BARTKELL

1544

0258

COD.	DESCRIZIONE (I)	DESCRIPTION (GB)
0064	RONDELLA GROWER 10 - Z.B.	WASHER 10 ZINC PLATED
0084	VITE TE 10x45 UNI 5737 Z.B.	SCREW HEX HEAD 10x45 UNI 5737 ZINC PLATED
0123	CUSCINETTO CONICO 30206 V100 CX	TAPER BEARING 30206 V100 CX
0125	PARAOLIO DOPPIA TENUTA 30X47X7	OILSEAL DOUBLE SEALING 30X47X7
0128	TAPPO SCARICO OLIO 3/8" GAS ZB	PLUG OIL 3/8" GAS ZINC PLATED
0129	CHIAVETTA12x8x35 - 6604A	KEY 12x8x35 - 6604A
0130	CUSCINETTO CONICO 30306 CX	TAPER BEARING 30306 CX
0132	ALBERO LENTO V100	SHAFT V100
0133	CHIAVETTA10x8x35 - 6604A	KEY 10x8x35 - 6604A
0134	CUSCINETTO CONICO 32207 V100 CX	TAPER BEARING 32207 V100 CX
0137	SCATOLA SX RIDUTTORE V100	LEFT GEARBOX V100
0138	VITE TCCE 10x20 Z.B. UNI 5931	SCREW TCCE 10x20 ZINC PLATED UNI 5931
0144	VITE TE 10x25 5739 Z.B.	SCREW HEX HEAD 10x25 5739 ZINC PLATED
0145	RONDELLA PIANA 10x21 6592 Z.B.	WASHER 10x21 6592 ZINC PLATED
0153	COPRICUSCINETTO 4-90/4-120	COVER BEARING 4-90/4-120
0154	CUSCINETTO REGGISPINTA BCA2256	BEARING BCA2256
0160	VITE TTDE10X30 UNI 5731 SENZA	SCREW TTDE10X30 UNI 5731
0163	BRACCIO P.PALE MK8-120	BEND FOR TOOL HOLDER MK8-120
0166	GOMITO DX GHISA D28	RH ELBOW D28 MK8-90/120/OL120
0172	CAMPANA REGIS.PALE 4-120/OL90	UPPER HEAD TOOL HOLDER 4-120/OL90
0173	VITE BLOC.BRAC.P.PALE 4-90/120	SCREW FIX TOOLHOLDER 4-90/120
0176	CORONA DENTATA SX V100	LH CROWN GEAR V100
0177	VITE SENZA FINE SX V100	LH WORMSCREW V100
0185	OR 3262 NBR PER V100	OR 3262 NBR PER V100
0192	RIDUTTORE COMPLETO SX V100	LH GEAR BOX V100
0201	VITE VSP 10x20 5933 Z.B.	SCREW VSP 10x20 5933 ZINC PLATED
0229	OR D.28 SEZ.1,5 PER CROC.	O-RING D.28 SEZ.1,5
0257	PARAOLIO DOP.TENUTA 35X55X10	OIL SEAL 35X55X10
0258	VITE TCCE 8x16 UNI 5931 Z.B. 12.9	SOCKET CAP SCREW 8X16 5931
0259	RONDELLA ALL. 17x23x1.5 X RID.	WASHER ALL. 17x23x1.5
0343	ANELLO RADIALE DIAM.10	SEAL DIAM.10
0350	FORCELLA COMANDO PALE D.11	YOKE CONTROL TOOLHOLDER D.11
0371	TAPPO SFIATO 1/8"+ RONDELLA IN RAME	BREATHER PLUG 1/8"+ COPPER WASHER
0443	GRANO M10x20 UNI 5927	DOWEL M10x20 UNI 5927
0963	CROCERA D.28 OL120/MK8-120/MK8-90	SPIDER D.28 OL120/MK8-120/MK8-90
1078	RONDELLA ZIGRIN.D10 ZINC.B.	WASHER D10 ZINC PLATED
1095	TAPPO POLIETILENE NEUTRO D.9mm	PLUG POLYETHYLENE D.9mm
1109	CUSCI.CONICO 30206 "NSK" V100	COVER BEARING 30206 "NSK" V100
1124	INDICAT.LIV.OLIO 3/4" VETRO	LEVEL INDICATOR OIL 3/4" GLASS
1250	RONDELLA ALL.27X33X1,5 3/4"	WASHER ALL.27X33X1,5 3/4"
1337	RONDELLA BLOCC. CROCERA X DOPP	WASHER FOR LOCK SPIDER
1338	VITE TE 12x1.5x35 UNI5740 10.9 z.b.	SCREW HEX HEAD 12x1.5x35 UNI5740 ZINC PLATED
1341	DADO M10 5589 BASSO GREZZO	NUT M10 5589
1363	OR 4725 183,75X3,53 SH70 NBR	OR 4725 183,75X3,53 SH70 NBR
1366	INGRASSATORE M8X1,25	GREASE FITTING M8X1,25
1377	PERNO FORCEL.D.11 L=219 V100	PIN FOR YOKE D.11 L=219 V100
1411	COPERCHIO LATERALE APERTO V100	SIDE COVER V100
1413	COPERCHIO INF. V100	INFERIOR COVER V100
1499	CROCIERA COMPL.SX MK8-120 C/INGR	SPIDER LEFT MK8-120
1544	CERCHIO STABILIZZATORE MK8-120 4-80	STABILISER RING MK8-120
1600	GUARNIZIONE LATERALE V100	LATERAL SEAL V100
1601	GUARNIZIONE INFERIORE V100	INFERIOR SEAL V100
4235	PACCO PALETTE MK8-120	SET OF FINISHING BLADES MK8-120



MK10-120 HCS

TABLE
TAVOLA **F2**

LEFT ROTOR
ROTORE SINISTRO

ENGINE SIDE
LATO MOTORE

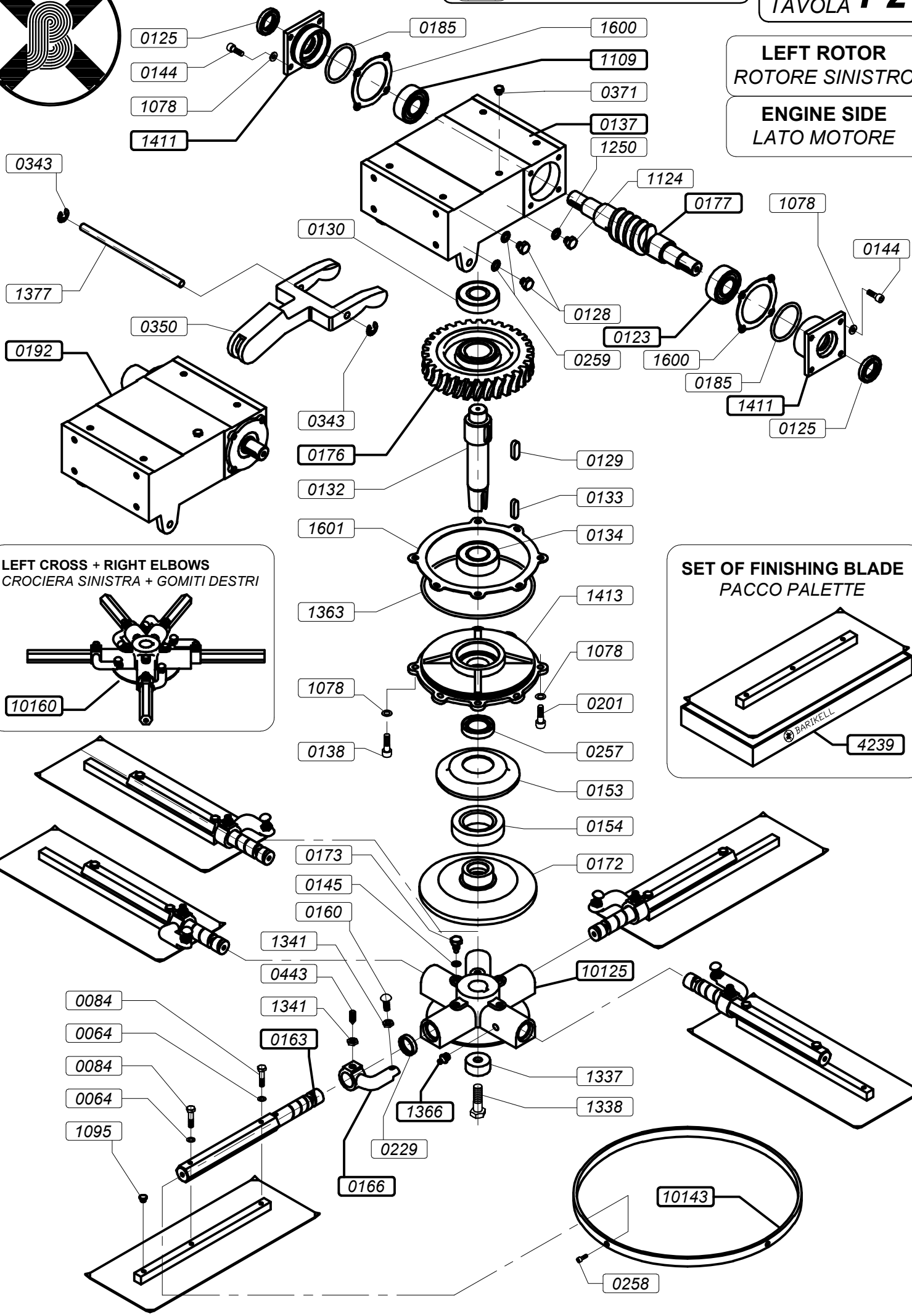

LEFT CROSS + RIGHT ELBOWS
CROCIERA SINISTRA + GOMITI DESTRI

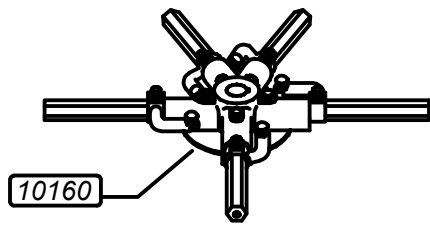

SET OF FINISHING BLADE
PACCO PALETTE

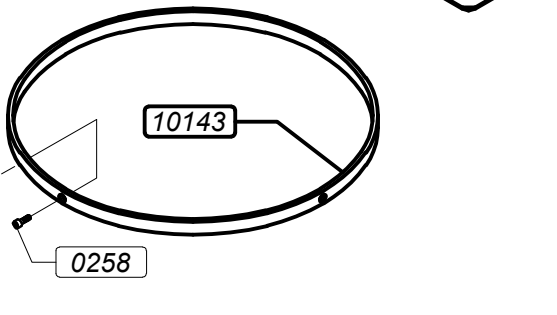
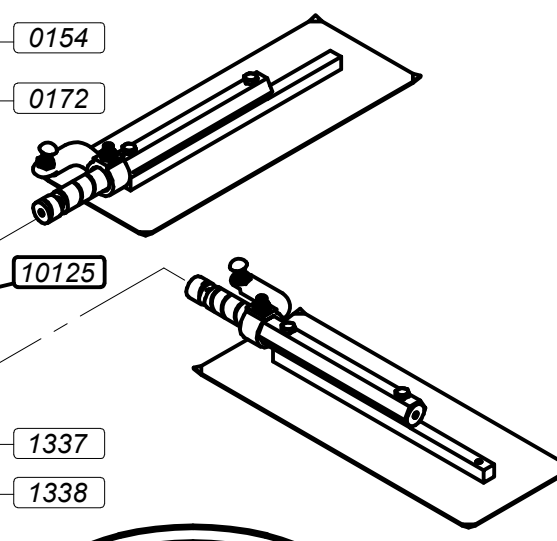
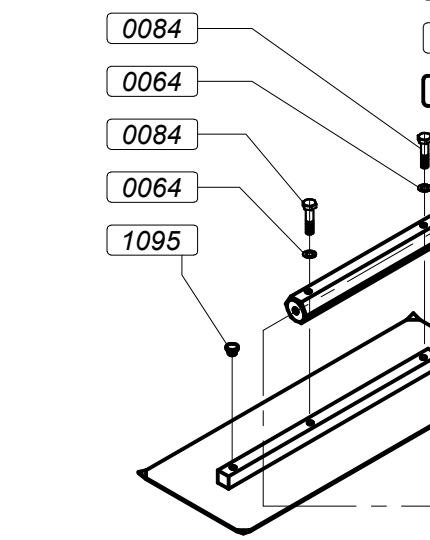
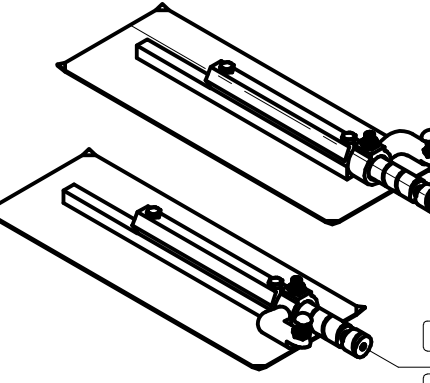
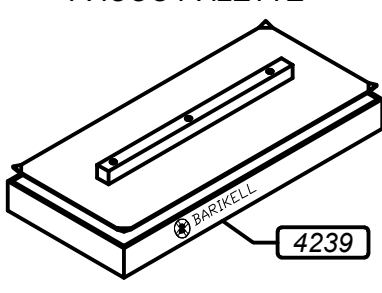

COD.	DESCRIZIONE (I)	DESCRIPTION (GB)
0064	RONDELLA GROWER 10 - Z.B.	WASHER 10 ZINC PLATED
0084	VITE TE 10x45 UNI 5737 Z.B.	SCREW HEX HEAD 10x45 UNI 5737 ZINC PLATED
0123	CUSCINETTO CONICO 30206 V100 CX	TAPER BEARING 30206 V100 CX
0125	PARAOLIO DOPPIA TENUTA 30X47X7	OILSEAL DOUBLE SEALING 30X47X7
0128	TAPPO SCARICO OLIO 3/8" GAS ZB	PLUG OIL 3/8" GAS ZINC PLATED
0129	CHIAVETTA12x8x35 - 6604A	KEY 12x8x35 - 6604A
0130	CUSCINETTO CONICO 30306 CX	TAPER BEARING 30306 CX
0132	ALBERO LENTO V100	SHAFT V100
0133	CHIAVETTA10x8x35 - 6604A	KEY 10x8x35 - 6604A
0134	CUSCINETTO CONICO 32207 V100 CX	TAPER BEARING 32207 V100 CX
0137	SCATOLA SX RIDUTTORE V100	LH GEAR BOX V100
0138	VITE TCCE 10x20 Z.B. UNI 5931	SCREW TCCE 10x20 G.W. UNI 5931
0144	VITE TE 10x25 5739 Z.B.	SCREW HEX HEAD 10x25 5739 ZINC PLATED
0145	RONDELLA PIANA 10x21 6592 Z.B.	WASHER 10x21 6592 ZINC PLATED
0153	COPRICUSCINETTO 4-90/4-120	COVER BEARING 4-90/4-120
0154	CUSCINETTO REGGISPINTA BCA2256	BEARING BCA2256
0160	VITE TTDE10X30 UNI 5731 SENZA	SCREW TTDE10X30 UNI 5731
0163	BRACCIO P.PALE MK8-120	BEND FOR TOOL HOLDER MK8-120
0166	GOMITO DX GHISA D.28	RH BEND CART IRON D.28
0172	CAMPANA REGIS.PALE 4-120/OL90	UPPER HEAD TOOL HOLDER 4-120/OL90
0173	VITE BLOC.BRAC.P.PALE 4-90/120	SCREW FIX TOOLHOLDER 4-90/120
0176	CORONA DENTATA SX V100	LH CROWN GEAR V100
0177	VITE SENZA FINE SX V100	LH WORM SCREW V100
0185	OR 3262 NBR PER V100	OR 3262 NBR PER V100
0192	RIDUTTORE COMPLETO SX V100	LH COMPLETE GEAR BOX V100
0201	VITE VSP 10x20 5933 Z.B.	SCREW VSP 10x20 5933 ZINC PLATED
0229	O-RING D.28 SEZ.1,5	O-RING D.28 SEZ.1,5
0257	PARAOLIO DOP.TENUTA 35X55X10	OIL SEAL 35X55X10
0258	VITE TCCE 8x16 UNI 5931 Z.B. 12.9	SOCKET CAP SCREW 8X16 5931
0259	RONDELLA ALL. 17x23x1.5 X RID.	WASHER ALL. 17x23x1.5
0343	ANELLO RADIALE DIAM.10	SEAL DIAM.10
0350	FORCELLA COMANDO PALE D.11	YOKE CONTROL TOOLHOLDER D.11
0371	TAPPO SFIATO 1/8"+ RONDELLA IN RAME	BREATHER PLUG 1/8"+ COPPER WASHER
0443	GRANO M10x20 UNI 5927	DOWEL M10x20 UNI 5927
10125	CROCERA MK10-120	SPIDER MK10-120
10143	CERCHIO STABILIZZATORE MK10-120	STABILISER RING MK10-120
10160	CROCIERA COMPL.SX MK10-120 C/INGR	SPIDER LEFT MK10-120
1078	RONDELLA ZIGRIN.D10 ZINC.B.	WASHER D10 ZINC PLATED
1095	TAPPO POLIETILENE NEUTRO D.9mm	PLUG POLYETHYLENE D.9mm
1109	CUSCI.CONICO 30206 "NSK" V100	COVER BEARING 30206 "NSK" V100
1124	INDICAT.LIV.OLIO 3/4" VETRO	LEVEL INDICATOR OIL 3/4" GLASS
1250	RONDELLA ALL.27X33X1,5 3/4"	WASHER ALL.27X33X1,5 3/4"
1337	RONDELLA BLOCC. CROCERA X DOPP	WASHER FOR LOCK SPIDER
1338	VITE TE 12x1.5x35 UNI5740 10.9 z.b.	SCREW HEX HEAD 12x1.5x35 UNI5740 ZINC PLATED
1341	DADO M10 5589 BASSO GREZZO	NUT M10 5589
1363	OR 4725 183,75X3,53 SH70 NBR	OR 4725 183,75X3,53 SH70 NBR

COD.	DESCRIZIONE (I)	DESCRIPTION (GB)
1377	PERNO FORCEL.D.11 L=219 V100	PIN FOR YOKE D.11 L=219 V100
1411	COPERCHIO LATERALE APERTO V100	LATERAL OPENED COVER V100
1413	COPERCHIO INF. V100	INFERIOR COVER V100
1366	INGRASSATORE M8X1,25	GREASER M8X1,25
1600	GUARNIZIONE LATERALE V100	LATERAL SEAL V100
1601	GUARNIZIONE INFERIORE V100	INFERIOR SEAL V100
4239	PACCO PALETTE MK10-120	SET OF FINISHING BLADES MK10-120

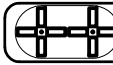

WATER AND FUEL SYSTEM
IMPIANTO ACQUA E BENZINA

 **MK8-120 HCS**

 **MK10-120 HCS**

TABLE
TAVOLA **G1**



COD.	DESCRIZIONE (I)	DESCRIPTION (GB)
0063	VITE TE 10x50 -5737 - Z.B.	HEXAGONAL SCREW 10X50 5737
0104	DADO BLOKM6 -DIN 985 Z.B.	BLOK NUT M6 985
0468	RONDELLA 6x18X1,5 Z.B.	WASHER 6x18X1,5
0589	TUBO CARBOPRESS NV 8X14 ECO	PIPE CARBOPRESS NV 8X14 ECO
13180	VITE TCCE 6x16 UNI 7984 Z.B.TESTA RIBAS	SCREW TCCE 6x16 UNI 7984
0754	TUBO ARMORVIN HNA 10 RIF. RPQ0191	PIPE ARMORVIN HNA 10 RIF. RPQ0191
1067	POMPA ACQUA 12.V+CONNETTORE	WATER PUMP 12.V+CONNECTOR
1070	FASCETTA VELOX 5 TUBO 8-19	HOSE CLAMP VELOX 5 TUBO 8-19
1073	TANICA ACQUA LT.15 CCC0206	WATER TANK LT.15 CCC0206
1111	PORTA TANICA	TANK HOLDER
1215	RONDELLA PIANA 10x30 Z.B.	WASH PLAIN 10x30 Z.B.
1476	RACCORDO PER SERBATOIO	FITTING FOR TANK
1605	SERBATOIO BENZINA HCS	PETROL TANK FOR HCS
1615	POMPETTA ASPIRAZIONE BENZINA HCS	FUEL SUCTION PUMP HCS
1934	TAPPO 2 LOBI BAIONETTA D.60	CAP FOR PETROL TANK
1935	GHIERA A BAIONETTA T.60 DN.60	BAYONET RING
2656	RONDELLA FERRO-GOMMA D12	WASHER IRON-RUBBER D12

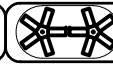
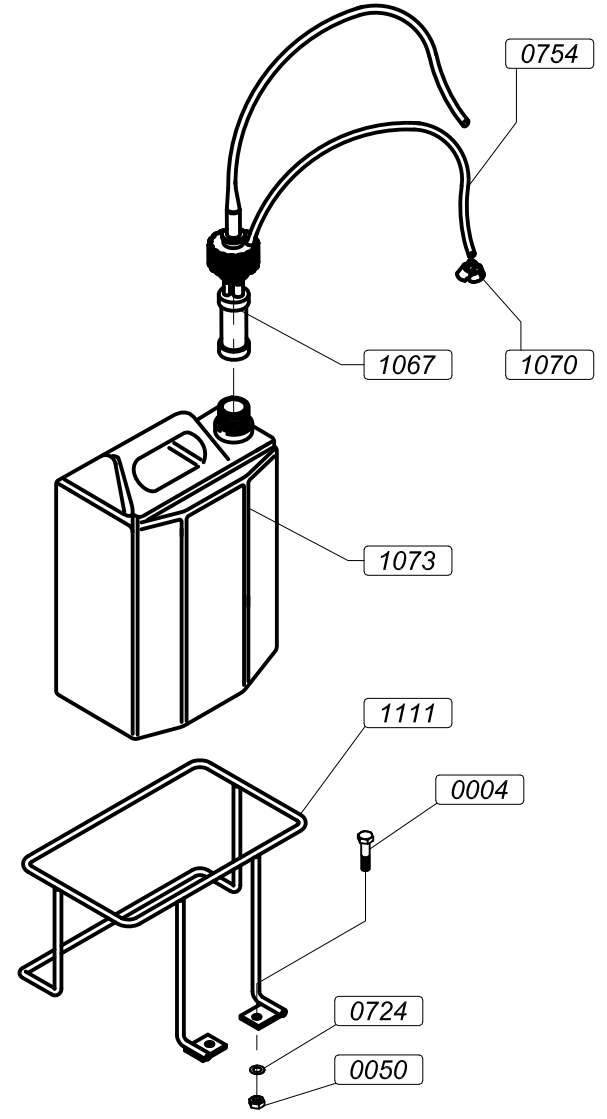
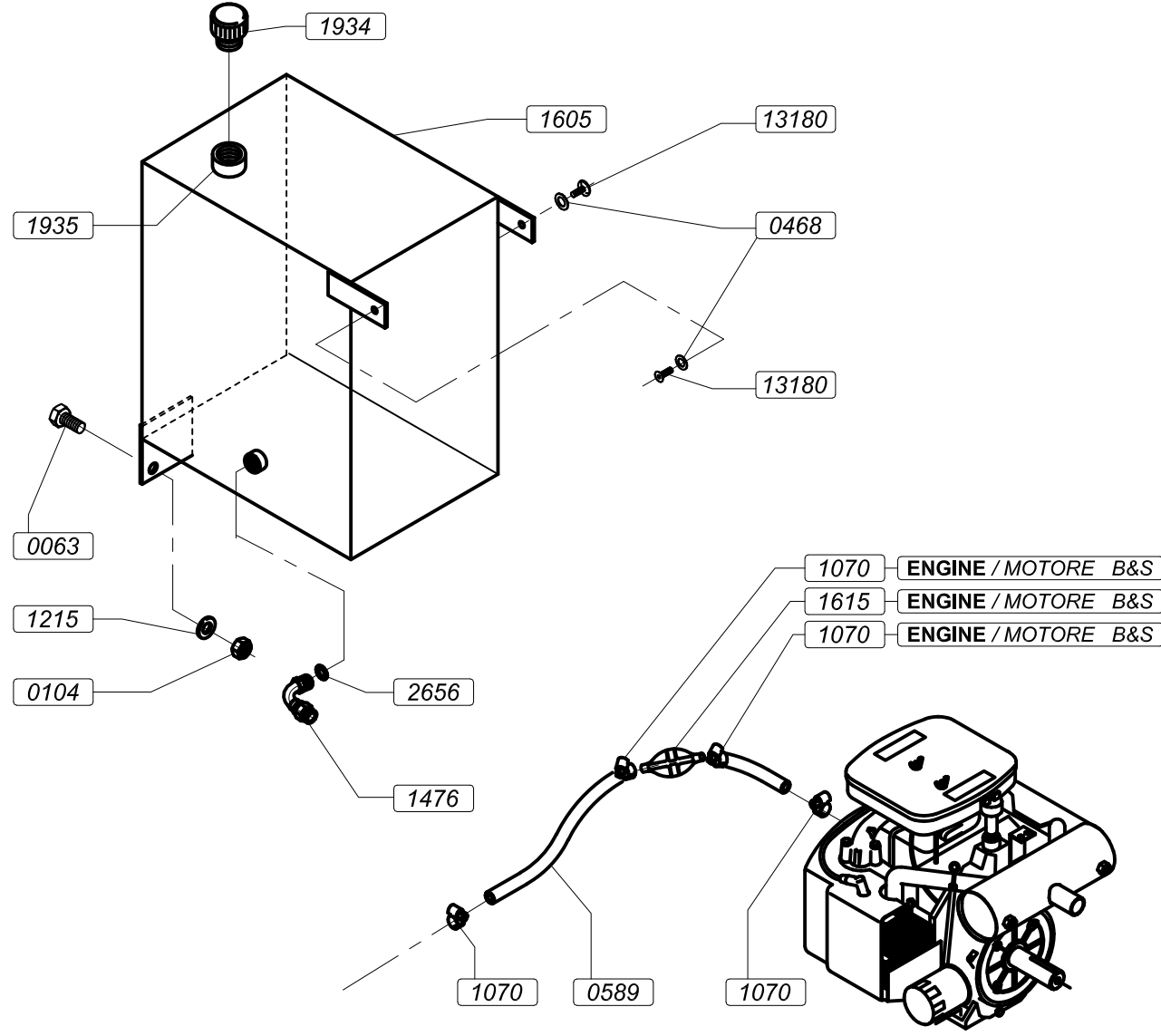
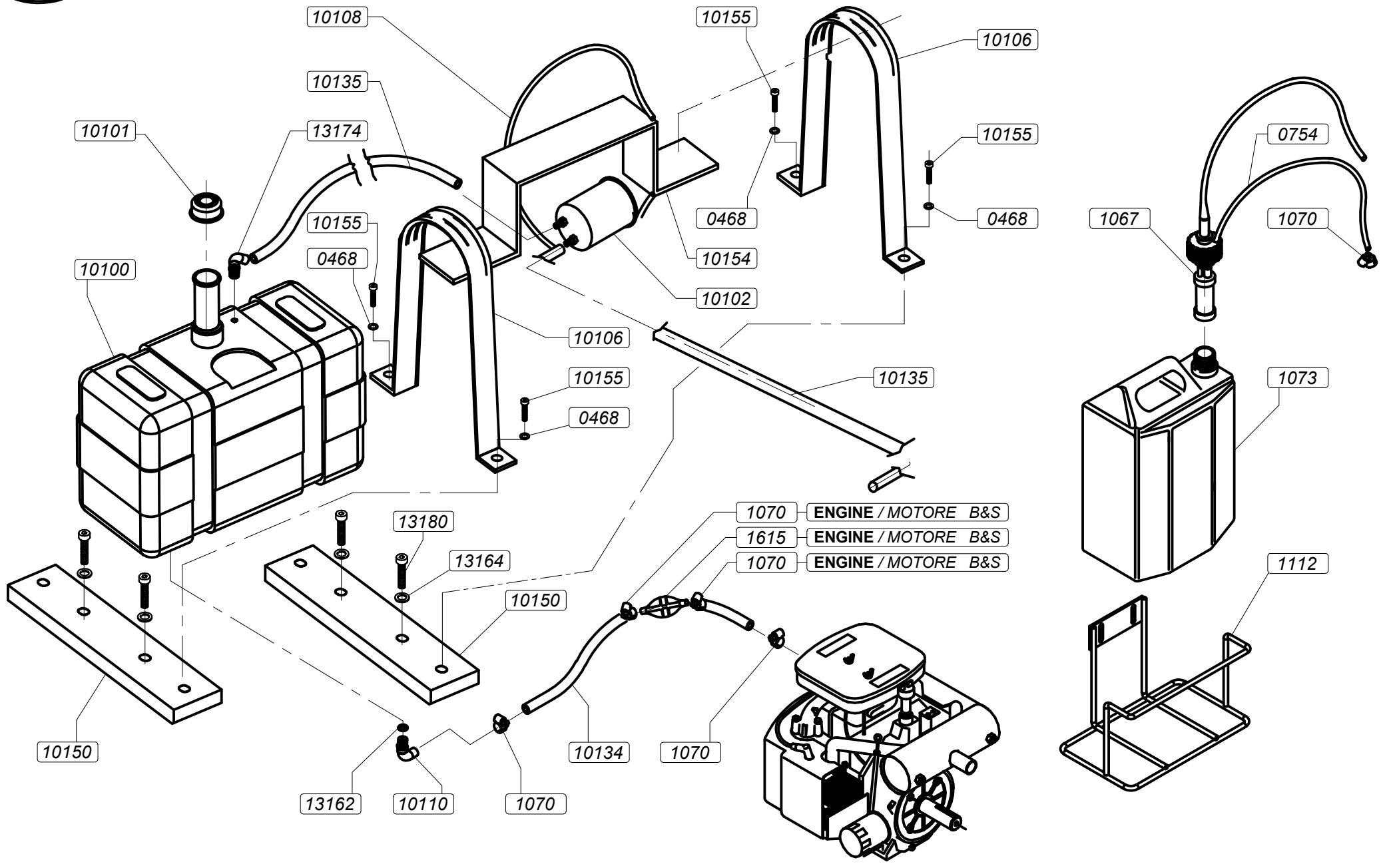
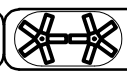
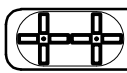
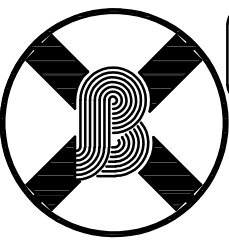

COD.	DESCRIZIONE (I)	DESCRIPTION (GB)
0468	RONDELLA 6x18X1,5 Z.B.	WASHER 6x18X1,5 ZINC PLATED
0754	TUBO ARMORVIN HNA 10 RIF. RPQ0191	PIPE ARMORVIN HNA 10 RIF. RPQ0191
1067	POMPA ACQUA 12.V+CONNETTORE	WATER PUMP 12.V+CONNECTOR
1070	FASCETTA VELOX 5 TUBO 8-19	HOSE CLAMP VELOX 5 TUBO 8-19
1073	TANICA ACQUA LT.15 CCC0206	WATER TANK LT.15 CCC0206
1112	PORTA TANICA MK8-90 HCS/OL-120 HCS	SUPPORT FUEL TANK MK8-90 HCS/OL-120 HCS
1615	POMPETTA ASPIRAZIONE BENZINA HCS	FUEL SUCTION PUMP HCS
10100	TANICA BENZINA CARB-EPA 5 GALLONI	FUEL TANK CARB-EPA 5 GALLONS
10101	TAPPO 2-1/4" TANICA BENZ. NORMA CARB-EPA	PLUG 2-1/4" FUEL TANK
10102	CARBON CANISTER CARB-EPA 400 cc	CARBON CANISTER CARB-EPA 400 cc
10106	CINGHIA FERRO TANICA BENZ.NORMA CARB-EPA	IRON BELT FOR TANK FUEL CARB-EPA
10108	FASCETTA SUPP. CARBON CANISTER	HOSE CLAMP CARBON CANISTER
10110	PORTAGOMMA 90° TUBO D. 6 FIL. 1/8"	FITTING 90° PIPE D. 6 FIL. 1/8"
10134	TUBO BENZINA TANICA CARB-EPA RT. DA 50ft	TANK FUEL PIPE CARB-EPA RT. DA 50ft
10135	TUBO FUMI A NORMA CARB-EPA RT. DA 50ft.	PIPE SMOKE CARB-EPA RT. DA 50ft.
10150	STAFFA SERB.BENZ.EPA	BRACKET TANK FUEL
10154	STAFFA ALLUMINIO CARB-EPA	ALUMINIUM BRACKET EPA
10155	VITE TCCE 6x30 UNI 5931 Z.B.	SOCKET HEAD CAP SCREW 6X30 - 5931 ZINC P.
13162	RONDELLA FERRO-GOMMA 1/8"	WASHER IRON-RUBBER 1/8"
13164	RONDELLA ZIGRIN.D.6 ZINC.B.-SCHNORR-	WASHER D.6 G.W. -SCHNORR-
13174	RACCORDO 90° PER SERBATOIO	CONNECTOR 90° FOR TANK
13180	VITE TCCE 6x16 UNI 7984 Z.B.TESTA RIBAS	SCREW 6x16 UNI 7984 ZINC PLATED

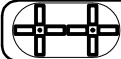
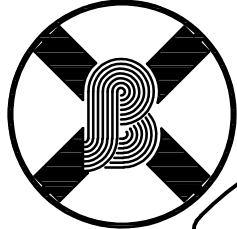

MK8-120 HCS



MK10-120 HCS

**TABLE
TAVOLA H1**

4385 ENGINE / MOTORE KOHLER CH730 23.5HP

4391 ENGINE / MOTORE KOHLER CH742 25HP

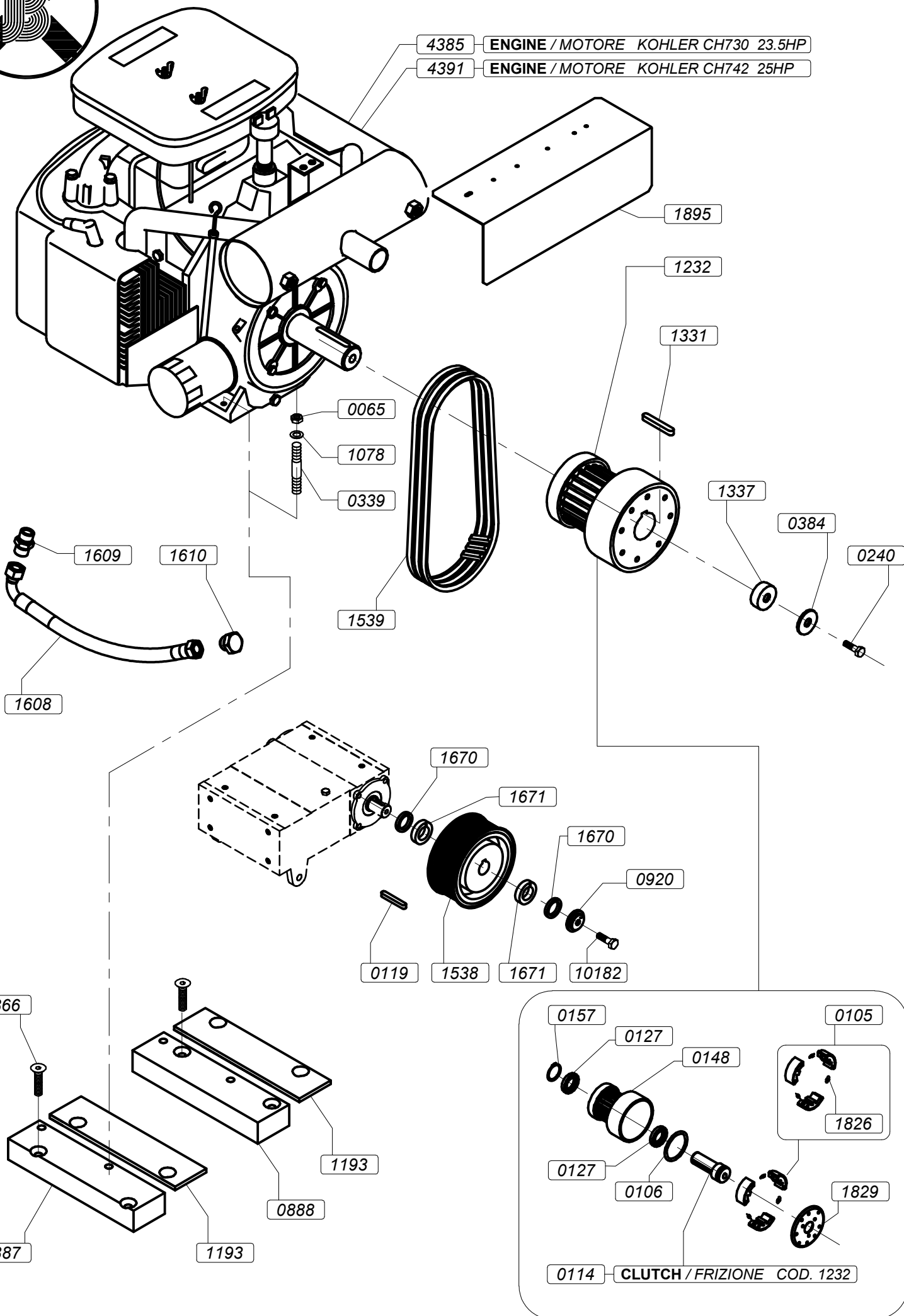

COD.	DESCRIZIONE (I)	DESCRIPTION (GB)
0065	DADO M10 5588 Z.B.	NUT M10 5588 ZINC PLATED
0105	SERIE MASSE FRIZIONI DENTATE HTD PER COD. 1232/33/34 RIF.MF621800332	FLYWEIGHT CLUTCH HTD RIF.MF621800332
0106	ANELLO X FRIZIONE DENTATA COD.1232/33/34	JUNT RING CLUTCH COD.1232/33/34
0114	ALBERO TRASCIN.D.28.57 X FRIZ.COD.1232	CLUTCH SHAFT D.28.57 COD.1232
0119	CHIAVETTA 8x7x30 - 6604A	SMALL KEY 8x7x30 - 6604A
0127	CUSCINETTO 6010 2RS X FRIZIONE DENTATA	BEARING 6010 2RS FOR TOOTHED CLUTCH
0148	CAMPANA Ø 138 X FRIZ.DENT COD.1232/33/34	UPPER HEAD Ø 138 FOR TOOTHED CLUTCH COD.1232/33/34
0157	SEEGER "E" 50 UNI 7435-75 X FR.DENTATA	SEEGER "E" 50 UNI 7435-75
0240	VITE TE UNF 7/16x2"1/4	HEX HEAD BOLT UNF 7/16x2"1/4
0339	PRIGIONIERO M10 L=40 DIN 939 Z.B.	STUD M10 L=40 DIN 939 ZINC PLATED
0384	RONDELLA PIANA D.12 6592 ZB	WASHER D.12 6592 ZINC PLATED
0887	STAFFA MOT.ANTER.KOHLER 25/27	ANTERIOR SUPPORT KOHLER ENGINE 25/27
0888	STAFFA MOT.POSTER.KOHLER 25/27	REAR SUPPORT KOHLER ENGINE 25/27
0920	RONDELLA FISS.	FIXING WASHER
1078	RONDELLA ZIGRIN.D10 ZINC.B.	WASHER D10 ZINC PLATED
1193	STAFFA MOTORE ANT./POST.KOHL 50X15 L=180	ANT./POST. SUPPORT KOHL 50X15 L=180
1232	FRIZIONE DENTATA D.28.575 MK8-90/120/OL90/120	TOOTHED CLUTCH D.28.575
1331	CHIAVETTA 38,1x6,3x6,3 B.& S	KEY 38,1x6,3x6,3 B.& S
1337	RONDELLA BLOCC.	LOCKING WASHER
1538	PULEGGIA Z 56X50 M8 D.25 H7 CH8	PULLEY Z 56X50 M8 D.25 H7 CH8
1539	CINGHIA DENTATA HTD 8M 50X880 HCS	TOOTHED BELT HTD 8M 50X880 HCS
1608	TUBO B.P.R6 3/8"-3/8" F90° 3/8"	PIPE B.P.R6 3/8"-3/8" F90° 3/8"
1609	NIPLES GAS NPT-CILINDRICO 3/8"	NIPPLES GAS NPT 3/8"
1610	TAPPO TESTA ESAGONALE GAS 3/8"	HEX HEAD CAP GAS 3/8"
1670	BOCCOLA 35X5 FORO D.26	BUSHING 35X5 HOLE D.26
1671	BOCCOLA 35X10 FORO D.26	BUSHING 35X10 HOLE D.26
1826	MOLLA PER FRIZIONE BARIKELL 115E DENTATA COD. 1232/33/34	SPRING FOR CLUTCH BARIKELL 115E
1829	COPERCHIO FRIZIO.BARIKELL 115 E DENTATA	CLUTCH COVER BARIKELL 115
1866	VITE VSP 10X55 Z.B. 5933	H.S.C.H. SCREW 10X55 UNI 5933 ZINC PLATED
1895	PROTEZIONE MARMITTA	MUFFLER PROTECTION
4385	MOTORE KOHLER 23.5HP CH730-3000	ENGINE KOHLER 23.5HP CH730-3000
4391	MOTORE KOHLER 25HP CH742-3103	ENGINE KOHLER 25HP CH742-3103

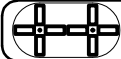

MK8-120 HCS



MK10-120 HCS

**TABLE
TAVOLA H2**

4377 ENGINE / MOTORE KOHLER ECH98 38HP

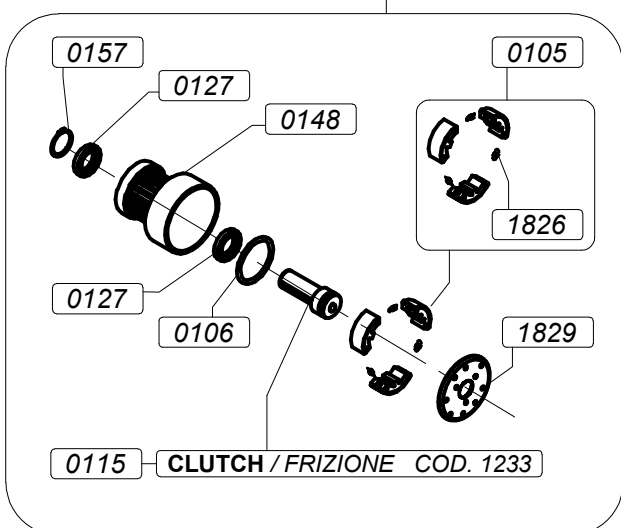
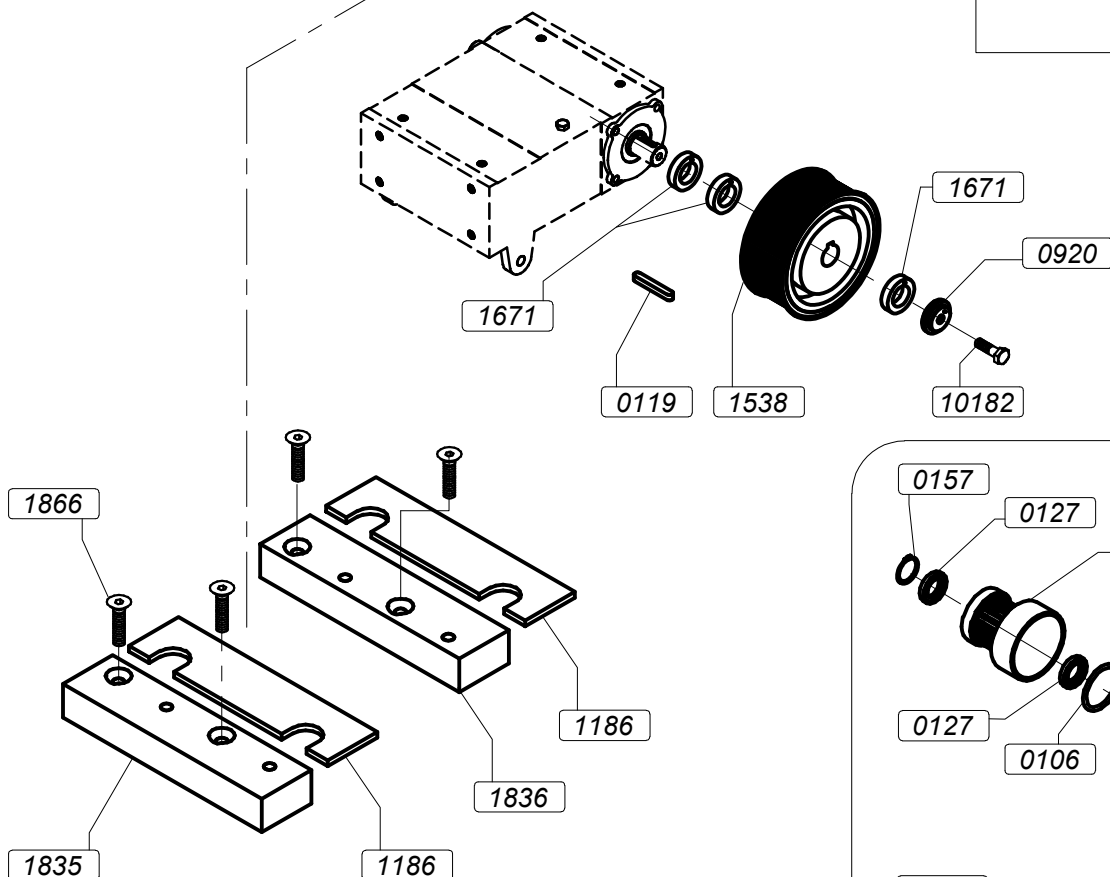
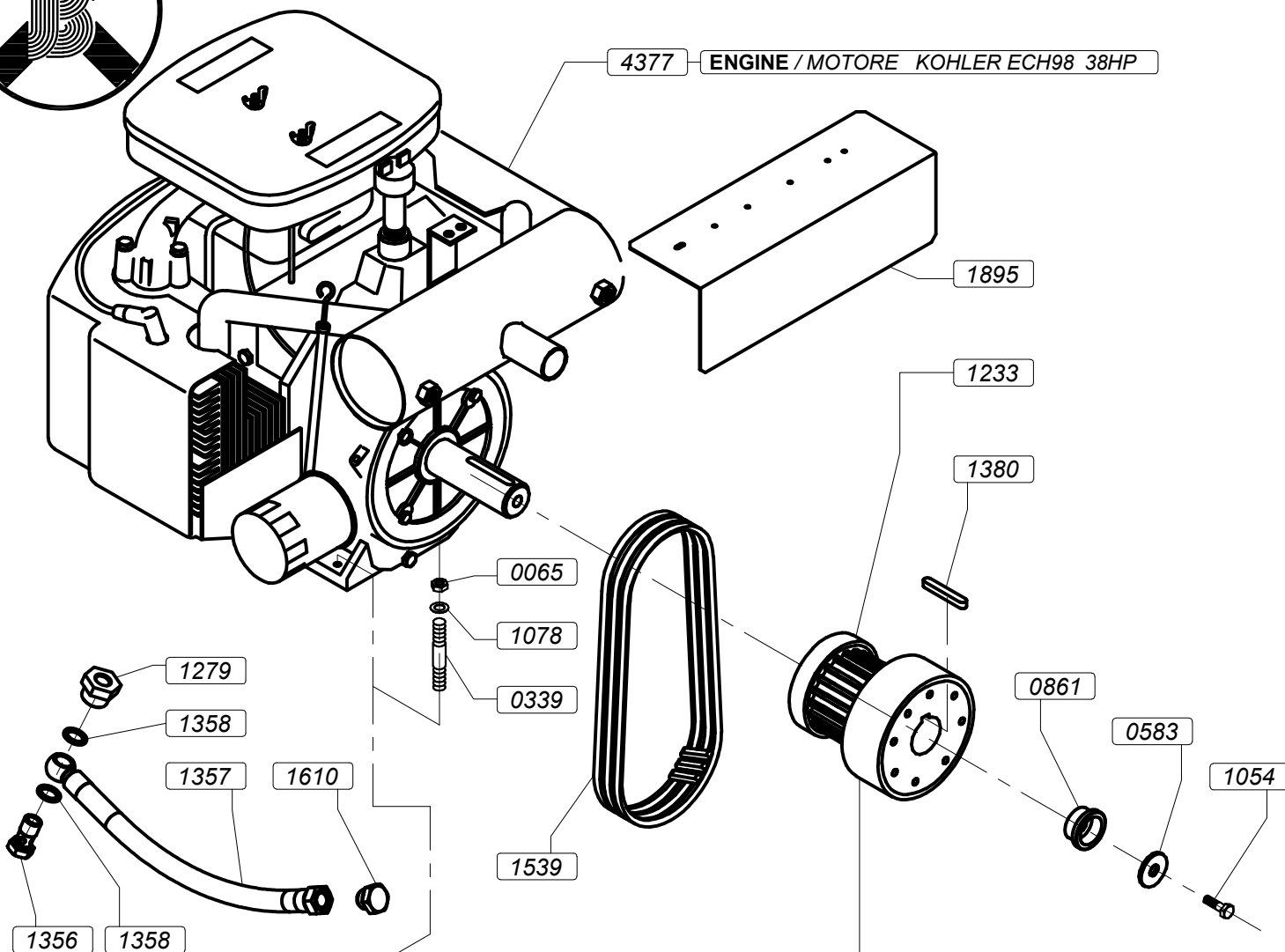

0115 CLUTCH / FRIZIONE COD. 1233

COD.	DESCRIZIONE (I)	DESCRIPTION (GB)
0065	DADO M10 5588 Z.B.	NUT M10 5588 ZINC PLATED
0105	SERIE MASSE FRIZIONI DENTATE HTD PER COD. 1232/33/34 RIF.MF621800332	FLYWEIGHT CLUTCH HTD RIF.MF621800332
0106	ANELLO X FRIZIONE DENTATA COD.1232/33/34	JUNT RING CLUTCH COD.1232/33/34
0115	ALBERO TRASCIN.D.36.51 PER FRIZ.COD.1233	CLUTCH SHAFT D.36,51 COD.1233
0119	CHIAVETTA 8x7x30 - 6604A	SMALL KEY 8x7x30 - 6604A
0127	CUSCINETTO 6010 2RS X FRIZIONE DENTATA	BEARING 6010 2RS FOR TOOTHED CLUTCH
0148	CAMPANA Ø 138 X FRIZ.DENT COD.1232/33/34	UPPER HEAD Ø 138 FOR TOOTHED CLUTCH COD.1232/33/34
0157	SEEGER "E" 50 UNI 7435-75 X FR.DENTATA	SEEGER "E" 50 UNI 7435-75
0339	PRIGIONIERO M10 L=40 DIN 939 Z.B.	STUD M10 L=40 DIN 939 ZINC PLATED
0583	RONDELLA GROWER D.16 ZB	WASH PLAIN D.16
0861	BOCCOLA FRIZIONE PAF115/B Z.B. B&S 31/35	BUSH FOR PAF115/B
0920	RONDELLA FISS.	FIXING WASHER
1054	VITE TE 5/8x2" UNF	SCREW TE 5/8x2" UNF
1078	RONDELLA ZIGRIN.D10 ZINC.B.	WASHER D10 ZINC PLATED
1186	SPESSORE IN ALLUM.151X30 SP.1	THICKENER 151X30X1
1233	FRIZIONE DENTATA D.36,5	TOOTHED CLUTCH D.36,5
1279	RACC. SCARICO OLIO PER KOHLER 36-40 Z.B.	FITTING FOR OIL DRAIN
1356	BULLONE FORATO 12X1,5mm TUBO SCAR.OLIO	PIERCED BOLT 12X1.5
1357	TUBO T.PLAS.R7 1/4" FD3/8"-1/4	PLASTIC PIPE R7 HONDA 13 HP
1358	RONDELLA RAME 12X18X1,5 PER BULLONE FOR.	WASH PLAIN D.12X18X1,5
1380	CHIAVETTA 9,3x9,3x90	KEY 9,3x9,3x90
1538	PULEGGIA Z 56X50 M8 D.25 H7 CH8	PULLEY Z 56X50 M8 D.25 H7 CH8
1539	CINGHIA DENTATA HTD 8M 50X880 HCS	TOOTHED BELT HTD 8M 50X880 HCS
1610	TAPPO TESTA ESAGONALE GAS 3/8"	HEX HEAD CAP GAS 3/8"
1671	BOCCOLA 35X10 FORO D.26	BUSHING 35X10 HOLE D.26
1826	MOLLA PER FRIZIONE BARIKELL 115E DENTATA COD. 1232/33/34	SPRING FOR CLUTCH BARIKELL 115E
1829	COPERCHIO FRIZIO.BARIKELL 115 E DENTATA	CLUTCH COVER BARIKELL 115
1835	STAFFA MOT.ANT.B.& S.31/35 HP	FRONTAL ENGINE BRACKET B&S 31/35HP
1836	STAFFA MOT.POST.B.& S.31/35 HP	BACK ENGINE BRACKET B&S 31/35HP
1866	VITE VSP 10X55 Z.B. 5933	H.S.C.H. SCREW 10X55 UNI 5933 ZINC PLATED
1895	PROTEZIONE MARMITTA	MUFFLER PROTECTION
4377	MOTORE KOHLER ECH98 38HP	ENGINE KOHLER ECH98 38HP
10182	VITE TE 8x30 10.9 5739 ZINC.B.	SOCKET HEAD CAP SCREW 8x30 10.9 5739 ZINC P.

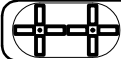

MK8-120 HCS



MK10-120 HCS

**TABLE
TAVOLA H3**

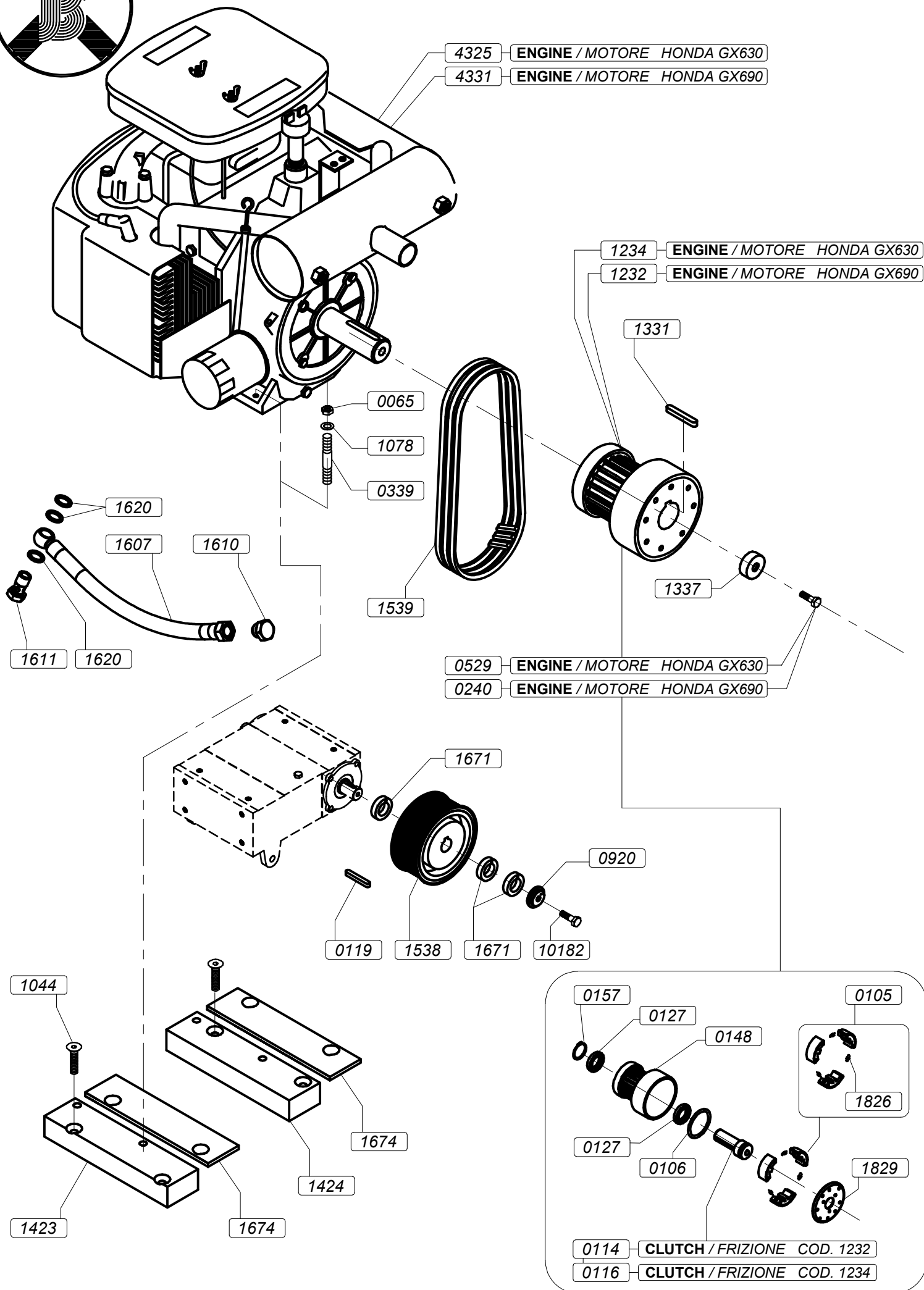

COD.	DESCRIZIONE (I)	DESCRIPTION (GB)
0065	DADO M10 5588 Z.B.	NUT M10 5588
0105	SERIE MASSE FRIZIONI DENTATE HTD PER COD. 1232/33/34 RIF.MF621800332	FLYWEIGHT CLUTCH HTD RIF.MF621800332
0106	ANELLO X FRIZIONE DENTATA COD.1232/33/34	JUNT RING CLUTCH COD.1232/33/34
0114	ALBERO TRASCIN.D.28.57 X FRIZ.COD.1232	CLUTCH SHAFT D.28.57 COD.1232
0116	ALBERO TRASCIN.D.36.51 X FRIZ.COD.1234	CLUTCH SHAFT D.36,51 COD.1234
0119	CHIAVETTA 8x7x30 - 6604A	SMALL KEY 8x7x30 - 6604A
0127	CUSCINETTO 6010 2RS X FRIZIONE DENTATA	BEARING 6010 2RS FOR TOOTHED CLUTCH
0148	CAMPANA Ø 138 X FRIZ.DENT COD.1232/33/34	UPPER HEAD Ø 138 FOR TOOTHED CLUTCH COD.1232/33/34
0157	SEEGER "E" 50 UNI 7435-75 X FR.DENTATA	SEEGER "E" 50 UNI 7435-75
0240	VITE TE UNF 7/16x2"1/4	HEX HEAD BOLT UNF 7/16x2"1/4
0339	PRIGIONIERO M10 L=40	STUD M10 L=40 B&S.31HP / 35HP
0384	RONDELLA PIANA D.12 6592 ZB	WASHER D.12 6592 ZINC PLATED
0920	RONDELLA FISS.	FIXING WASHER
1044	VITE VSP 10X75 UNI 5933 Z.B.	SCREW 6x18 UNI 5933
1078	RONDELLA ZIGRIN.D10 ZINC.B.	PLAIN WASHER D.10
1232	FRIZIONE DENTATA D.28.575	TOOTHED CLUTCH D.28.575
1234	FRIZIONE DENTATA D.25.4	TOOTHED CLUTCH D.25.4
1331	CHIAVETTA 38,1x6,3x6,3 B.& S 31HP	KEY 38,1x6,3x6,3 B. & S 31HP
1337	RONDELLA BLOCC.	LOCKING WASHER
1423	STAFFA MOT.ANTE.HONDA	FRONT BRACKET ENGINE HONDA
1424	STAFFA MOT.POSTER.HONDA	REAR BRACKET ENGINE HONDA
1538	PULEGGIA Z 56X50 M8 D.25 H7 CH8	PULLEY Z 56X50 M8 D.25 H7 CH8
1539	CINGHIA DENTATA HTD 8M 50X880 HCS	TOOTHED BELT HTD 8M 50X880 HCS
1607	TUBO T.PLAS.R7 1/4" FD3/8"-1/4	PIPE R7 1/4" FD3/8"-1/4
1610	TAPPO TESTA ESAGONALE GAS 3/8"	HEX HEAD CAP GAS 3/8"
1611	BULLONE FORATO 14X1.5mm X TUBO SCAR.OLIO	BOLT HOLE 14X1.5mm FOR PIPE OIL
1620	RONDELLA RAME 14X20X1,5	WASHER COPPER 14X20X1,5
1671	BOCCOLA 35X10 FORO D.26	BUSHING 35X10 HOLE D.26
1674	SUPPORTO MOTORE UNIVERSALE	ENGINE BRACKET
1826	MOLLA PER FRIZIONE BARIKELL 115E DENTATA COD. 1232/33/34	SPRING FOR CLUTCH BARIKELL 115E
1829	COPERCHIO FRIZIO.BARIKELL 115 E DENTATA	CLUTCH COVER BARIKELL 115
4325	MOTORE HONDA GX 630RH 20HP	ENGINE HONDA GX 630RH 20HP
4331	MOTORE HONDA GX690 RH	ENGINE HONDA GX690 RH
10182	VITE TE 8x30 10.9 5739 ZINC.B.	SOCKET HEAD CAP SCREW 8x30 10.9 5739 ZINC PLATED



MK8-120 HCS



MK10-120 HCS

TABLE TAVOLA H4

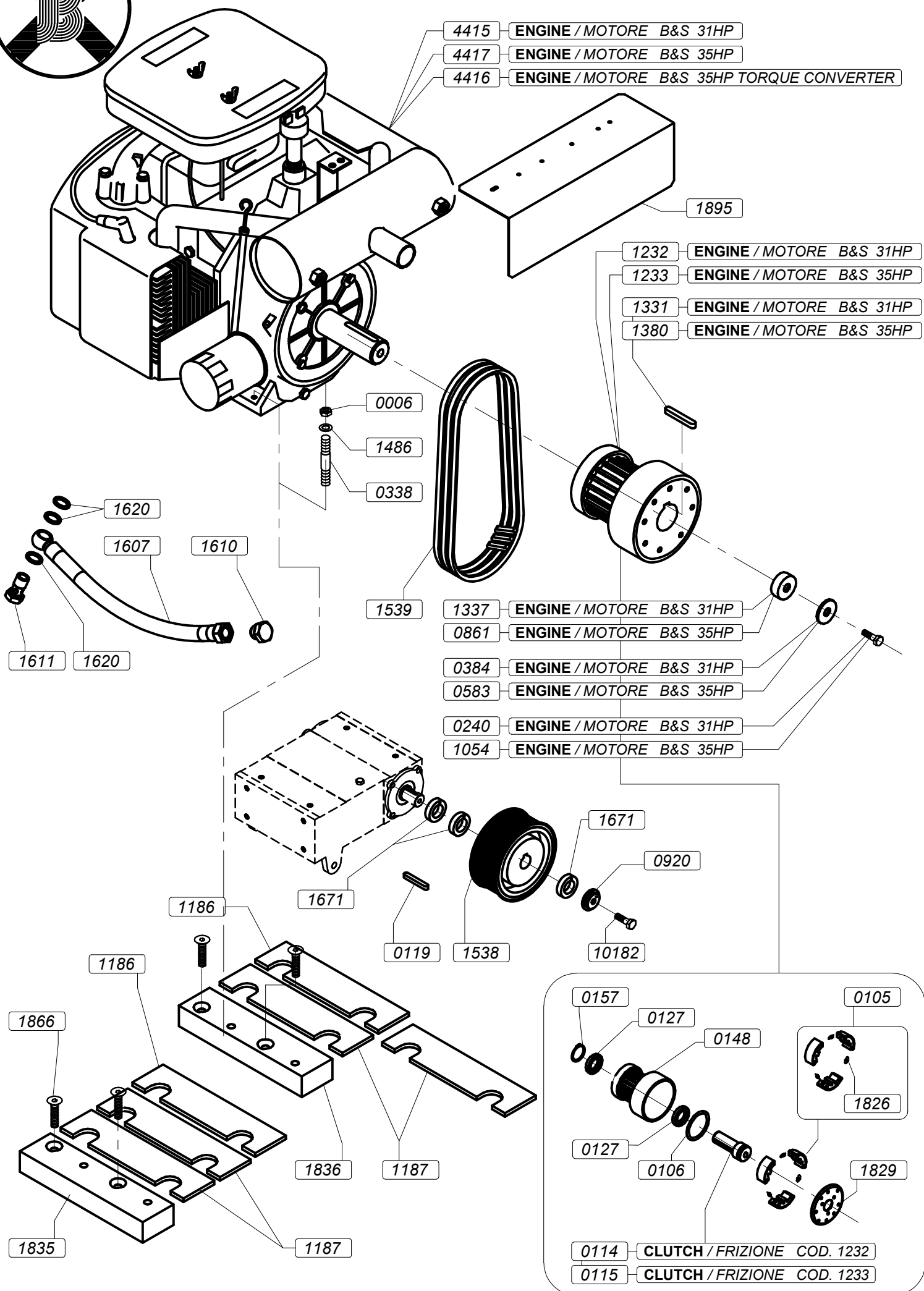

COD.	DESCRIZIONE (I)	DESCRIPTION (GB)
0006	DADO M8 UNI 5588 Z.B.	NUT M8 UNI 5588 ZINC PLATED
0105	SERIE MASSE FRIZIONI DENTATE HTD PER COD. 1232/33/34 RIF.MF621800332	FLYWEIGHT CLUTCH HTD RIF.MF621800332
0106	ANELLO X FRIZIONE DENTATA COD.1232/33/34	JUNT RING CLUTCH COD.1232/33/34
0114	ALBERO TRASCIN.D.28.57 X FRIZ.COD.1232	CLUTCH SHAFT D.28.57 COD.1232
0115	ALBERO TRASCIN.D.36.51 X FRIZ.COD.1233	CLUTCH SHAFT D.36.51 COD.1233
0119	CHIAVETTA 8x7x30 - 6604A	SMALL KEY 8x7x30 - 6604A
0127	CUSCINETTO 6010 2RS X FRIZIONE DENTATA	BEARING 6010 2RS FOR TOOTHED CLUTCH
0148	CAMPANA Ø 138 X FRIZ.DENT COD.1232/33/34	UPPER HEAD Ø 138 FOR TOOTHED CLUTCH COD.1232/33/34
0157	SEEGER "E" 50 UNI 7435-75 X FR.DENTATA	SEEGER "E" 50 UNI 7435-75
0240	VITE TE UNF 7/16x2"1/4	HEX HEAD BOLT UNF 7/16x2"1/4
0338	PRIGIONIERO M8 L=65 X B&S.31HP / 35HP	STUD M8 L=65 B&S.31HP / 35HP
0384	RONDELLA PIANA D.12 6592 ZB	WASHER D.12 6592 ZINC PLATED
0583	RONDELLA GROWER D.16 ZB	WASHER GROWER D.16 ZINC PLATED
0861	BOCCOLA FRIZIONE PAF115/B Z.B. B&S 31/35	CLUTCH BUSHING PAF115/B ZINC PLATED B&S 31/35
0920	RONDELLA FISS.	FIXING WASHER
1054	VITE TE 5/8x2" UNF	SOCKET HEAD CAP SCREW 5/8x2" UNF
1186	SPESSORE IN ALLUM.151X30 SP.1	ALUMINUM SPACER 151X30 SP.1
1187	SPESSORE IN ALLUM.149X30 SP.2	ALUMINUM SPACER 149X30 SP.2
1232	FRIZIONE DENTATA D.28.575	TOOTHED CLUTCH D.28.575
1233	FRIZIONE DENTATA D.36.5	TOOTHED CLUTCH D.36.5
1331	CHIAVETTA 38,1x6,3x6,3 B.& S 31HP	KEY 38,1x6,3x6,3 B.& S 31HP
1337	RONDELLA BLOCC.	LOCKING WASHER
1380	CHIAVETTA B.& S. 35HP	KEY B.& S. 35HP
1486	RONDELLA ZIGRINATA D.8 Z.B.	WASHER D.8 ZINC PLATED
1538	PULEGGIA Z 56X50 M8 D.25 H7 CH8	PULLEY Z 56X50 M8 D.25 H7 CH8
1539	CINGHIA DENTATA HTD 8M 50X880 HCS	TOOTHED BELT HTD 8M 50X880 HCS
1607	TUBO T.PLAS.R7 1/4" FD3/8"-1/4	PIPE R7 1/4" FD3/8"-1/4
1610	TAPPO TESTA ESAGONALE GAS 3/8"	HEX HEAD CAP GAS 3/8"
1611	BULLONE FORATO 14X1.5mm X TUBO SCAR.OLIO	BOLT HOLE 14X1.5mm FOR PIPE OIL
1620	RONDELLA RAME 14X20X1,5	WASHER COPPER 14X20X1,5
1671	BOCCOLA 35X10 FORO D.26	BUSHING 35X10 HOLE D.26
1826	MOLLA PER FRIZIONE BARIKELL 115E DENTATA COD. 1232/33/34	SPRING FOR CLUTCH BARIKELL 115E
1829	COPERCHIO FRIZIO.BARIKELL 115 E DENTATA	CLUTCH COVER BARIKELL 115
1835	STAFFA MOT.ANT.B.& S.31/35 HP	FRONT BRACKET ENGINE B.& S.31/35 HP
1836	STAFFA MOT.POS.B.& S.31/35 HP	REAR BRACKET ENGINE B.& S.31/35 HP
1866	VITE VSP 10X55 Z.B. 5933	SCREW VSP 10X55 Z.B. 5933
1895	PROTEZIONE MARMITTA	MUFFLER PROTECTION
4415	MOTORE B.& S.VANGUARD 31HP	ENGINE B.& S.VANGUARD 31HP
4416	MOTORE B.& S.VANGUARD 35HP D.28,575	ENGINE B.& S.VANGUARD 35HP D.28,575
4417	MOTORE B.& S.VANGUARD 35HP D. 36,5	ENGINE B.& S.VANGUARD 35HP D. 36,5
10182	VITE TE 8x30 10.9 5739 ZINC.B.	SOCKET HEAD CAP SCREW 8x30 10.9 5739 ZINC PLATED



TORQUE CONVERTER

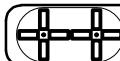

MK8-120 HCS



MK10-120 HCS

TABLE
TAVOLA **I**

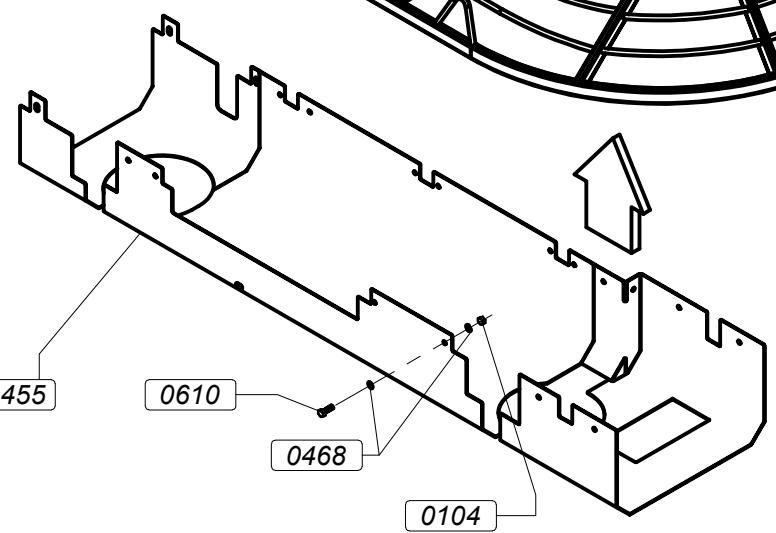
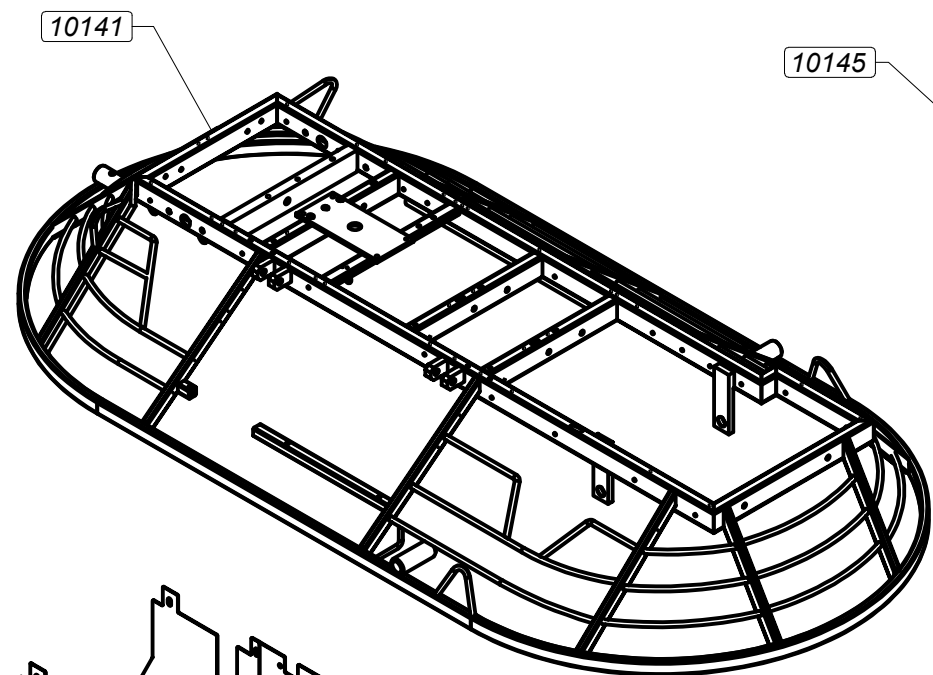

13203 ENGINE / MOTORE B&S

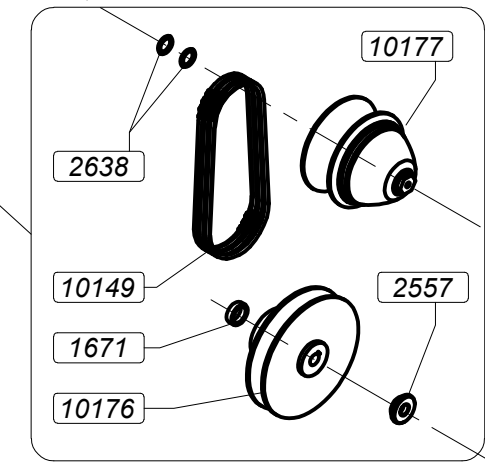

1215

10126 ENGINE / MOTORE B&S

1058 ENGINE / MOTORE KUBOTA

10140 ENGINE / MOTORE KOHLER

10146 ENGINE / MOTORE B&S

0924 ENGINE / MOTORE KUBOTA

10166 ENGINE / MOTORE KOHLER

13300

ENGINE / MOTORE B&S 10147

ENGINE / MOTORE KUBOTA 10010

ENGINE / MOTORE KOHLER 10167

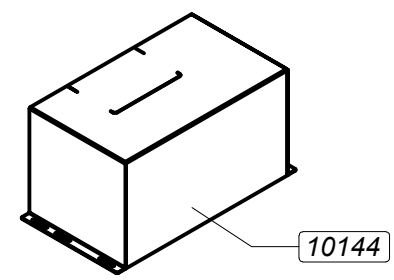

COD.	DESCRIZIONE (I)	DESCRIPTION (GB)
0104	DADO BLOKM6 -DIN 985 Z.B.	BLOK NUT M6 985
0468	RONDELLA 6x18X1,5 Z.B.	PLAIN WASHER 6x18X1,5
0610	VITE TE 6x40 UNI 5737 Z.B.	SCREW TE 6x40 UNI 5737
0924	STAFFA ANTER.SUPP.MOTORE KUBOTA 25HP	ANTERIOR BRACKET FOR KUBOTA ENGINE 25 HP
1058	VITE TE 10x100 5739 ZB T.FIL	HEX HEAD BOLT 10x100 5739 ZINC PLATED
1671	BOCCOLA 35X10 FORO D.26	BUSHING 35X10 HOLE D.26
2557	RONDELLA FISSAGGIO PULEGGIA	PULLEY FIX WASHER
2638	BOCCOLA 29-39 SP.2 GREZZO	BUSHING 29-39 TH.2
10010	STAFFA POST. SUPP.MOTORE KUBOTA 25HP	REAR BRACKET FOR KUBOTA ENGINE 25 HP
10126	VITE TE UNF 7/16x5"	HEX HEAD BOLT 7/16X5"
10140	VITE TE UNF 7/16x4"	SCREW TE UNF 7/16x4"
10144	CARTER FRIZIONE MK8-90/120 CON VARIATORE	CLUTCH CARTER MK8-90/120 WITH VARIABLE SPEED
10145	FRIZIONE TORQUE CONVERTER	CLUTCH TORQUE CONVERTER
10146	STAFFA MOT.ANT.B.& S.31/35 HP c/variato	BRACKET ENG.ANT.B.& S.31/35 HP WITH VARIABLE SPEED
10147	STAFFA MOT.POST.B.& S.31/35 HP c/variato	BRACKET ENG.POST.B.& S.31/35 HP WITH VARIABLE SPEED
10149	CINGHIA X TORQUE CONVERTER 0400-0338	BELT FOR TORQUE CONVERTER
10166	STAFFA MOT.ANT.KOHLER TORQUE CONVERTER	ANTERIOR BRACKET FOR KOHLER TORQUE CONVERTER
10167	STAFFA MOT.POST.KOHLER TORQUE CONVERTER	REAR BRACKET FOR KOHLER TORQUE CONVERTER
10176	PULEGGIA CONDOTTA TORQUE CONVERTER	TORQUE CONVERTER DRIVEN PULLEY
10177	PULEGGIA MOTRICE TORQUE CONVERTER	TORQUE CONVERTER DRIVER PULLEY
11455	TUNNEL PROTEZIONE MK8-120	PROTECTION TUNNEL MK8-120
1215	RONDELLA PIANA 10x30 Z.B.	WASHER 10x30 ZINC PLATED
10141	TELAIO PROT.MK8-120	PROTECTION FRAME MK8-120
13203	DISTANZIALE D.45X20 D.28.8	SPACER D.45X20 D.28.8
13300	VITE TCCE 8x55 12.9 UNI5931 DIN 912 Z.B.	SCREW TCCE 8x55 12,9 UNI5931

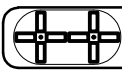

MK8-120 HCS

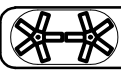

MK10-120 HCS

**TABLE
TAVOLA L**

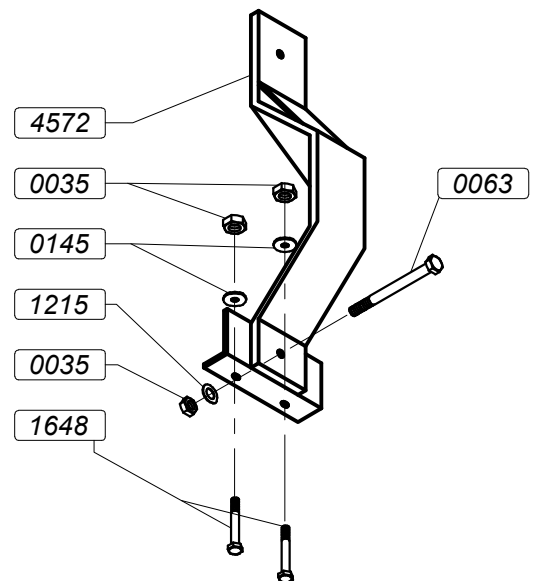
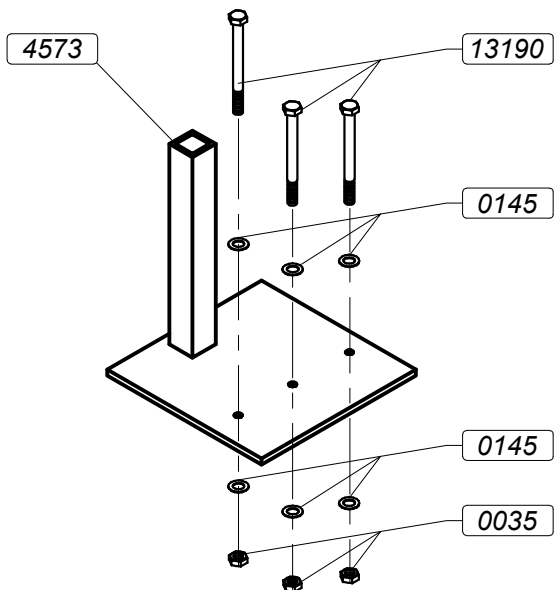
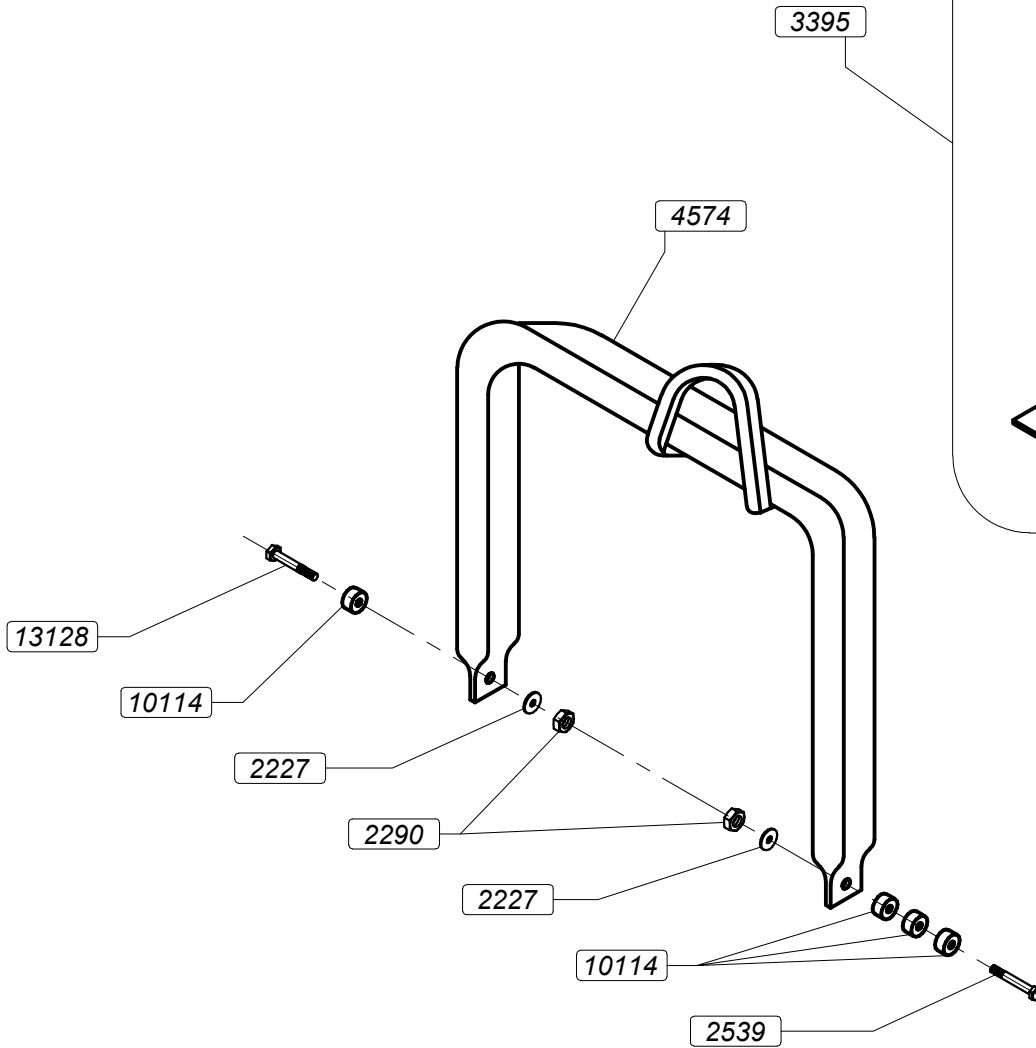
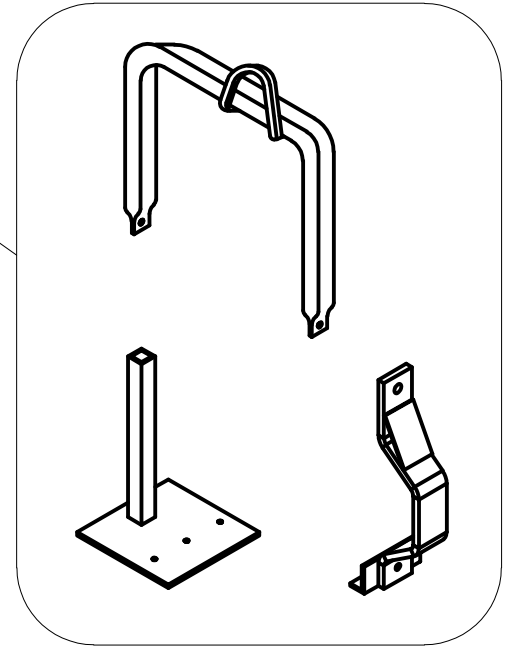

COD.	DESCRIZIONE (I)	DESCRIPTION (GB)
0035	DADO BLOKM10 -985 - Z.B.	SELF-LOCKING NUT M10 -985 ZINC PLATED
0063	VITE TE 10x50 -5737 - Z.B.	HEXAGONAL SCREW 10X50 5737
0145	RONDELLA PIANA 10x21 6592 Z.B.	WASHER 10x21 6592 ZINC PLATED
10114	DISTANZIALE D.41-16,5H12 Z.B.	SPACER D.41-16,5H12
1215	RONDELLA PIANA 10x30 Z.B.	WASHER 10x30 ZINC PLATED
13128	VITE TE 16X75 5737 ZINCATA	SCREW TE 16X75 5737
13190	VITE TE 10X85 Z.B.5737	SCREW TE 10X85 5737
1648	VITE TE 10X75 5739 Z.B. TUT.FI	SCREW TE 10X75 5739 Z.B. TUT.FI
2227	RONDELLA 16x30 Z.B.	WASHER 16x30 ZINC PLATED
2290	DADO BLOK M16 DIN 985 Z.B.	SELF-LOCKING NUT M16 DIN 985 ZINC PLATED
2539	VITE TE 16X90 5737 ZINCATA	GALVANIZED SCREW TE 19X90 5737
3395	GANCIO SOLLEV.COMPLETO MK8-120 HCS	COMPLETE LIFTING HOOK HCS
4572	GANCIO SOLLEV. HCS (ATTAC.SX)	LIFTING HOOK HCS LEFT BRACKET
4573	GANCIO SOLLEV. HCS (ATTAC.DX)	LIFTING HOOK HCS RIGHT BRACKET
4574	GANCIO SOLLEV. HCS (SUPERIORE)	LIFTING HOOK HCS

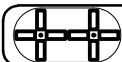

MK8-120 HCS



MK10-120 HCS

TABLE
TAVOLA **M**

ELECTRICAL SCHEME 12V FOR DOUBLE

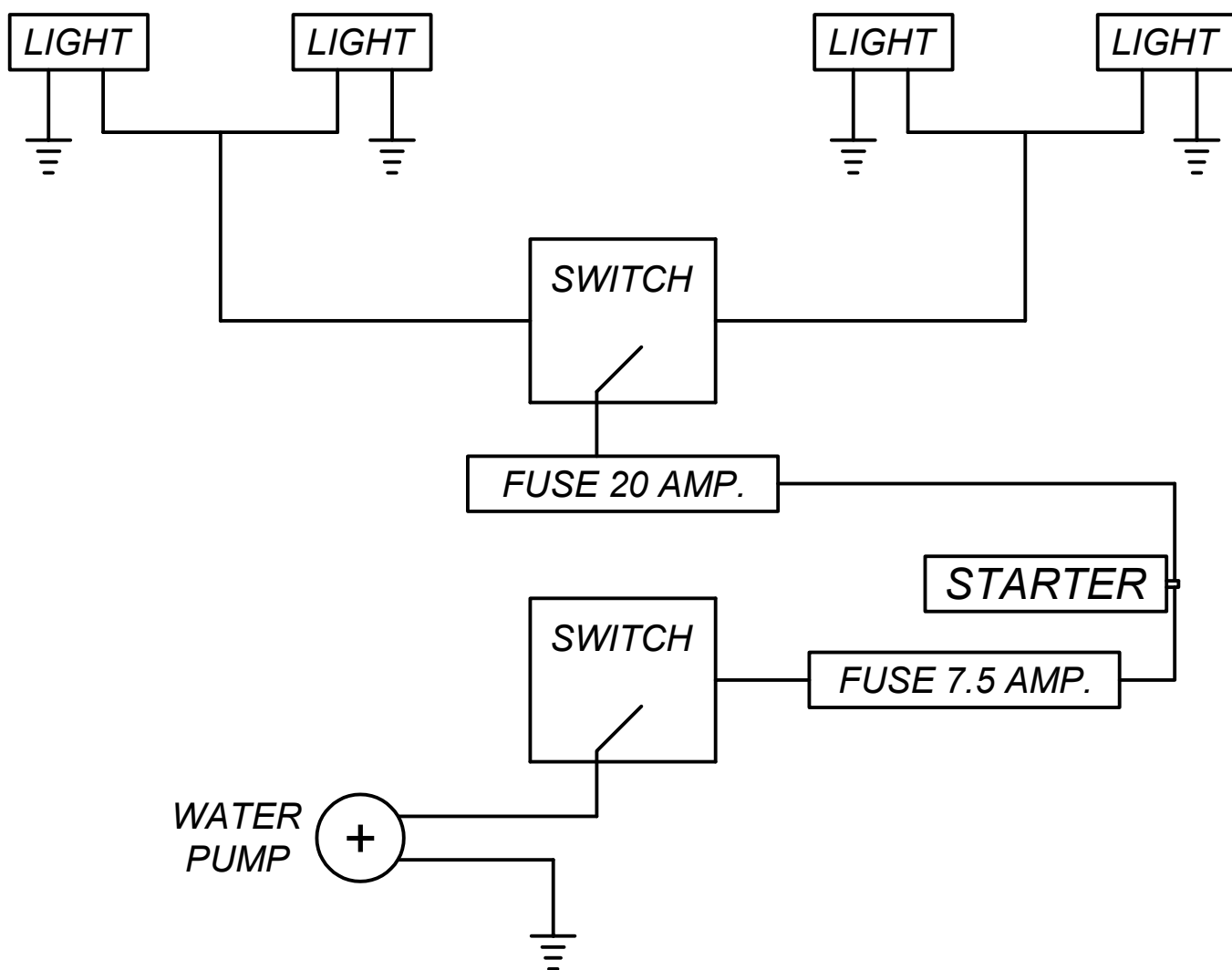

SWITCH SEAT

EMERGENCY

