

BARIKELL

SPARE PART LIST MANUAL *MANUALE ELENCO PARTI DI RICAMBIO*

RIDE ON TROWEL MK8-90 GASOLINE
FRATTAZZATRICE MK8-90 BENZINA

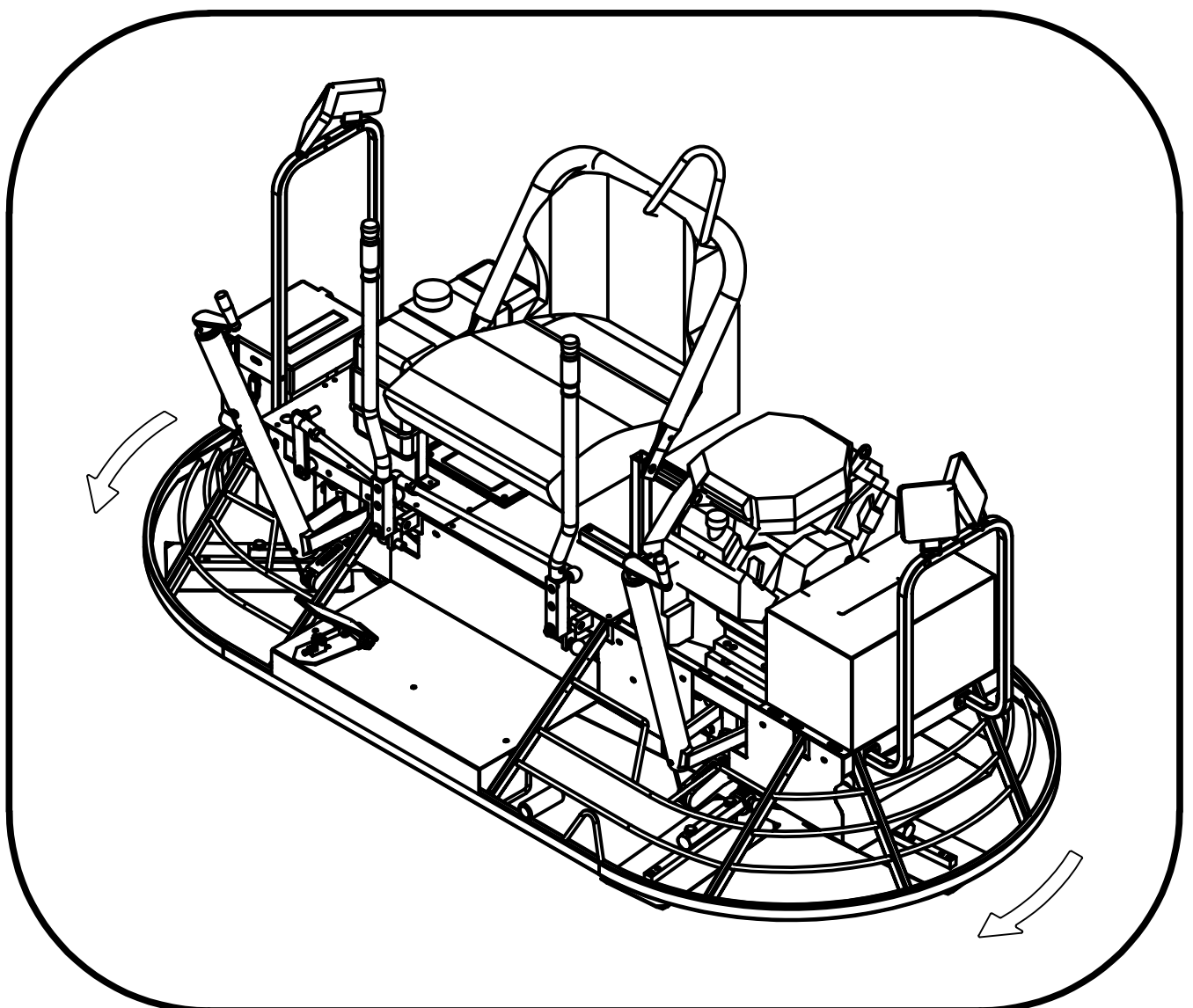

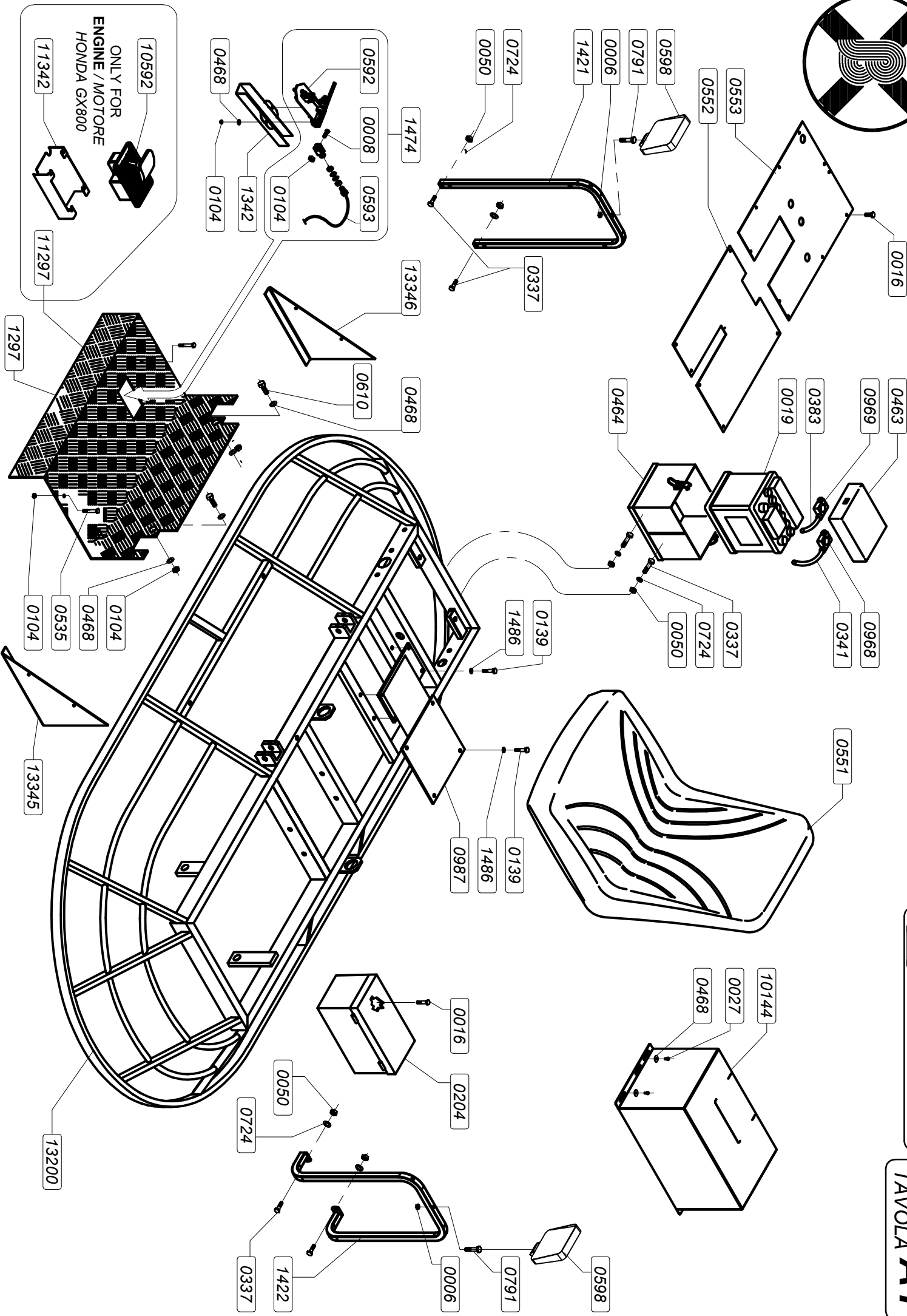
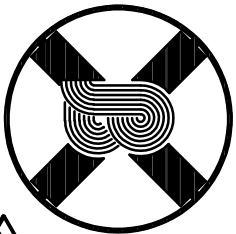

ONLY FOR
ENGINE / MOTORE
HONDA GX800



MK8-90

**TABLE
TAVOLA
A1**

COD.	DESCRIZIONE (I)	DESCRIPTION (GB)
0006	DADO M8 UNI 5588 Z.B.	NUT M8 UNI 5588 ZINC PLATED
0008	VITE TE 6x16 5739 Z.B.	SCREW HEX HEAD 6x16 5739 ZINC PLATED
0016	VITE AUTOFIL.4,8X16 UNI 6950	SELF-TAPPING SCREW 4,8X16 UNI 6950
0019	BATTERIA 45AH - 54534 (+ Dx)	BATTERY 45AH - 54534 (+ Dx)
0027	VITE TCCE 5x10 5931 Z.B.	SCREW TCCE 5x10 5931
0050	DADO BLOKM8 DIN 985 Z.B.	SELF-LOCKING NUT M8 DIN 985 Z. P.
0104	DADO BLOKM6 -DIN 985 Z.B.	BLOK NUT M6 985
0139	VITE TE 8x16 UNI 5739 Z.B.	HEXAGONAL SCREW 8X16
0204	CASSETTA PORTA ATTREZZI	TOOL BOX
0337	VITE TE 8x40 5737 Z.B.	SCREW HEX HEAD 8x40 5737 ZINC PLATED
0341	CAVO POSITIVO X DOPPIE L=2000	BATTERY CABLE POSITIVE L=2000
0383	CAVO NEGAT.C/MORS.BAT.27160	NEGATIVE LEAD
0463	COPERCHIO BATTERIA IN PLASTICA	BATTERY COVER
0464	SCATOLA PORTABATTERIA	BATTERY BOX OL90/120 MK8-90
0468	RONDELLA 6x18X1,5 Z.B.	WASHER 6x18X1,5 ZINC PLATED
0471	VITE TE 6x65 5737 Z.B.	SCREW HEX HEAD 6x65 5737 ZINC PLATED
0535	VITE TE 6x35 UNI 5737 Z.B.	SCREW TE 6x35 UNI 5737 Z.B.
0551	SEDILE PS40 OL90/120/MK8-90/120	SEAT PS40 OL120/MK8-90/120
0552	PEDANA SUPERIORE SX MK8-90/OL120	UPPER REAR PLATFORM MK890/OL120
0553	PEDANA SUPERIORE DX MK8-90/OL120	UPPER FRONT PLATFORM MK8-90/OL120
0592	PEDALE ACCELERATORE RIF.30511	ACCELERATOR PEDAL RIF.30511
0593	FILO ACCELERATORE PER PEDALE ***	ACCELERATOR WIRE FOR PEDAL
0598	FARO LED	LED HEADLIGHT
0610	VITE TE 6x40 UNI 5737 Z.B.	SCREW HEX HEAD 6x40 UNI 5737 ZINC P.
0724	RONDELLA 8x24 - ZINCATA BIANCA	WASHER 8x24 - ZINC PLATED
0790	VITE TE 6x20 5739 Z.B.	SCREW TE 6x20 5739
0791	VITE TE 8x45 UNI 5737 Z.B.	SCREW TE 8x45 UNI 5737
0968	MORSETTO "+"PER BATTERIA 27150	CLAMP "+" FOR BATTERY 27150
0969	MORSETTO "-" PER BATTERIA 27160	CLAMP "-" FOR BATTERY 27160
0987	PIANTONE SEDILE OL90/120 MK8-75/90/120	SEAT SUPPORT OL90/120 MK8-75/90/120
10144	CARTER FRIZIONE	CLUTCH GUARD
10592	PEDALE ACCELERATORE PER INIEZIONE	ACCELERATOR PEDAL FOR IGNITION ENGINE
11297	PEDANA APPOGGIA PIEDI MK8-90 PEDALE ELETTRONICO	FOOT BOARD MK8-90 FOR ELECTRONIC PEDAL
11342	CARTER PROTEZ. PEDALE ACCELERATORE ELETTRONICO	PROTECTION FOR ELECTRONIC ACCELERATOR PEDAL
1297	PEDANA APPOGGIO PIEDI MK8-90	FOOT BOARD MK8-90
13200	TELAIO PROT.MK8-90	FRAME PROTECTION MK8-90
1342	CARTER PROTEZ.PEDALE ACCEL.	PROTECTION FOR ACCELERATOR PEDAL
1421	STAFFA PORTAFARO DX	RIGHT HEADLIGHT SUPPORT
1422	STAFFA PORTAFARO SX	LEFT HEADLIGHT SUPPORT
1474	GRUPPO ACCELERATORE	ACCELERATOR GROUP
1486	RONDELLA ZIGRINATA D.8 Z.B.	WASHER D.8 ZINC PLATED

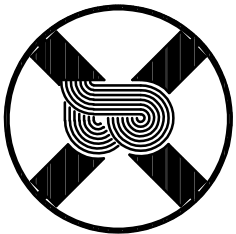

HYDRAULIC TROLLEY
CARRELLO IDRAULICO

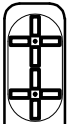

MK8-90



MK10-90

TABLE
TAVOLA
A2

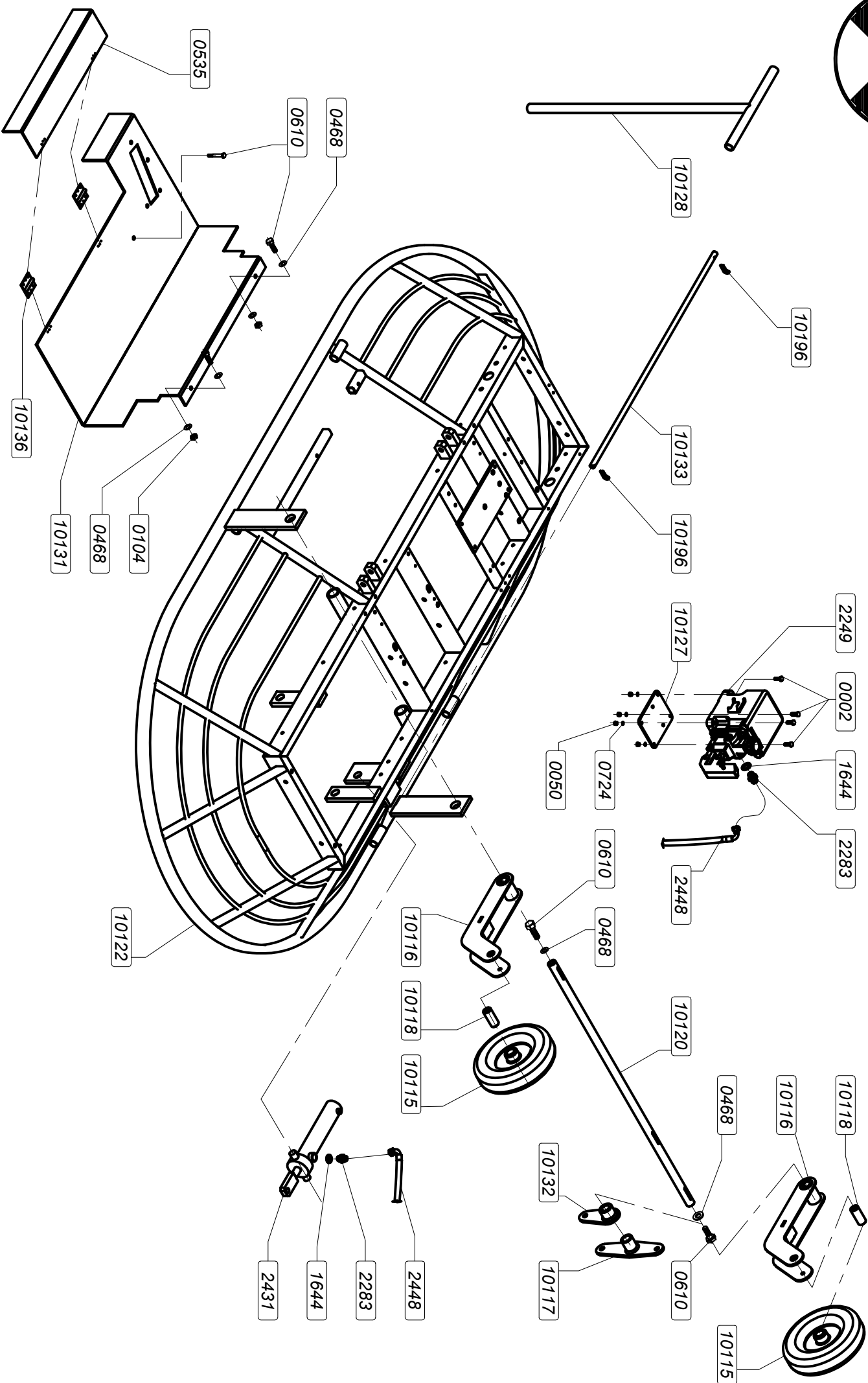

COD.	DESCRIZIONE (I)	DESCRIPTION (GB)
0002	VITE TE 8x35 UNI 5737 Z.B.	HEXAGONAL SCREW 8X35
0050	DADO BLOKM8 DIN 985 Z.B.	SELF-LOCKING NUT M8 DIN 985 ZINC PLATED
0104	DADO BLOKM6 -DIN 985 Z.B.	BLOK NUT M6 985
0468	RONDELLA 6x18X1,5 Z.B.	WASHER 6x18X1,5 ZINC PLATED
0471	VITE TE 6x65 5737 Z.B.	SCREW HEX HEAD 6x65 5737 ZINC PLATED
0610	VITE TE 6x40 UNI 5737 Z.B.	SCREW HEX HEAD 6x40 UNI 5737 ZINC P.
0724	RONDELLA 8x24 - ZINCATA BIANCA	WASHER 8x24 - ZINC PLATED
10115	RUOTA CARRELLO SERIE LN D.250X60 F.25X60	TROLLEY WHEEL LN D.250X60 F.25X60
10116	SUPPORTO RUOTE Z.BIANCO X CARR.IDRAULICO	WHEELS BRACKET
10117	ATTACCO CILINDRO FISSO Z. BIAN	FIXED CYLINDER BRACKET
10118	BOCCOLA D.25-12.5 L= 62 Z.B.X CAR.IDRAUL	BUSH D=25-12.5 L=62
10120	ALBERO D.25 L= 1020 Z.BIA.X CAR.IDR.	HYDR. TROLLEY SHAFT D=25 L=1020
10122	TELAIO PROT.MK8-90 PER CARRELLO HCS	FRAME PROTECTION MK8-90 HYDR. TROLLEY
10127	SUPPORTO POMPA X CARRELLO IDRAULICO Z.B.	PUMP BRACKET
10128	MANICO X CARRELLO IDRAULICO Z.B.	HANDLE FOR HYDR. TROLLEY
10131	PEDANA APPOG.PIEDI MK8-90 X TELAI C/CARR	FOOT BOARD MK8-90
10132	ATTACCO CILINDRO MOBILE	MOBILE CYLINDER BRACKET
10133	ALBERO D.15 L=900 PER CARRELLO IDRAULICO	HYDR. TROLLEY SHAFT D=15 L=900
10136	CERNIERA QUADRA ZINCATA 70MM	SQUARE HINGE 70 MM
10196	COPIGLIA A "R" DIAM. 4 ZNB UNI 4042	COTTER PIN "R" D=4 UNI4042
1486	RONDELLA ZIGRINATA D.8 Z.B.	WASHER D.8 ZINC PLATED
1621	RONDELLA RAME 17X22X1,5	WASHPLAIN 17X23X1,5
2249	POMPA IDRAULICA MANUALE CON SERBAT. 1 LT	MANUAL HYDRAULIC PUMP
2283	NIPLES M-M 3/8"	NIPPLE 3/8"
2431	CILINDRO C/BASCUL.FLOOR 10/20/	CYLINDER WITH SWING DEVICE
2448	TUBO FLEX R7 3/8"F.90 3/8"F.90	FLEX PIPE R7 3/8"F.90 3/8"F.90 L=550mm

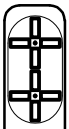
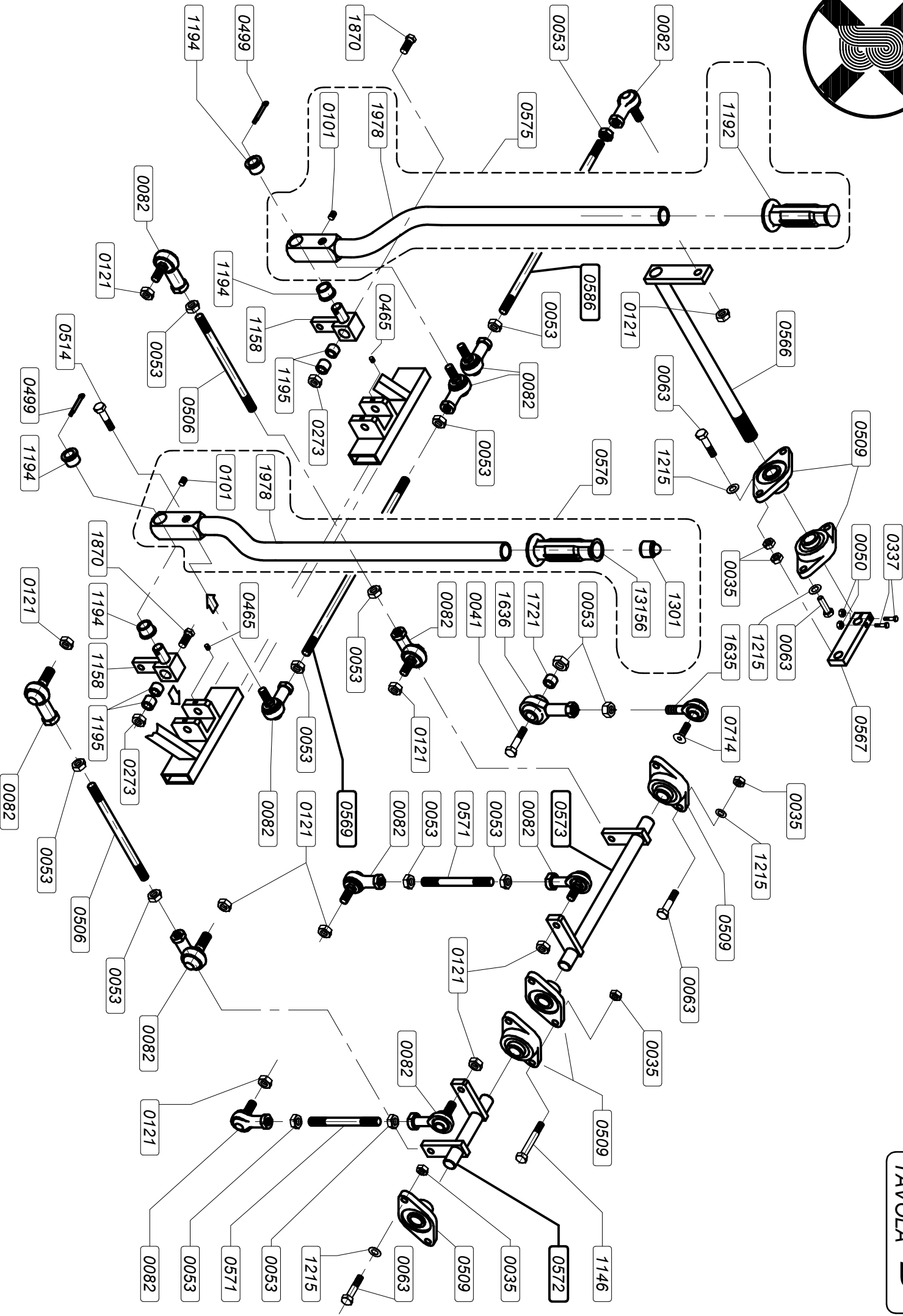
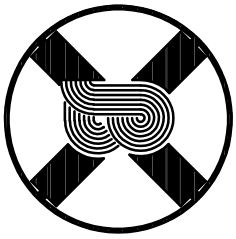

MK8-90

**TABLE
TAVOLA**

B

COD.	DESCRIZIONE (I)	DESCRIPTION (GB)
0035	DADO BLOKM10 -985 - Z.B.	SELF-LOCKING NUT M10 -985 ZINC PLATED
0041	VITE TE 14X70 UNI5737 Z.B.10.9	SCREW TE 14X70 5737
0050	DADO BLOKM8 DIN 985 Z.B.	SELF-LOCKING NUT M8 DIN 985 ZINC PLATED
0053	DADO M14 BASSO UNI 5589 Z.B.	NUT M14 UNI 5589 ZINC PLATED
0063	VITE TE 10x50 -5737 - Z.B.	SCREW TE 10x50 -5737 ZINC PLATED
0082	SNODO AD ANGOLO LHSA 14 C/TESTA CARBONIT	BALL ARTICULATION LHSA 14 C/HEAD CARBONIT
0101	INGRASSATORE M6X1	GREASE FITTING M6X1
0121	DADO BLOKM14 BASSO 7474 Z.B	SELF-LOCKING NUT M14 BASSO 7474 ZINC PLATED
0273	DADO BLOK M12 985 ZB	SELF-LOCKING NUT M12 985 ZINC PLATED
0337	VITE TE 8x40 5737 Z.B.	SCREW HEX HEAD 8x40 5737 ZINC PLATED
0465	GRANO M6x8 -5927	DOWEL M6x8 -5927
0499	SPINA ELASTICA 6x30	UNIVERSAL PIN 6x30
0506	TIRANTE M14 L=185 Z.B.x doppie	TIEROD M14 L=185 ZINC PLATED
0509	SUPPORTO UCFL 204 FK	SUPPORT UCFL 204 FK
0514	VITE TE 14x40 5739 ZB	SCREW TE 14X40 5739
0566	LEVA TRASL.C/ALB.OL120/MK8-120	TRANSLATION LEVER OL120/MK8-120
0567	LEVA TRASLAZIONE LATER. OL 120	TRANSLATION LEVER. OL 120
0569	PRIGIONIERO M14 L=360 Z.B.MK8-90/MK8-120	STUD M14 L=360 ZINC PLATED
0571	TIRANTE M14 L=95 OL90/120 MK8-75/90/120	TIEROD M14 L=95 OL90/120 MK8-75/90/120
0572	COPPIA LEVA DX L=170 OL120/MK8-90	RH LEVER PAIR L=170 OL120/MK8-90
0573	COPPIA LEVA SX L=355 OL120/MK8-90	LH LEVER PAIR
0575	COMPLESSIVO ASTA GUIDA DESTRA	RH ASSEMBLED ARM FOR DOUBLE MACHINES
0576	COMPLESSIVO ASTA GUIDA SINISTRA	LH ASSEMBLED ARM FOR DOUBLE MACHINES
0586	PRIGIONIERO M14 L=195 Z.B.OL120/MK8-90	STUD M14 L=195
0714	VITE VSP 14x45 - 5933 Z.B.	SCREW C.F.H. 14x45 - 5933 ZINC PLATED
1146	VITE TE 10x60 - 5737 ZINC.	SCREW HEX HEAD 10X60 - 5737 ZINC PLATED
1158	BLOCCHETTO PER ASTA GUIDA PER DOPPIE	BRACKET FOR DRIVING ROD
1192	MANOPOLA CHIUSA D.27 SENZA	KNOB CLOSE D.27
1194	BUSSOLA D.26-22-15 L=16	SLEEVE D.26-22-15 L=16
1195	BUSSOLA 18-12 L=12 DIN 179/C	SLEEVE 18-12 L=12 DIN 179/C
1215	RONDELLA PIANA 10x30 Z.B.	WASHER 10x30 ZINC PLATED
1301	INTERRUTTORE ACQUA DOPPIE	WATER SWITCH
1635	TERMIN.SNODO MARCA "SB" JAM 14	TERMIN.ARTICULATION "SB" JAM 14
1636	TERMIN.SNODO MARCA "SB" JAF 14	TERMIN.ARTICULATION "SB" JAF 14
1721	DISTANZIALE D.21,3-14,9 L=23	SPACER D.21,3-14,9 L=23
1870	VITE M12 CH19 L=70 Z.B. CARBONITRURATA	SCREW M12 CH19 L=70 ZINC PLATED CARBONITRIDING
1978	ASTA GUIDA PER DOPPIE	DRIVING ROD
13156	MANOPOLA D.27 SENZA PARAMANI FORO D.18	KNOB D.27

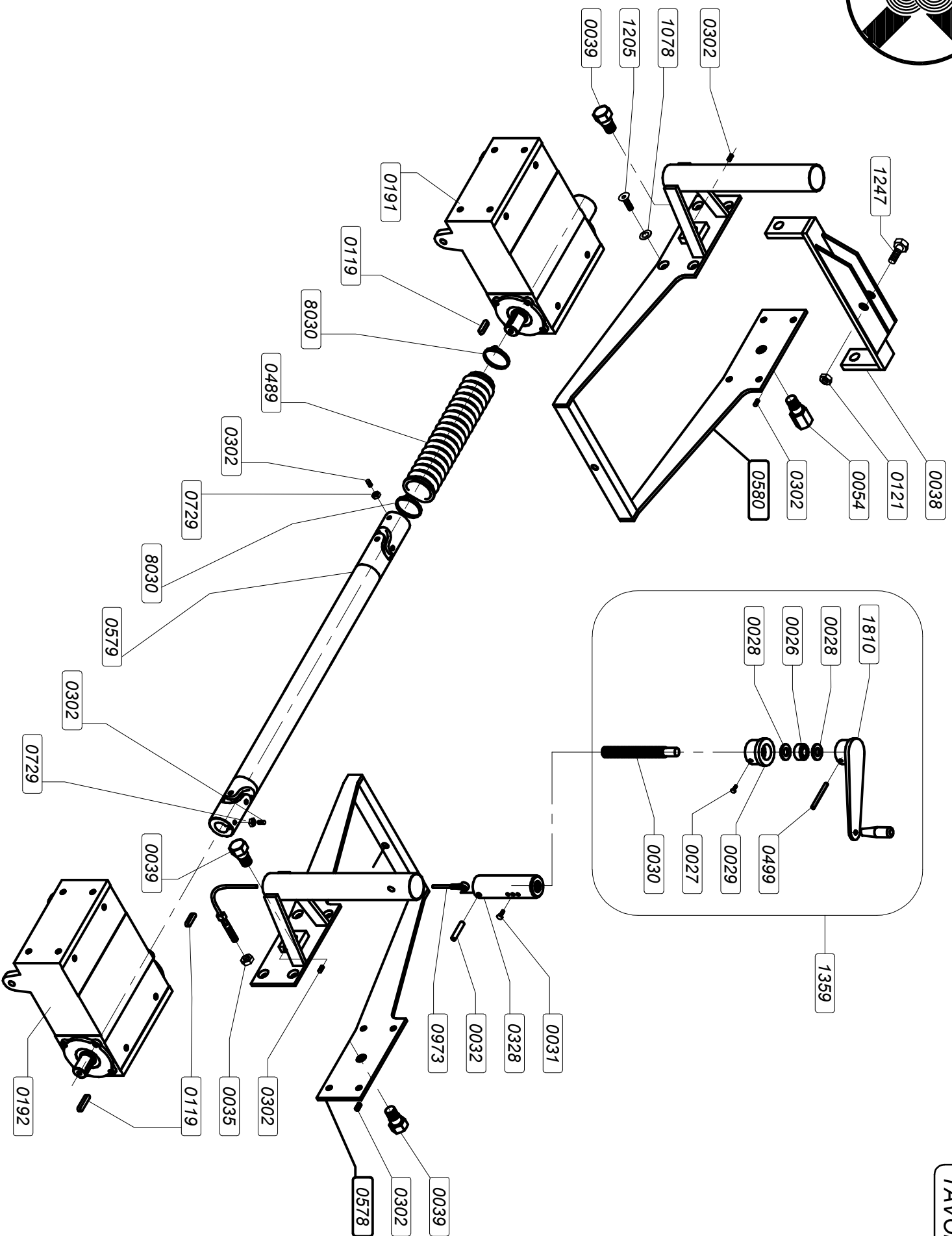

MK8-90

**TABLE
TAVOLA
C**

COD.	DESCRIZIONE (I)	DESCRIPTION (GB)
0026	CUSCINETTO REGGISPINTA AXK1528	BEARING THRUST AXK1528
0027	VITE TCCE 5x10 5931 Z.B.	SCREW TCCE 5x10 5931 ZINC PLATED
0028	RALLA AS 1528	BOLSTER AS 1528
0029	ANELLO PORTACUSC.REGGISPINTA	RING BEARING THRUST
0030	PERNO FILETTATO x REGIST. PALE	PIN THREAD FOR REGIS. TOOLHOLDER
0031	VITE TCCE 6x10 5931 Z.B.	SCREW TCCE 6x10 5931 ZINC PLATED
0032	SPINA CILINDRICA 8x40 UNI 1707	UNIVERSAL PIN 8x40 UNI 1707
0035	DADO BLOKM10 -985 - Z.B.	SELF-LOCKING NUT M10 -985 ZINC PLATED
0038	PONTE BASCULANTE	SWINGING SUPPORT
0039	PERNO BASCULANTE M18 L=45 CH27Z.B.	PIN M18 L=45 CH27Z.B.
0054	VITE BLOCCAGGIO M18-14 L=60 CH27ZB	LOCK SCREW M18-14 L=60 CH27ZB
0119	CHIAVETTA 8x7x30 - 6604A	KEY 8x7x30 - 6604A
0121	DADO BLOKM14 BASSO 7474 Z.B	SELF-LOCKING NUT M14 7474 ZINC PLATED
0191	RIDUTTORE COMPLETO DX V100	GEAR BOX DX V100
0192	RIDUTTORE COMPLETO SX V100	GEAR BOX SX V100
0302	GRANO M6x16 - 5927	DOWEL M6x16 - 5927
0328	ATTACCO SUPERIORE x CAVO DI REGISTRO	SUP.ATTACHMENT FOR REGISTER CABLE
0489	CUFFIA PROTEZIONE CARDANO	DUST BOOT GIMBAL
0499	SPINA ELASTICA 6x30	UNIVERSAL PIN 6x30
0578	BASCULANTE SX OL120/MK8-90/120	GUIDE UNIT LH FLANGE OL120/MK890/120
0579	ALBERO CARD. OL120/MK8-90-120	DRIVE SHAFT OL120/MK8-90-120
0580	BASCULANTE DX OL120/MK8-90-120	GUIDE UNIT RH FLANGE
0729	DADO M6 5589 BASSO Z.B.	LOW NUT M6 5589
0973	CAVO D.4X49X535 C/TERM.	CABLE D.4X49X535
1078	RONDELLA ZIGRIN.D10 ZINC.B.	WASHER D10 ZINC PLATED
1205	VITE TE 10x20 UNI 5739 Z.B.	SCREW TE 10x20 UNI 5739 ZINC PLATED
1247	VITE TE 14X75 UNI5737 Z.B.	SCREW TE 14X75 UNI5737 ZINC PLATED
1359	COMPLESSIVO SOLLEVAMENTO PALE	BLADE LIFTER UNIT W/CRANK
1810	LEVA ZINC. CON MANIGLIA NERA M8	LEVER WITH BLACK KNOB M8
8030	FASCETTA	HOSE CLAMP BLACK B4-190C 4,8X200

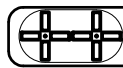

MK8-90

**TABLE
TAVOLA D**

**RIGHT ROTOR
ROTORE DESTRO**

**BATTERY SIDE
LATO BATTERIA**

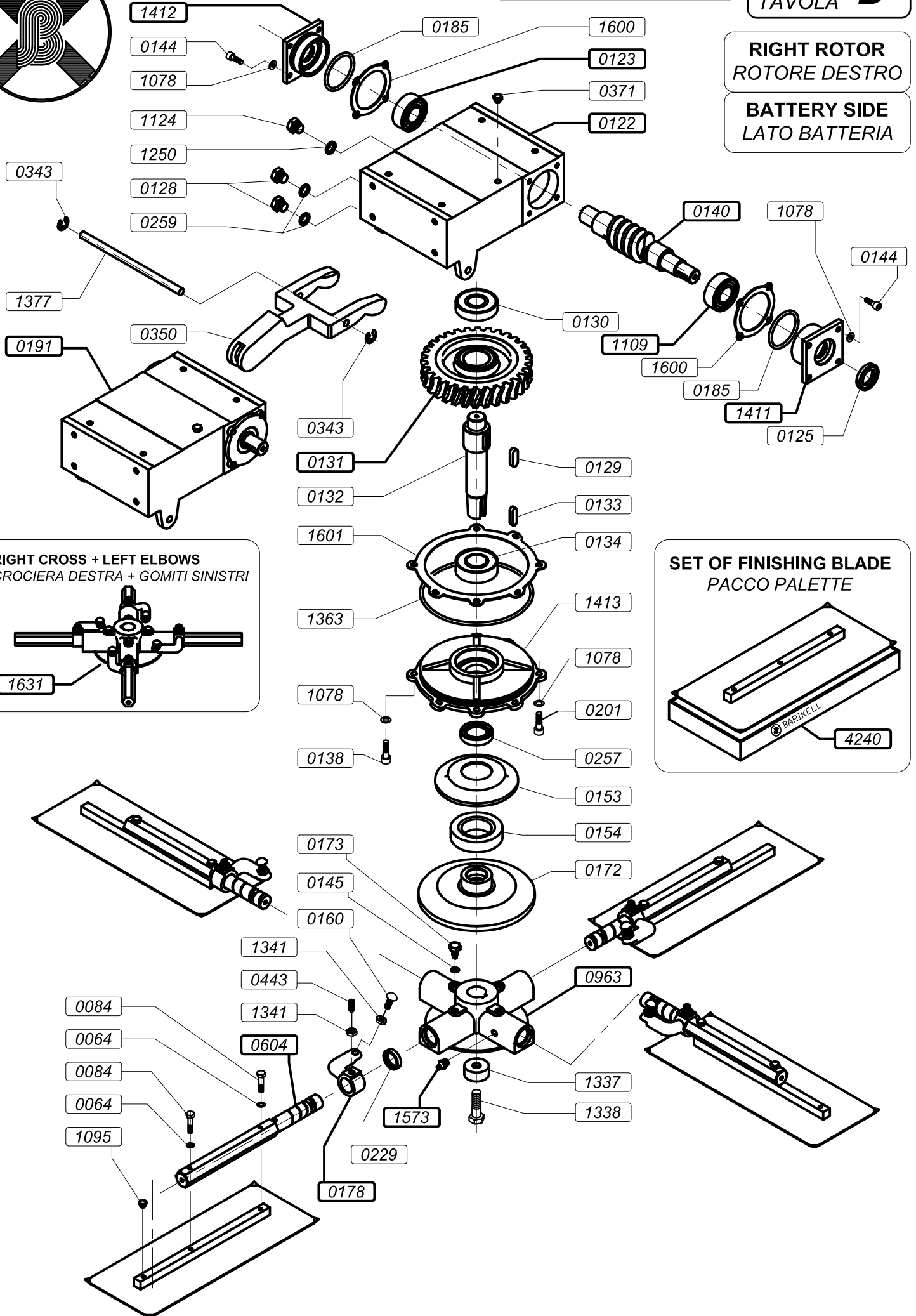

**RIGHT CROSS + LEFT ELBOWS
CROCIERA DESTRA + GOMITI SINISTRI**

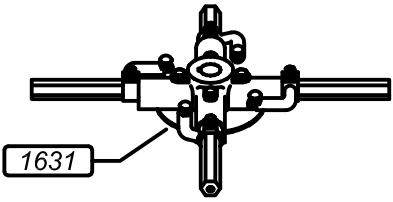

**SET OF FINISHING BLADE
PACCO PALETTE**

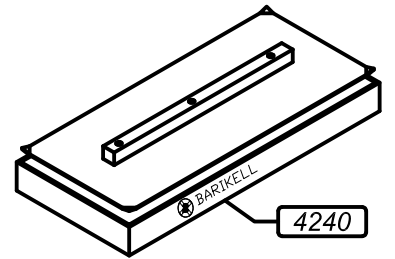

COD.	DESCRIZIONE (I)	DESCRIPTION (GB)
0064	RONDELLA GROWER 10 - Z.B.	WASHER 10 ZINC PLATED
0084	VITE TE 10x45 UNI 5737 Z.B.	SCREW HEX HEAD 10x45 UNI 5737 Z.P.
0122	SCATOLA DX RIDUTTORE V100	GEAR BOX DX V100
0123	CUSCINETTO CONICO 30206 V100 CX	TAPER BEARING 30206 V100 CX
0125	PARAOLIO DOPPIA TENUTA 30X47X7	OILSEAL DOUBLE SEALING 30X47X7
0128	TAPPO SCARICO OLIO 3/8" GAS ZB	PLUG OIL 3/8" GAS ZINC PLATED
0129	CHIAVETTA 12x8x35 - 6604A	KEY 12x8x35 - 6604A
0130	CUSCINETTO CONICO 30306 CX	TAPER BEARING 30306 CX
0131	CORONA DENTATA DX V100	RH CROWN GEAR V100
0132	ALBERO LENTO V100	SHAFT V100
0133	CHIAVETTA 10x8x35 - 6604A	KEY 10x8x35 - 6604A
0134	CUSCINETTO CONICO 32207 V100 CX	TAPER BEARING 32207 V100 CX
0138	VITE TCCE 10x20 Z.B. UNI 5931	SCREW TCCE 10x20 G.W. UNI 5931
0140	VITE SENZA FINE DX V100	RH WORM SCREW V100
0144	VITE TE 10x25 5739 Z.B.	SCREW HEX HEAD 10x25 5739 ZINC PLATED
0145	RONDELLA PIANA 10x21 6592 Z.B.	WASHER 10x21 6592 ZINC PLATED
0153	COPRICUSCINETTO 4-90/4-120	COVER BEARING 4-90/4-120
0154	CUSCINETTO REGGISPINTA BCA2256	BEARING BCA2256
0160	VITE TTDE 10X30 UNI 5731 SENZA	SCREW TTDE 10X30 UNI 5731
0172	CAMPANA REGIS.PALE 4-120/OL90	UPPER HEAD TOOL HOLDER 4-120/OL90
0173	VITE BLOC.BRAC.P.PALE 4-90/120	SCREW FIX TOOLHOLDER 4-90/120
0178	GOMITO SX GHISA D.28	BEND SX CART IRON D.28
0185	OR 3262 NBR PER V100	OR 3262 NBR PER V100
0191	RIDUTTORE COMPLETO DX V100	RH COMPLETE GEAR BOX V100
0201	VITE VSP 10x20 5933 Z.B.	SCREW VSP 10x20 5933 ZINC PLATED
0229	O-RING D.28 SEZ.1,5	O-RING D.28 SEZ.1,5
0257	PARAOLIO DOP.TENUTA 35X55X10	OIL SEAL 35X55X10
0259	RONDELLA ALL. 17x23x1.5 X RID.	WASHER ALL. 17x23x1.5
0343	ANELLO RADIALE DIAM.10	SEAL DIAM.10
0350	FORCELLA COMANDO PALE D.11	YOKE CONTROL TOOLHOLDER D.11
0371	TAPPO SFIATO 1/8"+ RONDELLA IN RAME	BREATHER PLUG 1/8"+ COPPER WASHER
0443	GRANO M10x20 UNI 5927	DOWEL M10x20 UNI 5927
0604	BRACCIO P.PALE MK8-90 D.28	BEND FOR TOOL HOLDER MK8-90
0963	CROCERA D.28 OL120/MK8-120/MK8-90	SPIDER D.28 OL120/MK8-120/MK8-90
1078	RONDELLA ZIGRIN.D10 ZINC.B.	WASHER D10 ZINC PLATED
1095	TAPPO POLIETILENE NEUTRO D.9mm	PLUG POLYETHYLENE D.9mm
1109	CUSCI.CONICO 30206 "NSK" V100	COVER BEARING 30206 "NSK" V100
1124	INDICAT.LIV.OLIO 3/4" VETRO	LEVEL INDICATOR OIL 3/4" GLASS
1250	RONDELLA ALL.27X33X1,5 3/4"	WASHER ALL.27X33X1,5 3/4"
1337	RONDELLA BLOCC. CROCERA X DOPP	WASHER FOR LOCK SPIDER
1338	VITE TE 12x1.5x35 UNI5740 10.9 z.b.	SCREW HEX HEAD 12x1.5x35 UNI5740 Z.P.
1341	DADO M10 5589 BASSO GREZZO	NUT M10 5589
1363	OR 4725 183,75X3,53 SH70 NBR	OR 4725 183,75X3,53 SH70 NBR
1377	PERNO FORCEL.D.11 L=219 V100	PIN FOR YOKE D.11 L=219 V100
1411	COPERCHIO LATERALE APERTO V100	LATERAL OPENED COVER V100
1412	COPERCHIO LAT.CHIUSO V100	LATERAL CLOSED COVER V100
1413	COPERCHIO INF. V100	INFERIOR COVER V100

COD.	DESCRIZIONE (I)	DESCRIPTION (GB)
1573	INGRASSATORE M8X1.25 2802	GREASE FITTING M8X1.25 2802
1600	GUARNIZIONE LATERALE V100	LATERAL SEAL V100
1601	GUARNIZIONE INFERIORE V100	INFERIOR SEAL V100
1631	CROCIERA COMPL.DX MK8-90 C/INGR	SPIDER RIGHT MK8-90
4240	PACCO PALETTE MK8-90	SET OF FINISHING BLADES MK8-90

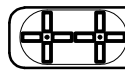

MK8-90

**TABLE
TAVOLA E**

**LEFT ROTOR
ROTORE SINISTRO**

**ENGINE SIDE
LATO MOTORE**

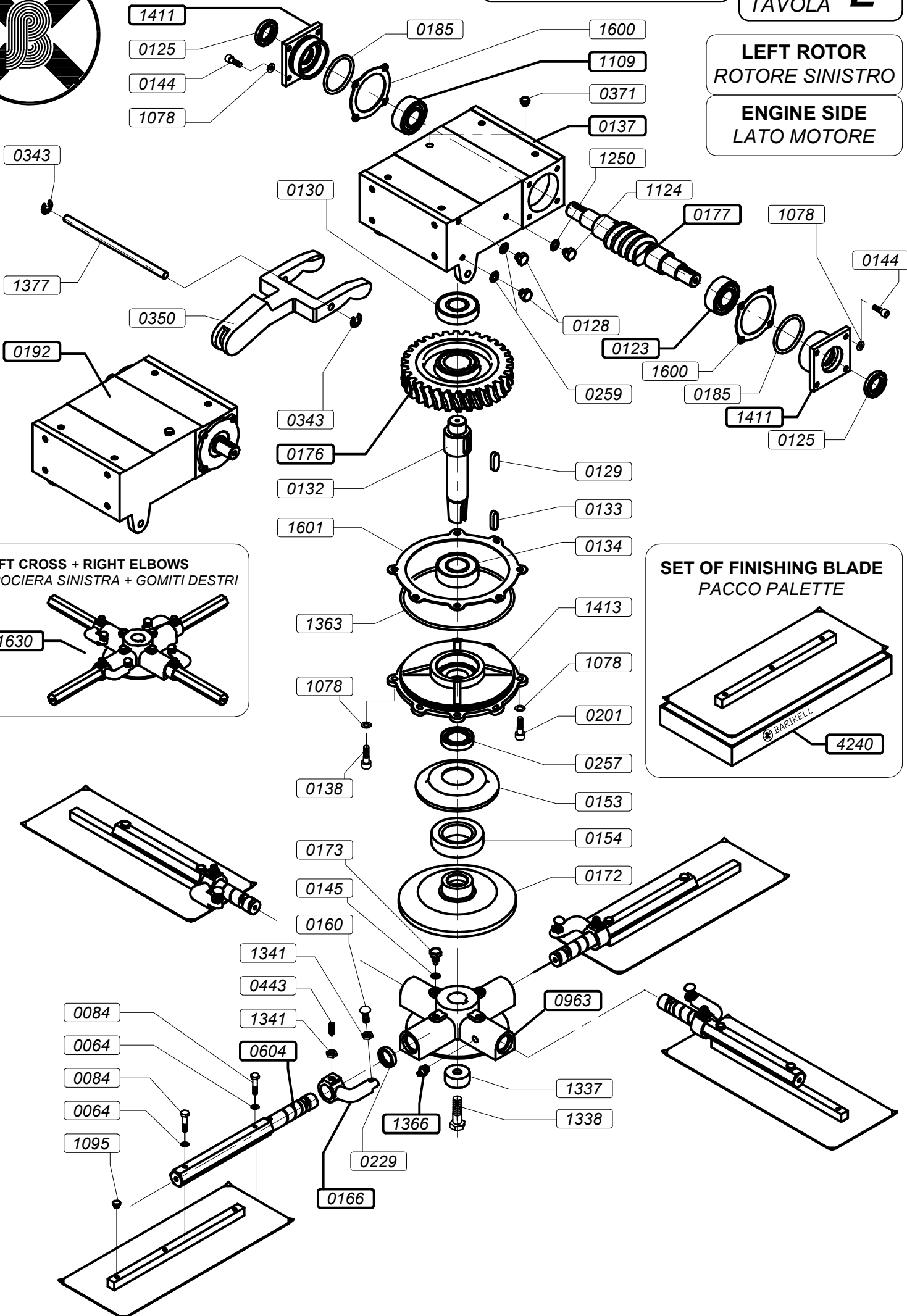

**LEFT CROSS + RIGHT ELBOWS
CROCIERA SINISTRA + GOMITI DESTRI**

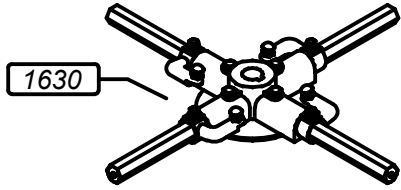

**SET OF FINISHING BLADE
PACCO PALETTE**

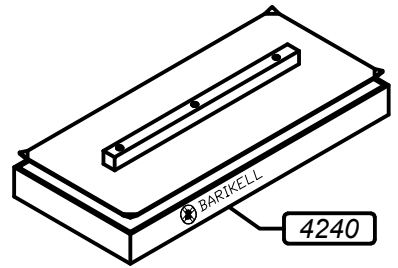

COD.	DESCRIZIONE (I)	DESCRIPTION (GB)
0064	RONDELLA GROWER 10 - Z.B.	WASHER 10 ZINC PLATED
0084	VITE TE 10x45 UNI 5737 Z.B.	SCREW HEX HEAD 10x45 UNI 5737 ZINC PLATED
0123	CUSCINETTO CONICO 30206 V100 CX	TAPER BEARING 30206 V100 CX
0125	PARAOLIO DOPPIA TENUITA 30X47X7	OILSEAL DOUBLE SEALING 30X47X7
0128	TAPPO SCARICO OLIO 3/8" GAS ZB	PLUG OIL 3/8" GAS ZINC PLATED
0129	CHIAVETTA12x8x35 - 6604A	KEY 12x8x35 - 6604A
0130	CUSCINETTO CONICO 30306 CX	TAPER BEARING 30306 CX
0132	ALBERO LENTO V100	SHAFT V100
0133	CHIAVETTA10x8x35 - 6604A	KEY 10x8x35 - 6604A
0134	CUSCINETTO CONICO 32207 V100 CX	TAPER BEARING 32207 V100 CX
0137	SCATOLA SX RIDUTTORE V100	LEFT GEARBOX V100
0138	VITE TCCE 10x20 Z.B. UNI 5931	SCREW TCCE 10x20 ZINC PLATED UNI 5931
0144	VITE TE 10x25 5739 Z.B.	SCREW HEX HEAD 10x25 5739 ZINC PLATED
0145	RONDELLA PIANA 10x21 6592 Z.B.	WASHER 10x21 6592 ZINC PLATED
0153	COPRICUSCINETTO 4-90/4-120	COVER BEARING 4-90/4-120
0154	CUSCINETTO REGGISPINTA BCA2256	BEARING BCA2256
0160	VITE TTDE10X30 UNI 5731 SENZA	SCREW TTDE10X30 UNI 5731
0166	GOMITO DX GHISA D28	RH ELBOW D28 MK8-90/120/OL120
0172	CAMPANA REGIS.PALE 4-120/OL90	UPPER HEAD TOOL HOLDER 4-120/OL90
0173	VITE BLOC.BRAC.P.PALE 4-90/120	SCREW FIX TOOLHOLDER 4-90/120
0176	CORONA DENTATA SX V100	LH CROWN GEAR V100
0177	VITE SENZA FINE SX V100	LH WORMSCREW V100
0185	OR 3262 NBR PER V100	OR 3262 NBR PER V100
0192	RIDUTTORE COMPLETO SX V100	GEAR BOX SX V100
0201	VITE VSP 10x20 5933 Z.B.	SCREW VSP 10x20 5933 ZINC PLATED
0229	OR D.28 SEZ.1,5 PER CROC.	O-RING D.28 SEZ.1,5
0257	PARAOLIO DOP.TENUITA 35X55X10	OIL SEAL 35X55X10
0259	RONDELLA ALL. 17x23x1.5 X RID.	WASHER ALL. 17x23x1.5
0343	ANELLO RADIALE DIAM.10	SEAL DIAM.10
0350	FORCELLA COMANDO PALE D.11	YOKE CONTROL TOOLHOLDER D.11
0371	TAPPO SFIATO 1/8"+ RONDELLA IN RAME	BREATHER PLUG 1/8"+ COPPER WASHER
0443	GRANO M10x20 UNI 5927	DOWEL M10x20 UNI 5927
0604	BRACCIO P.PALE MK8-90 D.28	BEND FOR TOOL HOLDER MK8-90
0963	CROCERA D.28 OL120/MK8-120/MK8-90	SPIDER D.28 OL120/MK8-120/MK8-90
1078	RONDELLA ZIGRIN.D10 ZINC.B.	WASHER D10 ZINC PLATED
1095	TAPPO POLIETILENE NEUTRO D.9mm	PLUG POLYETHYLENE D.9mm
1109	CUSCI.CONICO 30206 "NSK" V100	COVER BEARING 30206 "NSK" V100
1124	INDICAT.LIV.OLIO 3/4" VETRO	LEVEL INDICATOR OIL 3/4" GLASS
1250	RONDELLA ALL.27X33X1,5 3/4"	WASHER ALL.27X33X1,5 3/4"
1337	RONDELLA BLOCC. CROCERA X DOPP	WASHER FOR LOCK SPIDER
1338	VITE TE 12x1.5x35 UNI5740 10.9 z.b.	SCREW HEX HEAD 12x1.5x35 UNI5740 ZINC PLATED
1341	DADO M10 5589 BASSO GREZZO	NUT M10 5589
1363	OR 4725 183,75X3,53 SH70 NBR	OR 4725 183,75X3,53 SH70 NBR
1366	INGRASSATORE M8X1,25	GREASE FITTING M8X1,25
1377	PERNO FORCEL.D.11 L=219 V100	PIN FOR YOKE D.11 L=219 V100
1411	COPERCHIO LATERALE APERTO V100	SIDE COVER V100
1413	COPERCHIO INF. V100	INFERIOR COVER V100
1600	GUARNIZIONE LATERALE V100	LATERAL SEAL V100
1601	GUARNIZIONE INFERIORE V100	INFERIOR SEAL V100
1630	CROCIERA COMPL.SX MK8-90 C/INGR	SPIDER LEFT MK8-90
4240	PACCO PALETTE MK8-90	SET OF FINISHING BLADES MK8-90



WATER AND FUEL SYSTEM
IMPIANTO ACQUA E BENZINA

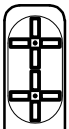

MK8-90

TABLE
TAVOLA
F1

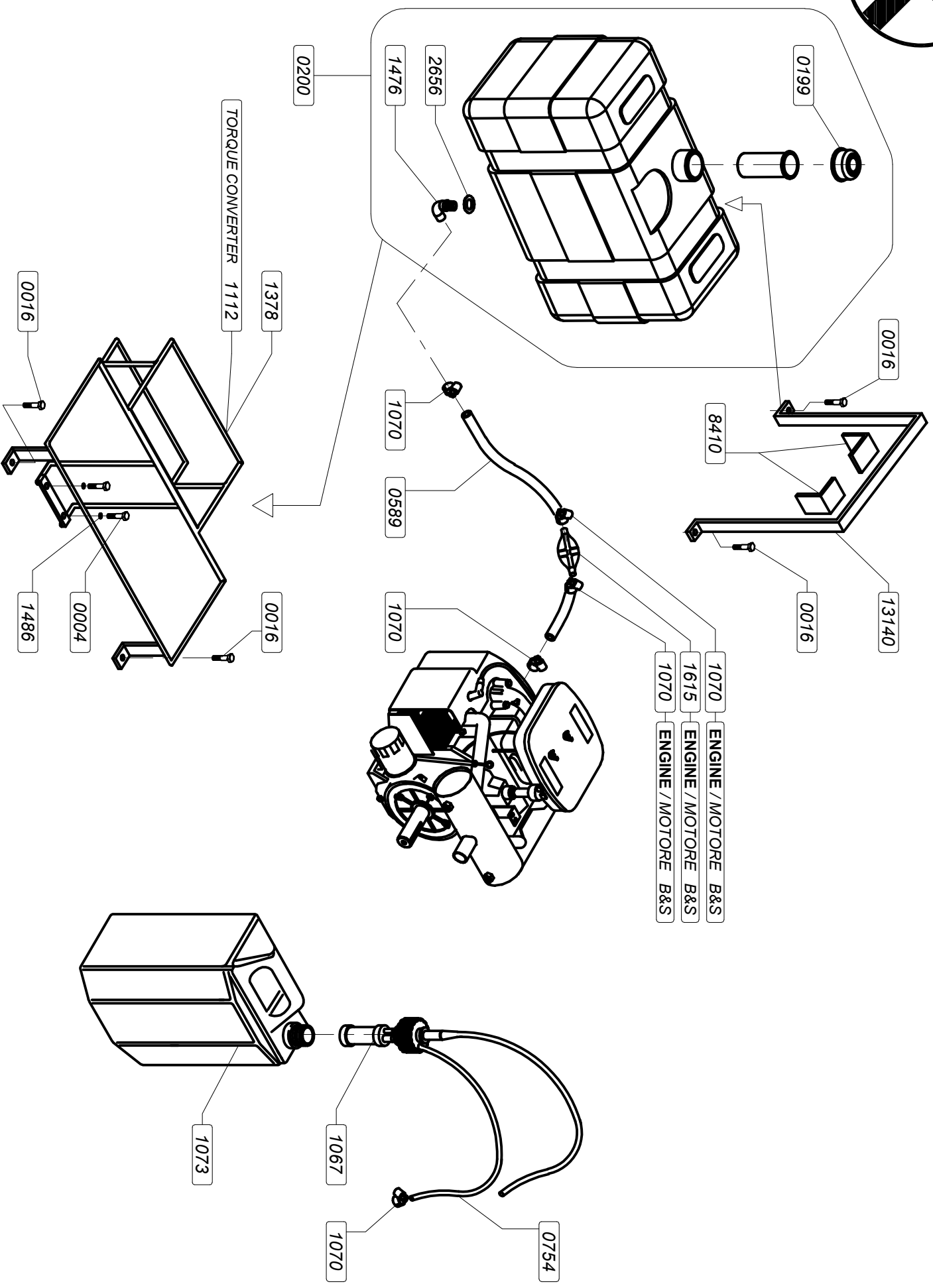

COD.	DESCRIZIONE (I)	DESCRIPTION (GB)
0004	VITE TE 8x20 UNI 5739 Z.B.	HEX HEAD BOLT 8x20 UNI 5739 ZINC PLATED
0016	VITE AUTOFIL.4,8X16 UNI 6950	SELF-TAPPING SCREW 4,8X16 UNI 6950
0199	TAPPO SERBATOIO	TANK CAP
0200	SERBATOIO BENZINA C/RACCORDO 90° S/GUARN	GAS TANK WITH FITTING 90°
0589	TUBO CARBOPRESS NV 8X14 ECO	PIPE CARBOPRESS NV 8X14 ECO
0754	TUBO ARMORVIN HNA 10 RIF. RPQ0191	PIPE ARMORVIN HNA 10 RIF. RPQ0191
1067	POMPA ACQUA 12.V+CONNETTORE	WATER PUMP 12.V+CONNECTOR
1070	FASCETTA VELOX 5 TUBO 8-19	HOSE CLAMP VELOX 5 TUBO 8-19
1073	TANICA ACQUA LT.15 CCC0206	WATER TANK LT.15 CCC0206
1112	PORTA TANICA T.C.	TANK HOLDER T.C.
1378	PORTA TANICA	TANK HOLDER
1476	RACCORDO PER SERBATOIO	FITTING FOR TANK
1486	RONDELLA ZIGRINATA D.8 Z.B.	WASHER D.8 ZINC PLATED
1615	POMPETTA ASPIRAZIONE BENZINA HCS	FUEL SUCTION PUMP HCS
2656	RONDELLA FERRO-GOMMA D12	WASHER IRON-RUBBER D12
8410	ANGOLARE PLASTICA 45X45	PLASTIC ANGLE 45X45
13140	STAFFA FISSAGGIO SERB.BENZINA DOPPIE	CLAMP FUEL TANK

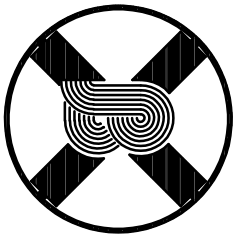

EPA WATER AND FUEL SYSTEM IMPIANTO ACQUA E BENZINA



MK8-90

**TABLE F2
TAVOLA**

ENGINE / MOTORE ROBIN	COD. 3245
ENGINE / MOTORE KOHLER	COD. 3255 - 3257
ENGINE / MOTORE HONDA	COD. 3260 - 3265
ENGINE / MOTORE B&S	COD. 3271 - 3272 - 3273

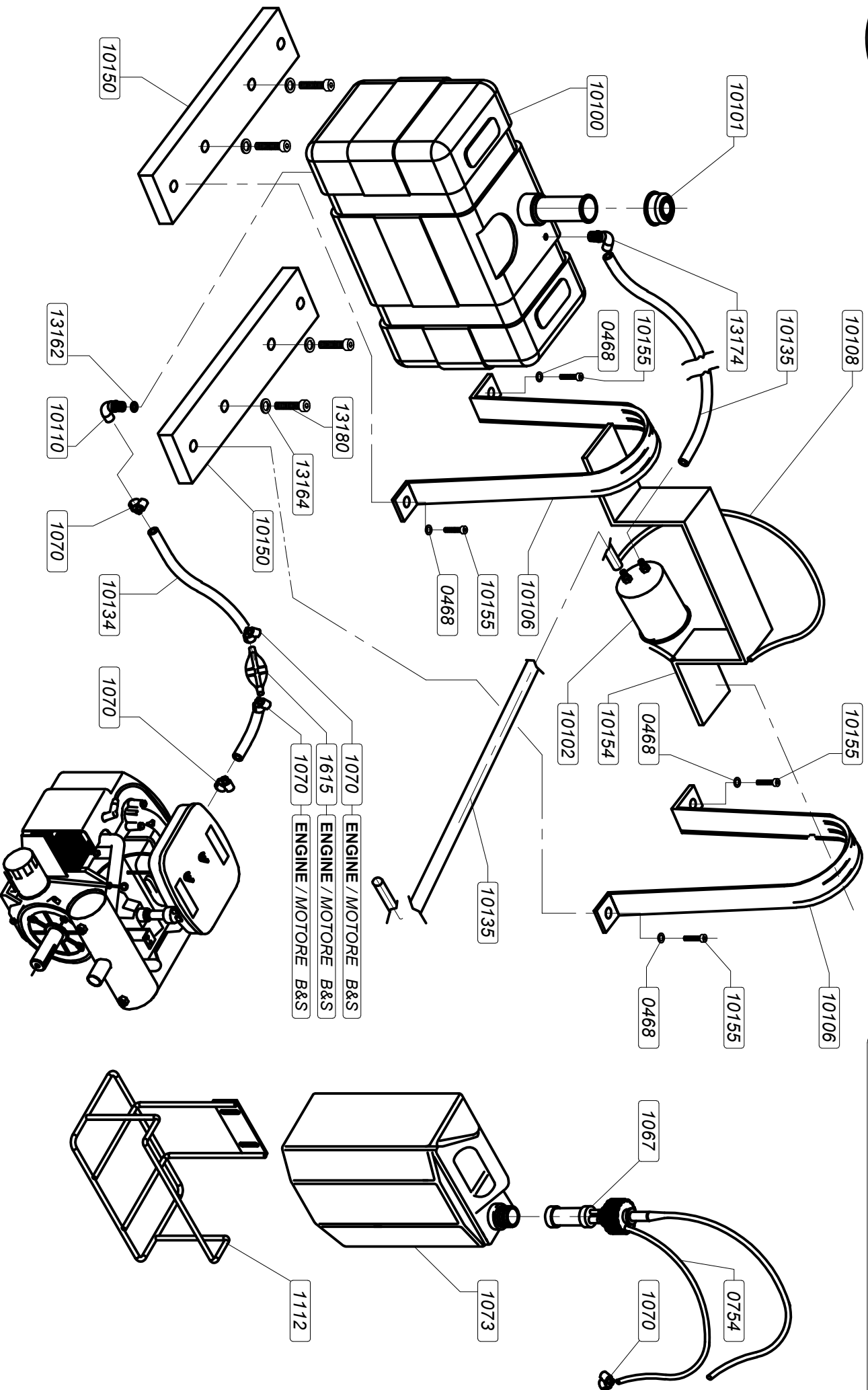

COD.	DESCRIZIONE (I)	DESCRIPTION (GB)
0468	RONDELLA 6x18X1,5 Z.B.	WASHER 6x18X1,5 ZINC PLATED
0754	TUBO ARMORVIN HNA 10 RIF. RPQ0191	PIPE ARMORVIN HNA 10 RIF. RPQ0191
1067	POMPA ACQUA 12.V+CONNETTORE	WATER PUMP 12.V+CONNECTOR
1070	FASCETTA VELOX 5 TUBO 8-19	HOSE CLAMP VELOX 5 TUBO 8-19
1073	TANICA ACQUA LT.15 CCC0206	WATER TANK LT.15 CCC0206
1112	PORTA TANICA MK8-90 HCS/OL-120 HCS	SUPPORT FUEL TANK MK8-90 HCS/OL-120 HCS
1615	POMPETTA ASPIRAZIONE BENZINA HCS	FUEL SUCTION PUMP HCS
10100	TANICA BENZINA CARB-EPA 5 GALLONI	FUEL TANK CARB-EPA 5 GALLONS
10101	TAPPO 2-1/4" TANICA BENZ. NORMA CARB-EPA	PLUG 2-1/4" FUEL TANK
10102	CARBON CANISTER CARB-EPA 400 cc	CARBON CANISTER CARB-EPA 400 cc
10106	CINGHIA FERRO TANICA BENZ.NORMA CARB-EPA	IRON BELT FOR TANK FUEL CARB-EPA
10108	FASCETTA SUPP. CARBON CANISTER	HOSE CLAMP CARBON CANISTER
10110	PORTAGOMMA 90° TUBO D. 6 FIL. 1/8"	FITTING 90° PIPE D. 6 FIL. 1/8"
10134	TUBO BENZINA TANICA CARB-EPA RT. 50ft	TANK FUEL PIPE CARB-EPA RT. DA 50ft
10135	TUBO FUMI A NORMA CARB-EPA RT. DA 50ft.	PIPE SMOKE CARB-EPA RT. DA 50ft.
10150	STAFFA SERB.BENZ.EPA	BRACKET TANK FUEL
10154	STAFFA ALLUMINIO CARB-EPA	ALUMINIUM BRACKET EPA
10155	VITE TCCE 6x30 UNI 5931 Z.B.	SOCKET HEAD CAP SCREW 6X30 - 5931 ZINC PLATED
13162	RONDELLA FERRO-GOMMA 1/8"	WASHER IRON-RUBBER 1/8"
13164	RONDELLA ZIGRIN.D.6 ZINC.B.-SCHNORR-	WASHER D.6 G.W. -SCHNORR-
13174	RACCORDO 90° PER SERBATOIO	CONNECTOR 90° FOR TANK
13180	VITE TCCE 6x16 UNI 7984 Z.B.TESTA RIBAS	SCREW 6x16 UNI 7984 ZINC PLATED

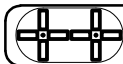

MK8-90

**TABLE
TAVOLA G1**

- 4385 ENGINE / MOTORE KOHLER CH730 23.5HP
- 4391 ENGINE / MOTORE KOHLER CH742 25HP

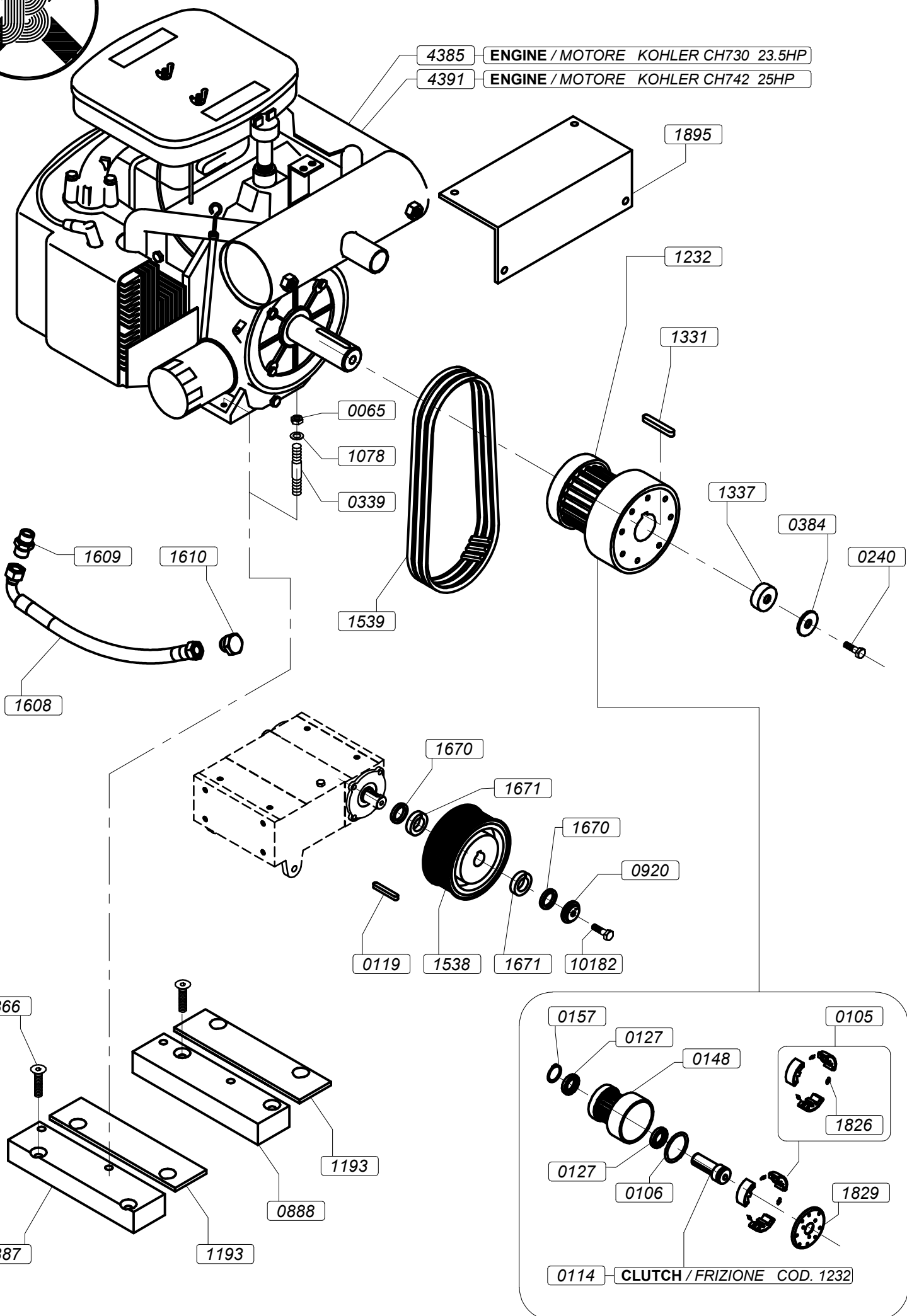

COD.	DESCRIZIONE (I)	DESCRIPTION (GB)
0065	DADO M10 5588 Z.B.	NUT M10 5588 ZINC PLATED
0105	SERIE MASSE FRIZIONI DENTATE HTD PER COD. 1232/33/34 RIF.MF621800332	FLYWEIGHT CLUTCH HTD RIF.MF621800332
0106	ANELLO X FRIZIONE DENTATA COD.1232/33/34	JUNT RING CLUTCH COD.1232/33/34
0114	ALBERO TRASCIN.D.28.57 X FRIZ.COD.1232	CLUTCH SHAFT D.28.57 COD.1232
0119	CHIAVETTA 8x7x30 - 6604A	SMALL KEY 8X7X30 6604A
0127	CUSCINETTO 6010 2RS X FRIZIONE DENTATA	BEARING 6010 2RS FOR TOOTHED CLUTCH
0148	CAMPANA Ø 138 X FRIZ.DENT COD.1232/33/34	UPPER HEAD Ø 138 FOR TOOTHED CLUTCH COD.1232/33/34
0157	SEEGER "E" 50 UNI 7435-75 X FR.DENTATA	SEEGER "E" 50 UNI 7435-75
0240	VITE TE UNF 7/16x2"1/4	HEX HEAD BOLT UNF 7/16x2"1/4
0339	PRIGIONIERO M10 L=40 DIN 939 Z.B.	STUD M10 L=40 DIN 939 ZINC PLATED
0384	RONDELLA PIANA D.12 6592 ZB	WASHER D.12 6592 ZINC PLATED
0887	STAFFA MOT.ANTER.KOHLER 25/27	ANTERIOR SUPPORT KHOLER ENGINE 25/27
0888	STAFFA MOT.POSTER.KOHLER 25/27	REAR SUPPORT KHOLER ENGINE 25/27
0920	RONDELLA FISSAGGIO	FIXING WASHER
1078	RONDELLA ZIGRIN.D10 ZINC.B.	WASHER D10 ZINC PLATED
1193	STAFFA MOTORE ANT./POST.KOHL 50X15 L=180	FRONT/REAR SUPPORT KOHL 50X15 L=180
1232	FRIZIONE DENTATA D.28.575 MK8-90/120/OL90/120	TOOTHED CLUTCH D.28.575
1331	CHIAVETTA 38,1x6,3x6,3 B.& S	KEY 38,1x6,3x6,3 B.& S
1337	RONDELLA BLOCCAGGIO	LOCKING WASHER
1538	PULEGGIA Z 56X50 M8 D.25 H7 CH8	PULLEY Z 56X50 M8 D.25 H7 CH8
1539	CINGHIA DENTATA HTD 8M 50X880 HCS	TOOTHED BELT HTD 8M 50X880 HCS
1608	TUBO B.P.R6 3/8"-3/8"F90^ 3/8"	PIPE B.P.R6 3/8"-3/8"F90^ 3/8"
1609	NIPLES GAS NPT-CILINDRICO 3/8"	NIPPLES GAS NPT 3/8"
1610	TAPPO TESTA ESAGONALE GAS 3/8"	HEX HEAD CAP GAS 3/8"
1670	BOCCOLA 35X5 FORO D.26	BUSHING 35X5 HOLE D.26
1671	BOCCOLA 35X10 FORO D.26	BUSHING 35X10 FORO D.26
1826	MOLLA FRIZIONE BARIKELL 115E DENTATA COD. 1232/33/34 -RIF. ML.62180040-	SPRING FOR CLUTCH BARIKELL 115E
1829	COPERCHIO FRIZIO.BARIKELL 115 E DENTATA	CLUTCH COVER BARIKELL 115
1866	VITE VSP 10X55 Z.B. 5933	H.S.C.H. SCREW 10X55 UNI 5933 ZINC PLATED
1895	PROTEZIONE MARMITTA	MUFFLER PROTECTION
4385	MOTORE KOHLER 23.5HP CH730-3201	ENGINE KOHLER 23.5HP CH730-3201
4391	MOTORE KOHLER 25HP CH742-3103	ENGINE KOHLER 25HP CH742-3103
10182	VITE TE 8x30 10.9 5739 ZINC.B.	SOCKET HEAD CAP SCREW 8x30 10.9 5739 ZINC PLATED

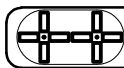

MK8-90

TABLE TAVOLA G2

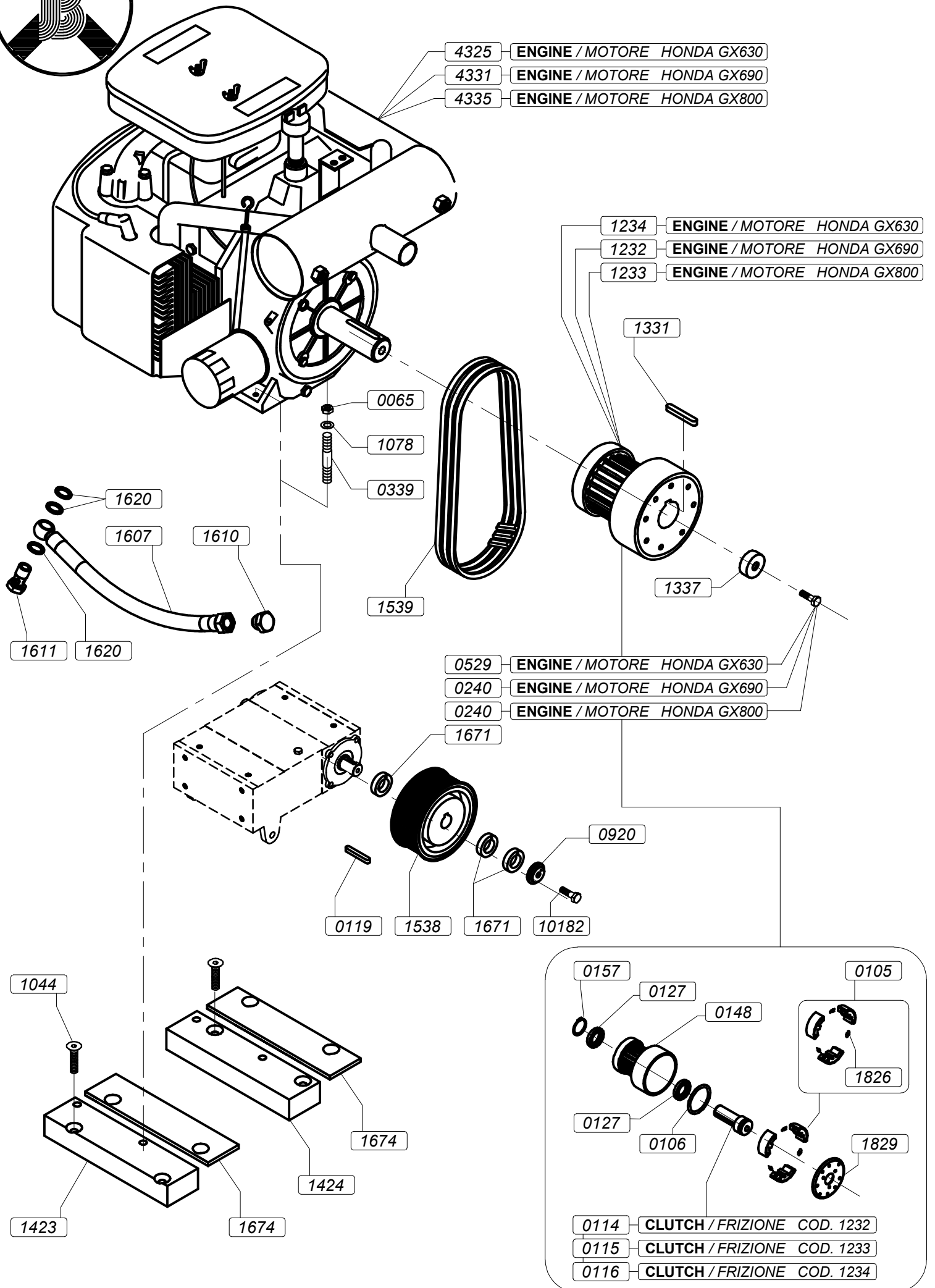

COD.	DESCRIZIONE (I)	DESCRIPTION (GB)
0065	DADO M10 5588 Z.B.	NUT M10 5588 ZINC PLATED
0105	SERIE MASSE FRIZIONI DENTATE HTD PER COD. 1232/33/34 RIF.MF621800332	FLYWEIGHT CLUTCH HTD RIF.MF621800332
0106	ANELLO X FRIZIONE DENTATA COD.1232/33/34	JUNT RING CLUTCH COD.1232/33/34
0114	ALBERO TRASCIN.D.28.57 X FRIZ.COD.1232	CLUTCH SHAFT D.28.57 COD.1232
0115	ALBERO TRASCIN.D.36.51 PER FRIZ.COD.1233	CLUTCH SHAFT D.36.51 X COD.1233
0116	ALBERO TRASCIN.D.25,4.51 X FRIZ.COD.1234	CLUTCH SHAFT D.25.4 COD.1234
0119	CHIAVETTA 8x7x30 - 6604A	SMALL KEY 8X7X30 6604A
0127	CUSCINETTO 6010 2RS X FRIZIONE DENTATA	BEARING 6010 2RS FOR TOOTHED CLUTCH
0148	CAMPANA Ø 138 X FRIZ.DENT COD.1232/33/34	UPPER HEAD Ø 138 FOR TOOTHED CLUTCH COD.1232/33/34
0157	SEEGER "E" 50 UNI 7435-75 X FR.DENTATA	SEEGER "E" 50 UNI 7435-75
0240	VITE TE UNF 7/16x2"1/4	HEX HEAD BOLT UNF 7/16x2"1/4
0339	PRIGIONIERO M10 L=40 DIN 939 Z.B.	STUD M10 L=40 DIN 939 ZINC PLATED
0529	VITE TE UNF 3/8x1"3/4	HEX HEAD BOLT UNF 3/8x1"3/4
0920	RONDELLA FISSAGGIO	FIXING WASHER
10182	VITE TE 8x30 10.9 5739 ZINC.B.	SOCKET HEAD CAP SCREW 8x30 10.9 5739 Z. P.
1044	VITE VSP 10x75 - 5933 ZINC.B.	SOCKET HEAD CAP SCREW 10x75 - 5933 Z. P.
1078	RONDELLA ZIGRIN.D10 ZINC.B.	WASHER D10 ZINC PLATED
1232	FRIZIONE DENTATA D.28.575	TOOTHED CLUTCH D.28.575
1233	FRIZIONE DENTATA D.36.5	CLUTCH MK8-120 D.1"7/16 36.5
1234	FRIZIONE DENTATA D.25,4 (1")	TOOTHED CLUTCH D.25,4 (1")
1331	CHIAVETTA 38,1x6,3x6,3 B.& S	KEY 38,1x6,3x6,3 B.& S
1337	RONDELLA BLOCCAGGIO	LOCKING WASHER
1423	STAFFA MOT. ANTERIORE	FRONT BRACKET ENGINE
1424	STAFFA MOT. POSTERIORE	REAR BRACKET ENGINE
1538	PULEGGIA Z 56X50 M8 D.25 H7 CH8	PULLEY Z 56X50 M8 D.25 H7 CH8
1539	CINGHIA DENTATA HTD 8M 50X880 HCS	TOOTHED BELT HTD 8M 50X880 HCS
1607	TUBO T.PLAS.R7 1/4" FD3/8"-1/4	PIPE R7 1/4" FD3/8"-1/4
1610	TAPPO TESTA ESAGONALE GAS 3/8"	HEX HEAD CAP GAS 3/8"
1611	BULLONE FORATO 14X1.5mm X TUBO SCAR.OLIO	BOLT HOLE 14X1.5mm FOR PIPE OIL
1620	RONDELLA RAME 14X20X1,5	WASHER COPPER 14X20X1,5
1671	BOCCOLA 40X10 FORO D.26	BUSHING 40X10 HOLE D.26
1674	SUPPORTO MOTORE UNIVERSALE X HONDA GX630 E GX690	UNIVERSAL BRACKET ENGINE FOR HONDA GX630 E GX690
1826	MOLLA PER FRIZIONE BARIKELL 115E -RIF. ML.62180040-	SPRING FOR CLUTCH BARIKELL 115E
1829	COPERCHIO FRIZ. BARIKELL 115 E DENTATA	CLUTCH COVER BARIKELL 115
4325	MOTORE HONDA GX630RH 20HP	ENGINE HONDA GX630RH 20HP
4331	MOTORE HONDA GX690 RH	ENGINE HONDA GX690 RH
4335	MOTORE HONDA GX800IRH	ENGINE HONDA GX800IRH

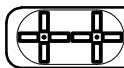

MK8-90

TABLE TAVOLA G3

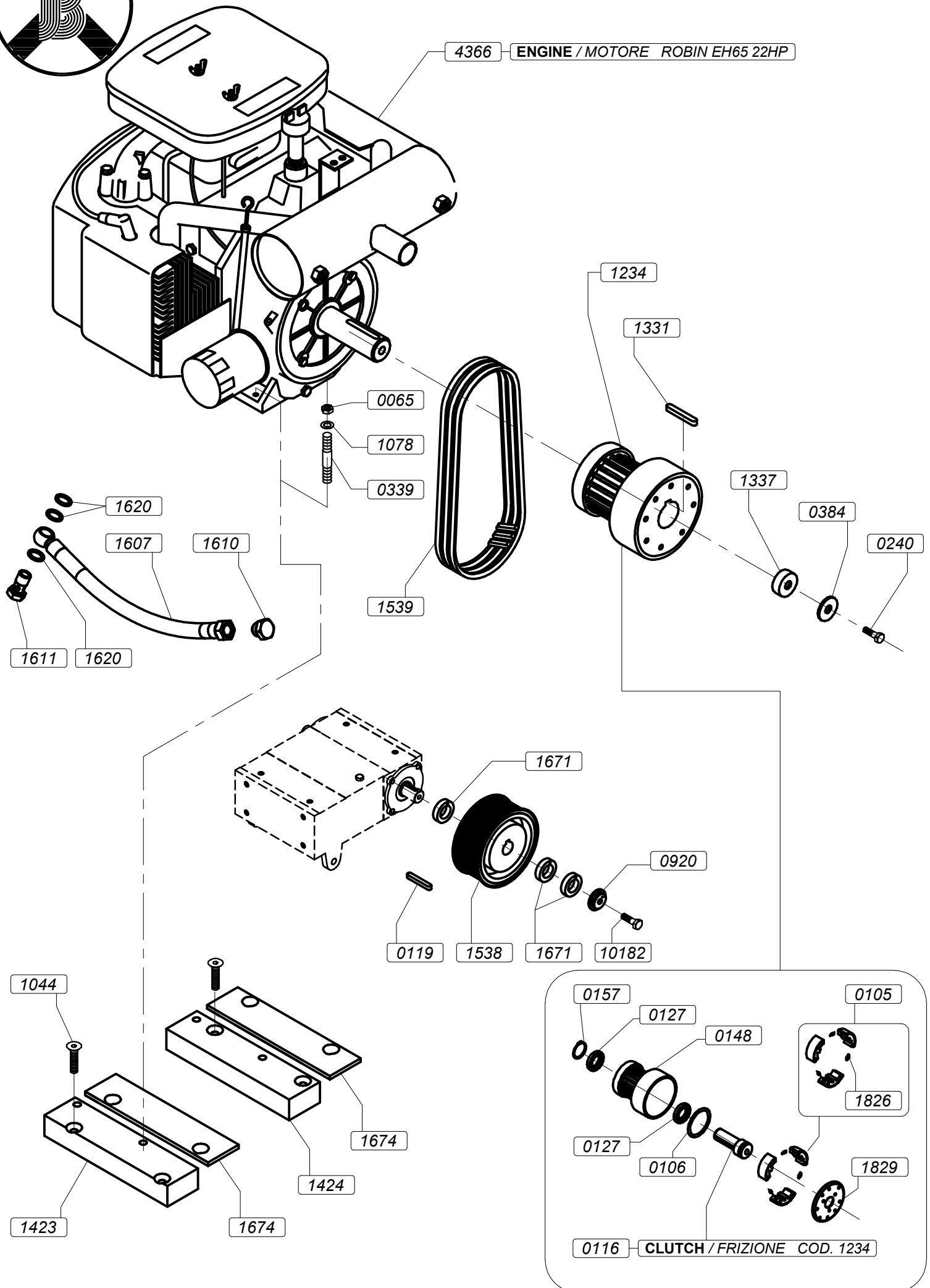

COD.	DESCRIZIONE (I)	DESCRIPTION (GB)
0065	DADO M10 5588 Z.B.	NUT M10 5588 ZINC PLATED
0105	SERIE MASSE FRIZIONI DENTATE HTD PER COD. 1232/33/34 RIF.MF621800332	FLYWEIGHT CLUTCH HTD RIF.MF621800332
0106	ANELLO X FRIZIONE DENTATA COD.1232/33/34	JUNT RING CLUTCH COD.1232/33/34
0116	ALBERO TRASCIN.D.25.4 X FRIZ.COD.1234	CLUTCH SHAFT D.25,4 X COD.1234
0119	CHIAVETTA 8x7x30 - 6604A	SMALL KEY 8X7X30 6604A
0127	CUSCINETTO 6010 2RS X FRIZIONE DENTATA	BEARING 6010 2RS FOR TOOTHED CLUTCH
0148	CAMPANA Ø 138 X FRIZ.DENT COD.1232/33/34	UPPER HEAD Ø 138 FOR TOOTHED CLUTCH COD.1232/33/34
0157	SEEGER "E" 50 UNI 7435-75 X FR.DENTATA	SEEGER "E" 50 UNI 7435-75
0240	VITE TE UNF 7/16x2"1/4	HEX HEAD BOLT UNF 7/16x2"1/4
0339	PRIGIONIERO M10 L=40 DIN 939 Z.B.	STUD M10 L=40 DIN 939 ZINC PLATED
0384	RONDELLA PIANA D.12 6592 ZB	WASHER D.12 6592 ZINC PLATED
0920	RONDELLA FISSAGGIO	FIXING WASHER
10182	VITE TE 8x30 10.9 5739 ZINC.B.	SOCKET HEAD CAP SCREW 8x30 10.9 5739 ZINC PLATED
1044	VITE VSP 10x75 - 5933 ZINC.B.	SOCKET HEAD CAP SCREW 10x75 - 5933 ZINC PLATED
1078	RONDELLA ZIGRIN.D10 ZINC.B.	WASHER D10 ZINC PLATED
1044	VITE VSP 10x75 - 5933 ZINC.B.	SOCKET HEAD CAP SCREW 10x75 - 5933 ZINC PLATED
1234	FRIZIONE DENTATA D.25,4 (1")	TOOTHED CLUTCH D.25,4 (1")
1331	CHIAVETTA 38,1x6,3x6,3 B.& S	KEY 38,1x6,3x6,3 B.& S
1337	RONDELLA BLOCCAGGIO	LOCKING WASHER
1423	STAFFA MOT. ANTERIORE	FRONT BRACKET ENGINE
1424	STAFFA MOT. POSTERIORE	REAR BRACKET ENGINE
1538	PULEGGIA Z 56X50 M8 D.25 H7 CH8	PULLEY Z 56X50 M8 D.25 H7 CH8
1539	CINGHIA DENTATA HTD 8M 50X880 HCS	TOOTHED BELT HTD 8M 50X880 HCS
1607	TUBO T.PLAS.R7 1/4" FD3/8"-1/4	PIPE R7 1/4" FD3/8"-1/4
1610	TAPPO TESTA ESAGONALE GAS 3/8"	HEX HEAD CAP GAS 3/8"
1611	BULLONE FORATO 14X1.5mm X TUBO SCAR.OLIO	BOLT HOLE 14X1.5mm FOR PIPE OIL
1620	RONDELLA RAME 14X20X1,5	WASHER COPPER 14X20X1,5
1671	BOCCOLA 35X10 FORO D.26	BUSHING 35X10 HOLE D.26
1674	SUPPORTO MOTORE	ENGINE BRACKET
1826	MOLLA PER FRIZIONE BARIKELL 115E	SPRING FOR CLUTCH BARIKELL 115E
1829	COPERCHIO FRIZIO.BARIKELL 115 E DENTATA	CLUTCH COVER BARIKELL 115
4366	MOTORE ROBIN/SUBARU EH65 22HP	ENGINE ROBIN/SUBARU EH65 22 HP

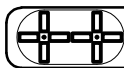
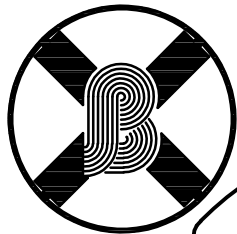

MK8-90

TABLE TAVOLA G4

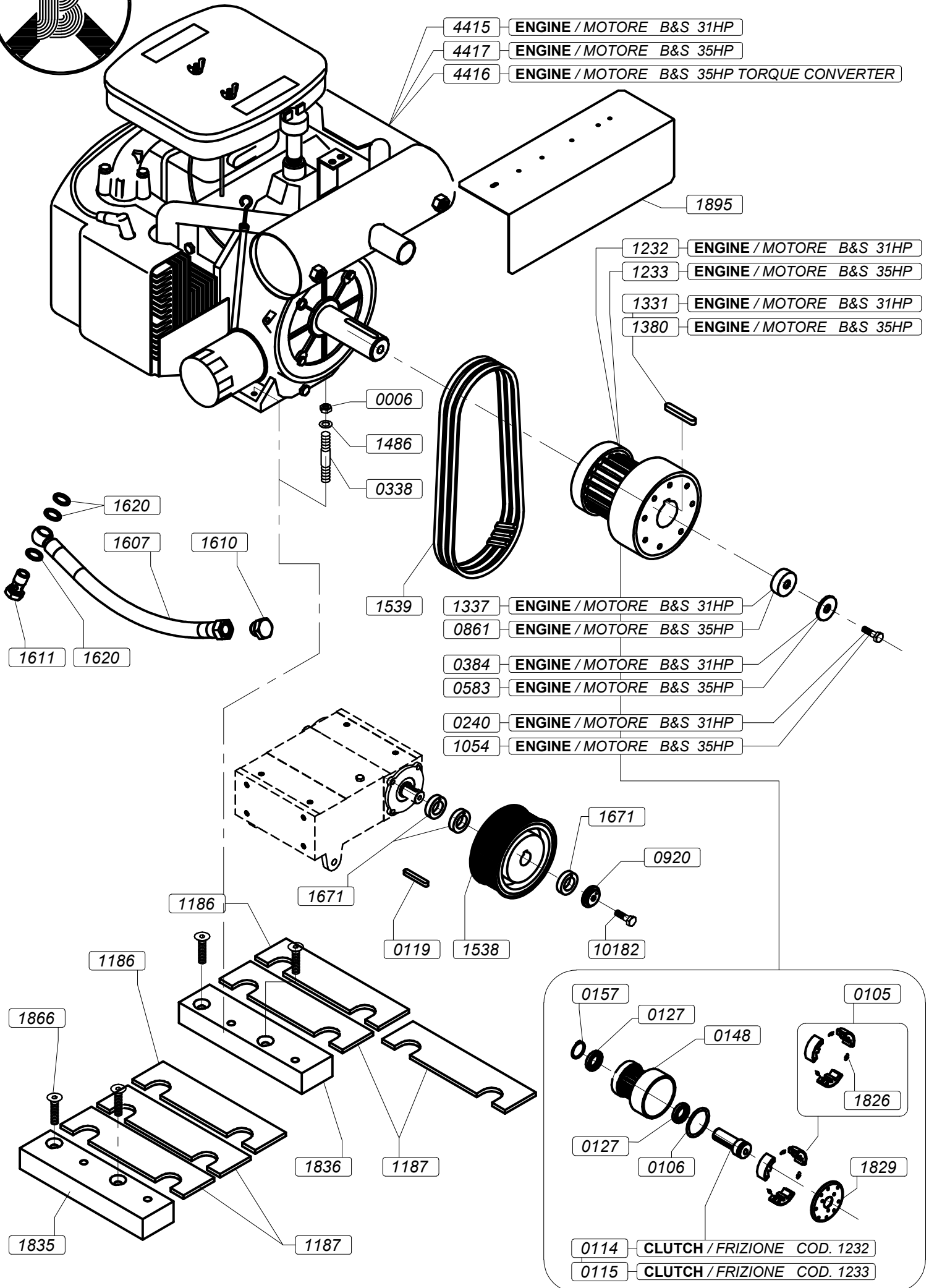

COD.	DESCRIZIONE (I)	DESCRIPTION (GB)
0006	DADO M8 UNI 5588 Z.B.	NUT M8 UNI 5588 ZINC PLATED
0105	SERIE MASSE FRIZIONI DENTATE HTD PER COD. 1232/33/34 RIF.MF621800332	FLYWEIGHT CLUTCH HTD RIF.MF621800332
0106	ANELLO X FRIZIONE DENTATA COD.1232/33/34	JUNT RING CLUTCH COD.1232/33/34
0114	ALBERO TRASCIN.D.28.57 X FRIZ.COD.1232	CLUTCH SHAFT D.28.57 X COD.1232
0115	ALBERO TRASCIN.D.36.51 PER FRIZ.COD.1233	CLUTCH SHAFT D.36.51 X COD.1233
0119	CHIAVETTA 8x7x30 - 6604A	SMALL KEY 8x7x30 - 6604A
0127	CUSCINETTO 6010 2RS X FRIZIONE DENTATA	BEARING 6010 2RS FOR TOOTHED CLUTCH
0148	CAMPANA Ø 138 X FRIZ.DENT COD.1232/33/34	UPPER HEAD Ø 138 FOR TOOTHED CLUTCH COD.1232/33/34
0157	SEEGER "E" 50 UNI 7435-75 X FR.DENTATA	SEEGER "E" 50 UNI 7435-75
0240	VITE TE UNF 7/16x2"1/4	HEX HEAD BOLT UNF 7/16x2"1/4
0338	PRIGIONIERO M8 L=65 X B&S.31HP / 35HP	STUD M8 L=65 B&S.31HP / 35HP
0384	RONDELLA PIANA D.12 6592 ZB	WASHER D.12 6592 ZINC PLATED
0583	RONDELLA GROWER D.16 ZB	WASHER D.16
0861	BOCCOLA FRIZIONE PAF115/B Z.B. B&S 31/35	BUSH FOR PAF115/B
0920	RONDELLA FISSAGGIO	FIXING WASHER
10182	VITE TE 8x30 10.9 5739 ZINC.B.	SOCKET HEAD CAP SCREW 8x30 10.9 5739 ZINC PLATED
1054	VITE TE 5/8x2" UNF	HEX HEAD BOLT UNF 5/8x2"
1186	SPESSORE IN ALLUM.151X30 SP.1	THICKENER 151X30X1
1187	SPESSORE IN ALLUM.149X30 SP.2	THICKENER 149X30X2
1232	FRIZIONE DENTATA D.28.575	CLUTCH D.28.575 1"1/8
1233	FRIZIONE DENTATA D.36.5	CLUTCH D.1"7/16 36.5
1331	CHIAVETTA	KEY
1337	RONDELLA BLOCCAGGIO	LOCKING WASHER
1380	CHIAVETTA	KEY
1486	RONDELLA ZIGRINATA D.8 Z.B.	WASHER D.8 ZINC PLATED
1538	PULEGGIA Z 56X50 M8 D.25 H7 CH8	PULLEY Z 56X50 M8 D.25 H7 CH8
1539	CINGHIA DENTATA HTD 8M 50X880 HCS	TOOTHED BELT HTD 8M 50X880 HCS
1607	TUBO T.PLAS.R7 1/4" FD3/8"-1/4	PIPE R7 1/4" FD3/8"-1/4
1610	TAPPO TESTA ESAGONALE GAS 3/8"	HEX HEAD CAP GAS 3/8"
1611	BULLONE FORATO 14X1.5mm X TUBO SCAR.OLIO	BOLT HOLE 14X1.5mm FOR PIPE OIL
1620	RONDELLA RAME 14X20X1,5	WASHER COPPER 14X20X1,5
1671	BOCCOLA 35X10 FORO D.26	BUSHING 35X10 HOLE D.26
1826	MOLLA PER FRIZIONE BARIKELL 115E	SPRING FOR CLUTCH BARIKELL 115E
1829	COPERCHIO FRIZIO.BARIKELL 115 E DENTATA	CLUTCH COVER BARIKELL 115
1835	STAFFA MOT.ANT.B.& S.31/35 HP	FRONTAL ENGINE BRACKET B&S 31/35HP
1836	STAFFA MOT.POST.B.& S.31/35 HP	BACK ENGINE BRACKET B&S 31/35HP
1866	VITE VSP 10X55 Z.B. 5933	SCREW VSP 10X55 Z.B. 5933
1895	PROTEZIONE MARMITTA	MUFFLER PROTECTION
4415	MOTORE B.& S.VANGUARD 31HP	B&S VANGUARD ENGINE 31HP
4416	MOTORE B.& S.VANGUARD 35HP D.28,575	B&S VANGUARD ENGINE 35HP D.28,575
4417	MOTORE B.& S.VANGUARD 35HP D. 36,5	B&S VANGUARD ENGINE 35HP D. 36,5

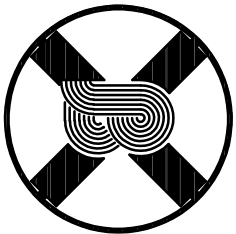

TORQUE CONVERTER



MK8-90

TABLE
TAVOLA **H**

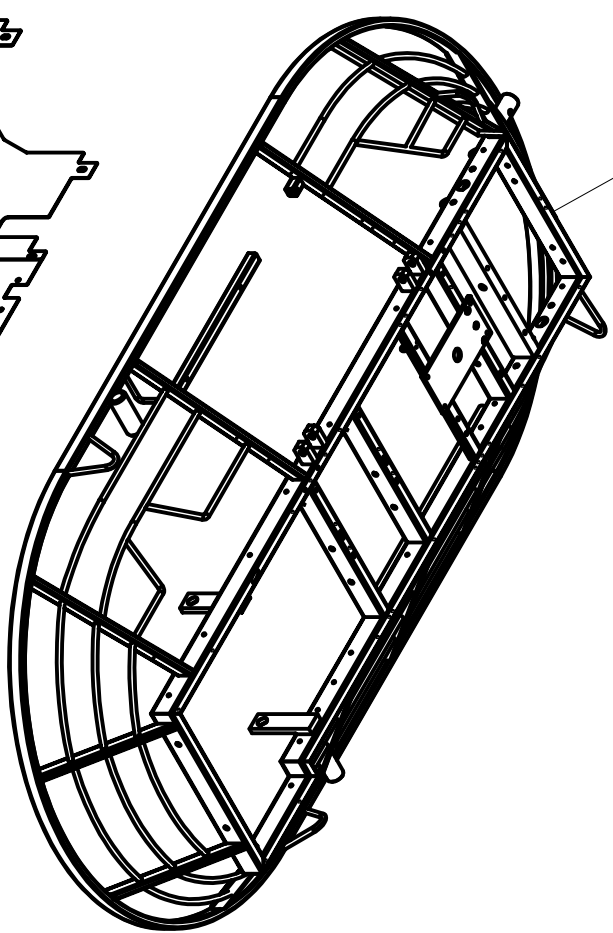

13200

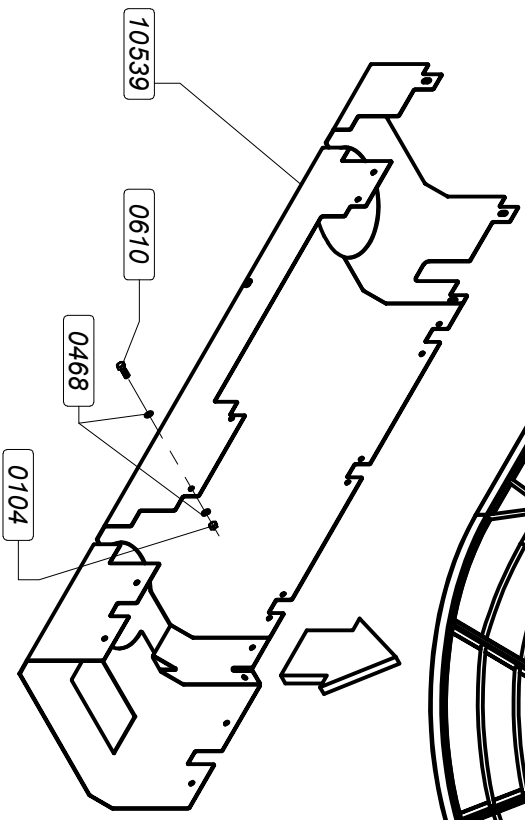

10539

0610

0468

0104

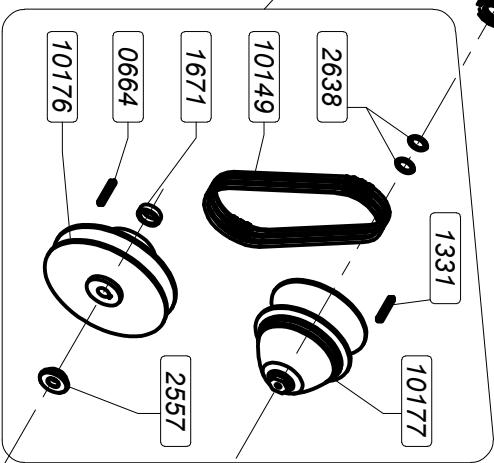

13203 ENGINE / MOTORE B&S

1331

10177

2638

10149

1671

0664

10176

2557

13300

ENGINE / MOTORE B&S 10147
ENGINE / MOTORE KUBOTA 10010
ENGINE / MOTORE KOHLER 10167

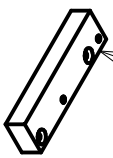
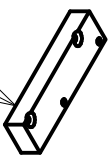

10146 ENGINE / MOTORE B&S
0924 ENGINE / MOTORE KUBOTA
10166 ENGINE / MOTORE KOHLER

1215

10126 ENGINE / MOTORE B&S

1058 ENGINE / MOTORE KUBOTA

10140 ENGINE / MOTORE KOHLER

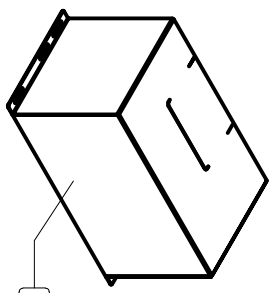

10144

COD.	DESCRIZIONE (I)	DESCRIPTION (GB)
0104	DADO BLOKM6 -DIN 985 Z.B.	BLOK NUT M6 985
0468	RONDELLA 6x18X1,5 Z.B.	PLAIN WASHER 6x18X1,5
0610	VITE TE 6x40 UNI 5737 Z.B.	SCREW TE 6x40 UNI 5737
0924	STAFFA ANTER.SUPP.MOTORE KUBOTA 25HP	ANTERIOR BRACKET FOR KUBOTA ENGINE 25 HP
1058	VITE TE 10x100 5739 ZB T.FIL	HEX HEAD BOLT 10x100 5739 ZINC PLATED
1671	BOCCOLA 35X10 FORO D.26	BUSHING 35X10 HOLE D.26
2557	RONDELLA FISSAGGIO PULEGGIA	PULLEY FIX WASHER
2638	BOCCOLA 29-39 SP.2 GREZZO	BUSHING 29-39 TH.2
10010	STAFFA POST. SUPP.MOTORE KUBOTA 25HP	REAR BRACKET FOR KUBOTA ENGINE 25 HP
10126	VITE TE UNF 7/16x5"	HEX HEAD BOLT 7/16X5"
10140	VITE TE UNF 7/16x4"	SCREW TE UNF 7/16x4"
10144	CARTER FRIZIONE MK8-90/120 CON VARIATORE	CLUTCH CARTER MK8-90/120 WITH VARIABLE SPEED
10145	FRIZIONE TORQUE CONVERTER	CLUTCH TORQUE CONVERTER
10146	STAFFA MOT.ANT.B.& S.31/35 HP con variat	BRACKET ENG.ANT.B.& S.31/35 HP WITH VARIABLE SPEED
10147	STAFFA MOT.POST.B.& S.31/35 HP c/variato	BRACKET ENG.POST.B.& S.31/35 HP WITH VARIABLE SPEED
10149	CINGHIA X TORQUE CONVERTER 0400-0338	BELT FOR TORQUE CONVERTER
10166	STAFFA MOT.ANT.KOHLER TORQUE CONVERTER	ANTERIOR BRACKET FOR KOHLER TORQUE CONVERTER
10167	STAFFA MOT.POST.KOHLER TORQUE CONVERTER	REAR BRACKET FOR KOHLER TORQUE CONVERTER
10176	PULEGGIA CONDOTTA TORQUE CONVERTER	TORQUE CONVERTER DRIVEN PULLEY
10177	PULEGGIA MOTRICE TORQUE CONVERTER	TORQUE CONVERTER DRIVER PULLEY
10539	TUNNEL PROTEZIONE MK8-90 TORQUE CONVERTER	PROTECTION TUNNEL MK8-90 TORQUE CONVERTER
1215	RONDELLA PIANA 10x30 Z.B.	WASHER 10x30 ZINC PLATED
13200	TELAIO PROT.MK8-90 TORQUE CONVERTER	PROTECTION FRAME MK8-90 TORQUE CONVERTER
13203	DISTANZIALE D.45X20 D.28.8	SPACER D.45X20 D.28.8
13204	CARTER PROTEZIONE MK8-90 TORQUE CONVER.	PROTECTION CARTER MK8-90 TORQUE CONVERTER
13300	VITE TCCE 8x55 12.9 UNI5931 DIN 912 Z.B.	SCREW TCCE 8x55 12,9 UNI5931



OPTIONAL

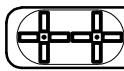

MK8-90

**TABLE
TAVOLA I**

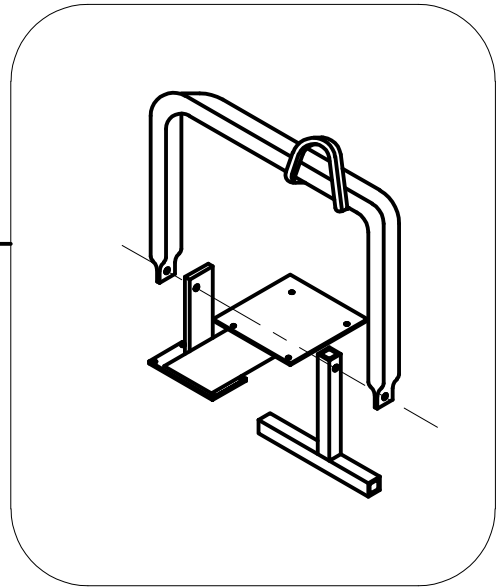

3398

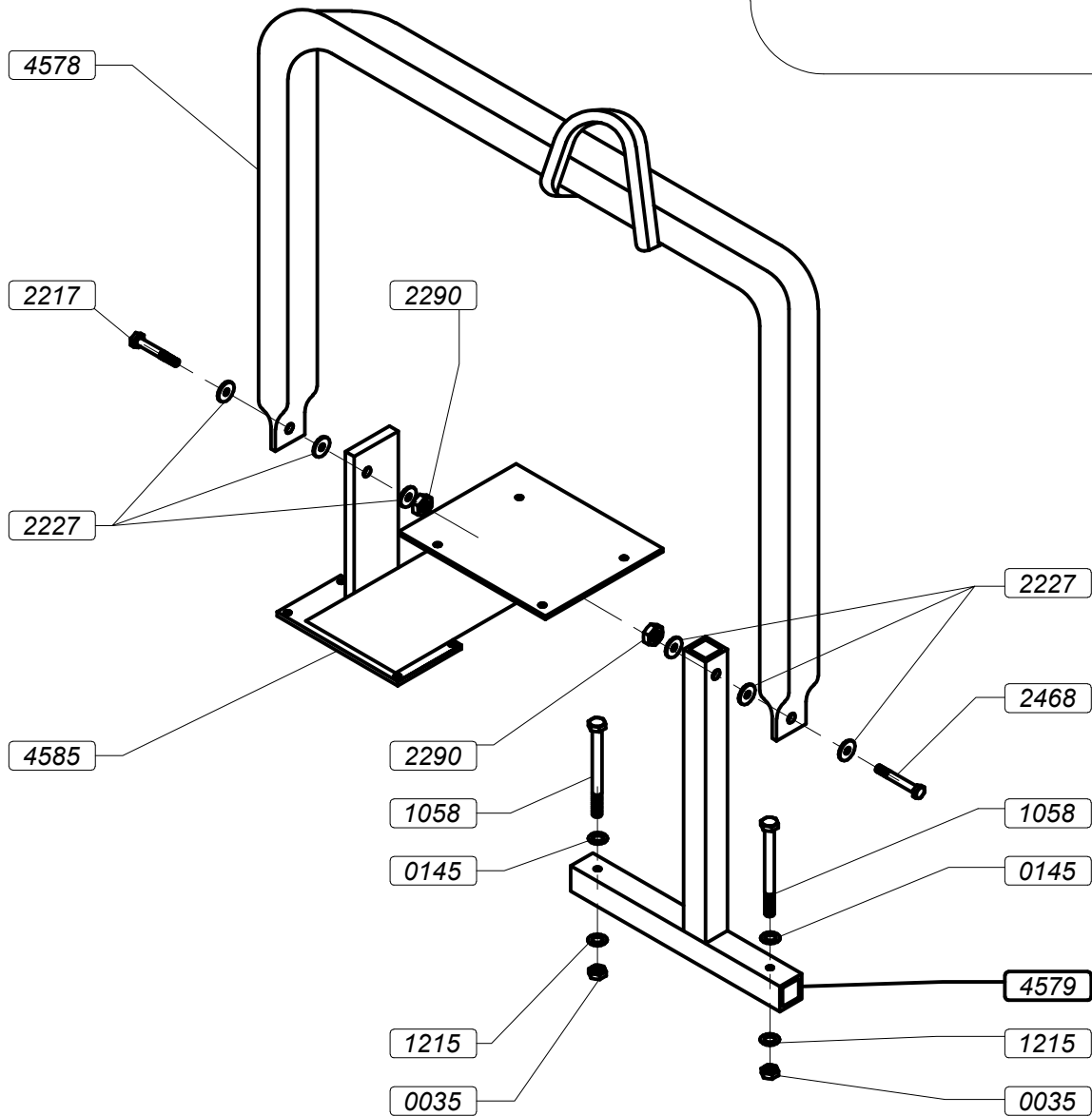

COD.	DESCRIZIONE (I)	DESCRIPTION (GB)
0035	DADO BLOKM10 -985 - Z.B.	SELF-LOCKING NUT M10 -985 ZINC PLATED
0145	RONDELLA PIANA 10x21 6592 Z.B.	WASHER 10x21 6592 ZINC PLATED
1058	VITE TE 10x100 5739 ZB T.FIL	HEX HEAD BOLT 10x100 5739 ZINC PLATED
1215	RONDELLA PIANA 10x30 Z.B.	WASHER 10x30 ZINC PLATED
2217	VITE TE 16X50 UNI 5737 Z.B.	HEX HEAD BOLT 16X50 UNI 5737 ZINC PLATED
2227	RONDELLA 16x30 Z.B.	WASHER 16x30 ZINC PLATED
2290	DADO BLOK M16 DIN 985 Z.B.	SELF-LOCKING NUT M16 DIN 985 ZINC PLATED
2468	VITE TE 16X60 UNI 5737 Z.B.	HEX HEAD BOLT 16X60 UNI 5737 ZINC PLATED
3398	GANCIO SOLLEV.COMPLETO OL120/MK8-90	COMPLETE LIFTING HOOK FOR OL120/MK8-90
4579	TUBOLARE X GANCIO DI SOLLEV.	LIFTING HOOK HCS (FITTING RIGHT)
4578	TUBOLARE CENT. X GAN. SOLLEVAMENTO	LIFTING HOOK CENTRAL PART
4585	PIANTONE SEDILE X GAN. SOLL.OL120 / MK8-90	SEAT SUPPORT

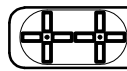

MK8-90

TABLE
TAVOLA **L**

ELECTRICAL SCHEME 12V FOR DOUBLE

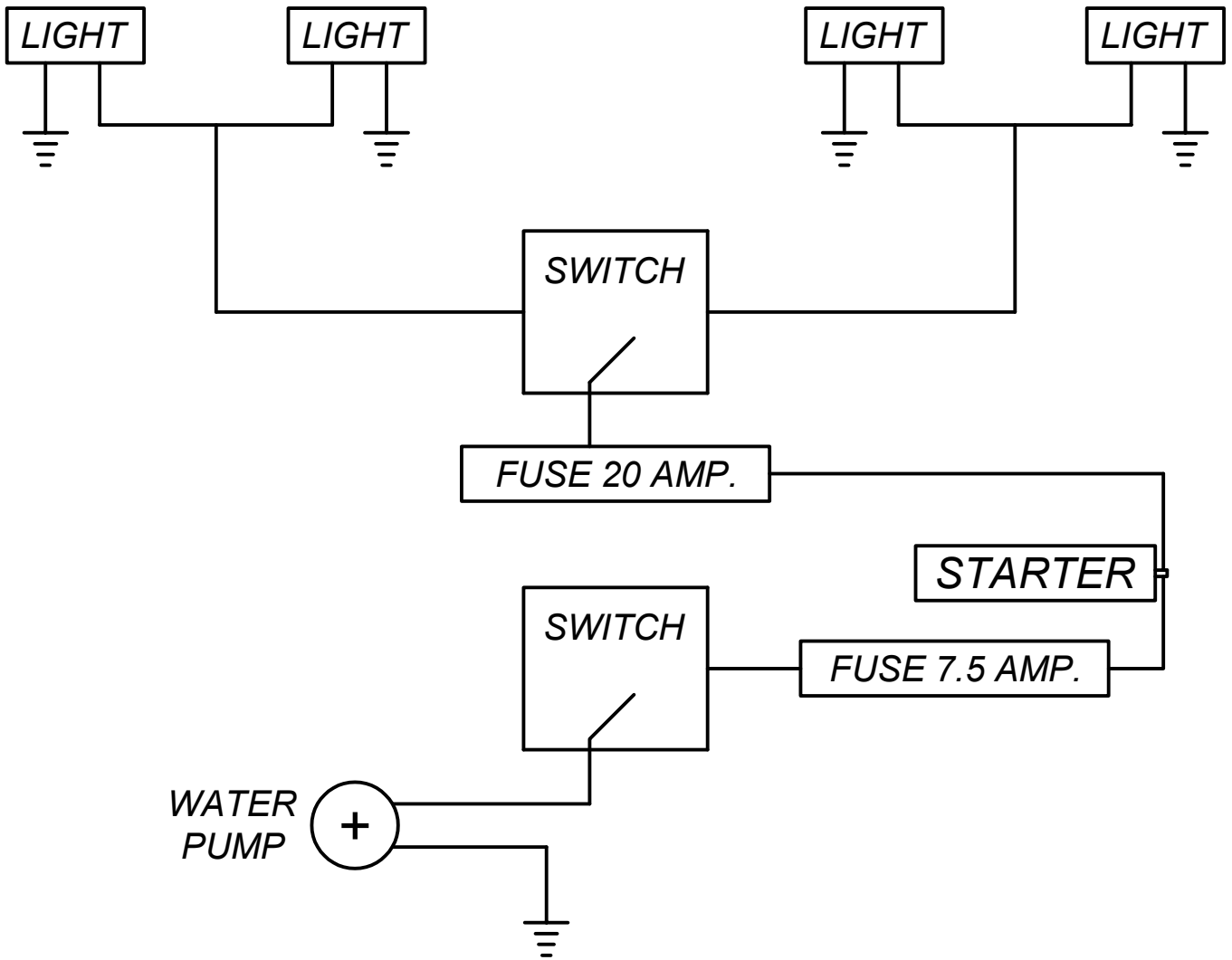

SWITCH SEAT

EMERGENCY

