

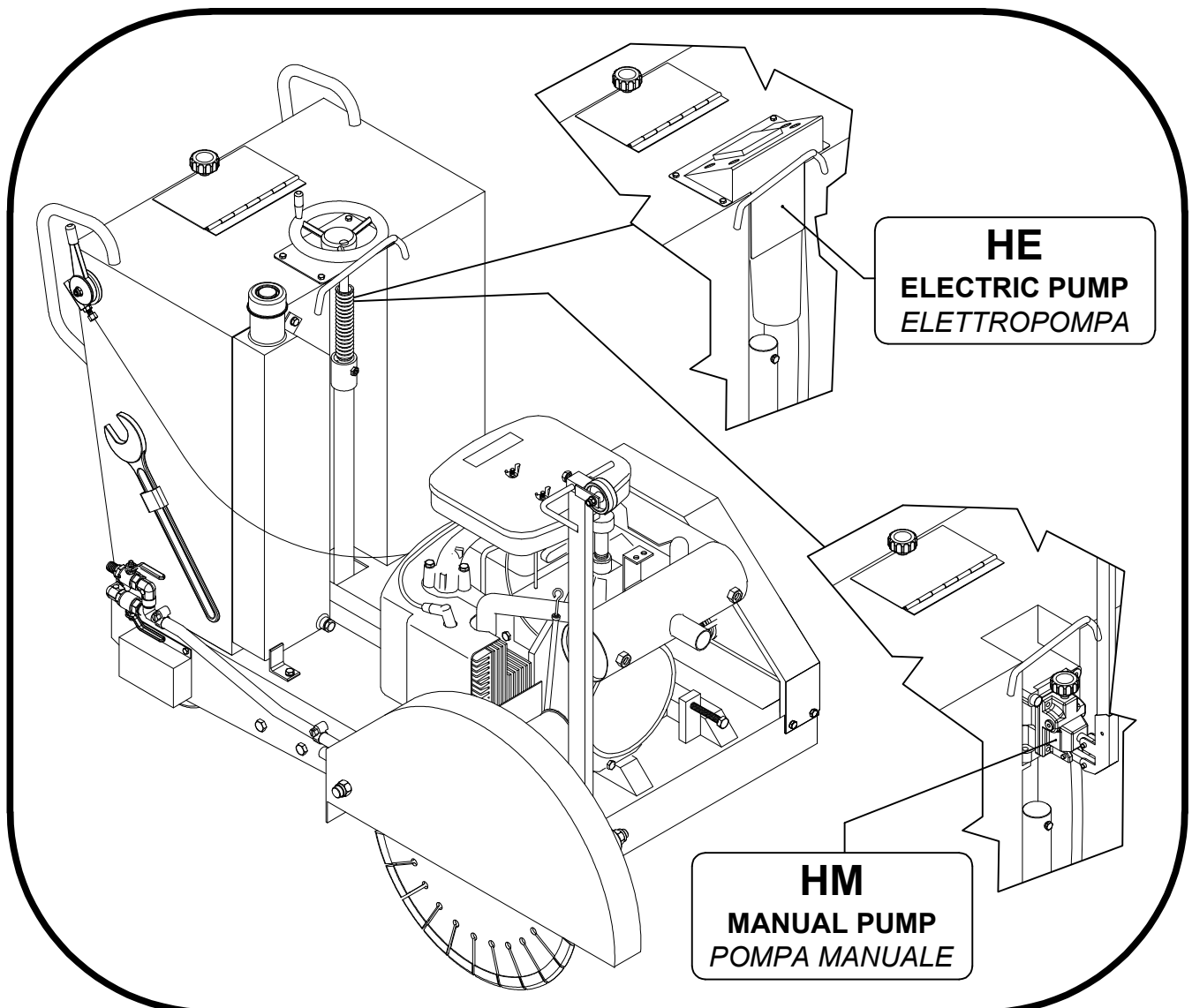

BARIKELL

SPARE PART LIST MANUAL *MANUALE ELENCO PARTI DI RICAMBIO*

**TAGLIAGIUNTI "FLOOR 10"
CUTTING MACHINE "FLOOR 10"**





FLOOR 10

TABLE TAVOLA A1

MOTORE HONDA GX390 AV/S
 MOTORE B&S. 18HP AV/S
 MOTORE ROBIN EX40 AV/S

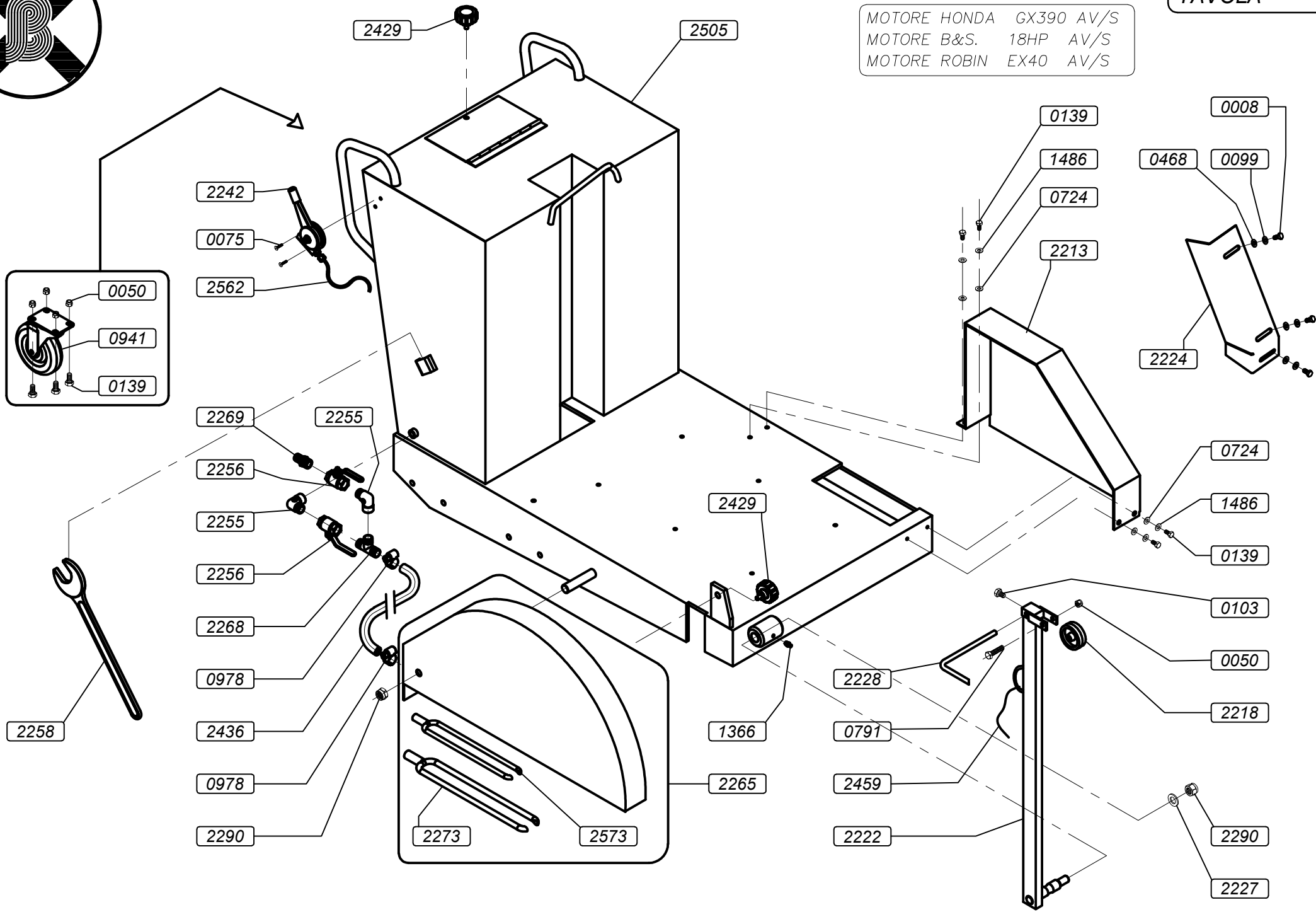

COD.	DESCRIZIONE (I)	DESCRIPTION (GB)
0008	VITE TE 6x16 5739 Z.B.	HEXAGONAL SCREW 6X16
0050	DADO BLOKM8 DIN 985 Z.B.	SELF-LOCKING NUT M8 DIN 985 Z.P.
0075	VITE VSP 6x12 5933 ZINC.	H.S.C.H. SCREW 6X12 UNI 5933 Z.P.
0099	RONDELLA GROWER D. 6 Z.B.	GROWER WASHER D.6
0103	VITE TE 10x16 -5739 - Z.B.	SCREW HEX HEAD 10x16 UNI 5739 ZINC P.
0139	VITE TE 8x16 UNI 5739 Z.B.	SCREW HEX HEAD 8x16 UNI 5739 Z.P.
0468	RONDELLA 6x18X1,5 Z.B.	PLAIN WASHER 6x18X1,5
0724	RONDELLA 8x24 - ZINCATA BIANCA	WASH PLAIN 8X24
0791	VITE TE 8x45 UNI 5737 Z.B.	SCREW HEX HEAD 8x45 UNI 5737 Z.P.
0941	RUOTA PIROTTANTE 125x40/40 m40l/50	SWIVEL CASTOR 125x40/40 m40l/50
0978	FASCETTA VELOX BANDA 8 X TUBO 16-29	HOSE CLAMP VELOX FOR PIPE 16-29
1366	INGRASSATORE M8X1,25	GREASE FITTING M8X1,25
1486	RONDELLA ZIGRINATA D.8 Z.B.	WASHER D.8 ZINC PLATED
2213	CARTER CINGHIE FLOOR 10-20-30	BELT CARTER FOR FLOOR 10-20-30
2218	RUOTA IN NYLON BIANCO D.60X22	WHITE NYLON WHEEL D.60X22
2222	ASTA GUIDA DX FLOOR 10-20-30	ROD GUIDE RIGHT FOR FLOOR 10-20-30
2224	PROTEZIONE CARTER CINGHIE ZINC.	BELT CARTER ZINC PLATED
2227	RONDELLA 16x30 Z.B.	WASHER 16x30 Z.P.
2228	MIRINO DI GUIDA PER FLOOR 10	GUIDE FOR FLOOR 10
2242	LEVA ACCELERATORE MCG/TD/N	ACCELERATOR LEVER MCG/TD/N
2255	RACCORDO 2020-5020 CURVA M+F	CURVED CONNECTION 2020-5020
2256	RUBINETTO FF 1/2" 2210	BALL VALVE 1/2"
2258	CHIAVE PER DISCO "46" 1 BOCCA	DISC KEY "46"
2265	CARTER DISCO DX FLOOR 10-20	CARTER RIGHT FLOOR 10-20
2268	RACCORDO 2080-4010 "T" 1/2"	CONNECTION 2080-4010 "T" 1/2"
2269	PORTAGOMMA 2601-3040 17 1/2"	FITTING 2601-3040 17 1/2"
2273	TUBO RAFFREDDAMENTO DISCO	PIPE DISC COOLING
2290	DADO BLOK M16 DIN 985 Z.B.	SELF-LOCKING NUT M16 DIN 985 Z.P.
2429	VOLANTINO V1/50/V - M8X15	LOCK V1/50/V - M8X15
2436	TUBO ARMORVIN HNA D.16	PIPE ARMORVIN HNA D.16
2459	TRECCIA POLIESTERE PAP05	POLYESTER ROPE
2505	TELAIO FLOOR 10	CHASSIS FOR FLOOR 10
2562	FILO ACCELERATORE X FLOOR ASPHALT	ACCELERATOR CABLE FOR FLOOR
2573	TUBO RAFFREDDAMENTO DISCO	PIPE DISC COOLING



FLOOR 10

**TABLE
TAVOLA A2**

MOTORE B. & S. 18HP AV/S&EL

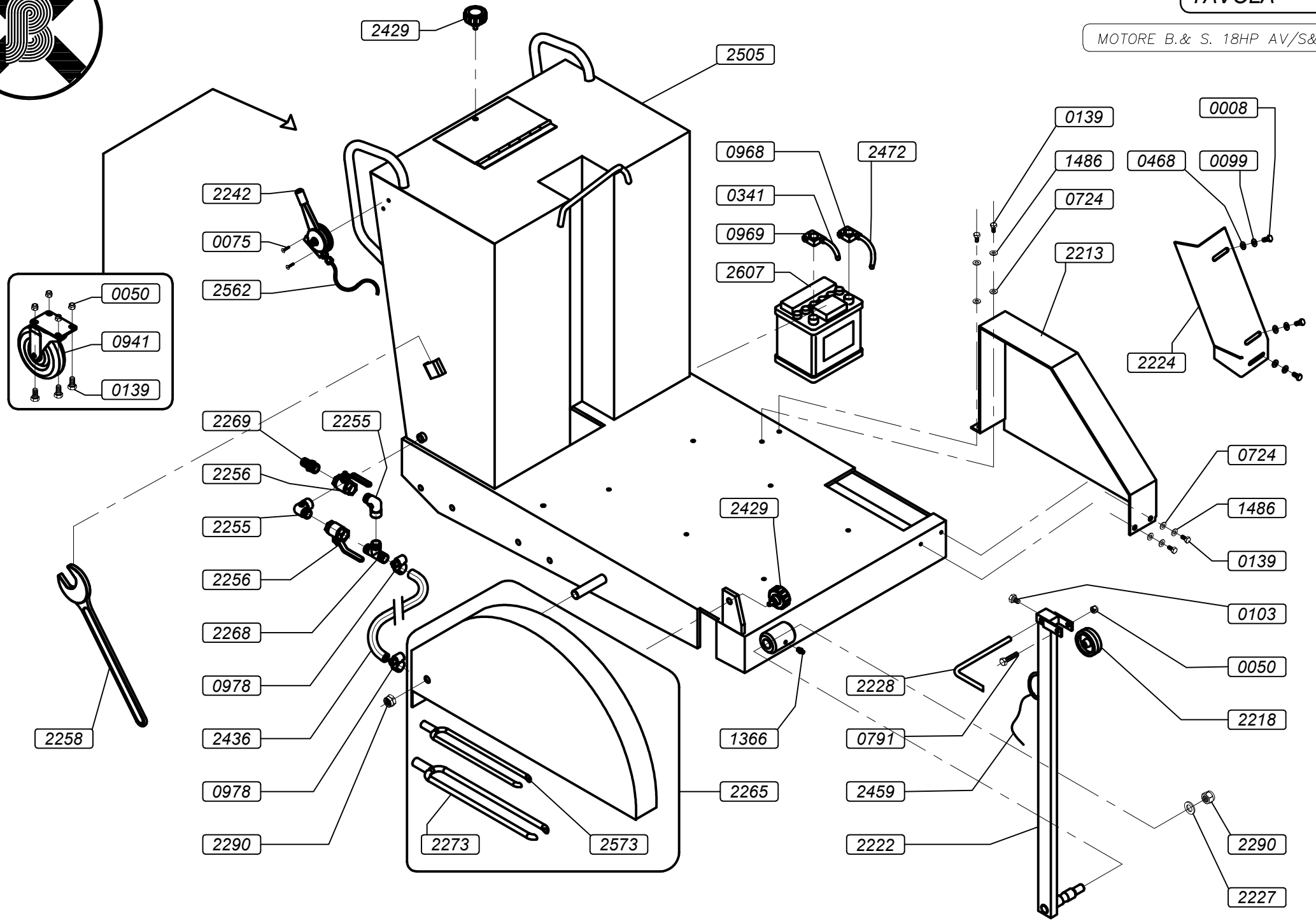

- 2429
- 2505
- 0968
- 0341
- 0969
- 2607
- 2472
- 0139
- 0008
- 1486
- 0468
- 0009
- 0724
- 2213
- 2224
- 2229
- 2227
- 2228
- 0103
- 0050
- 2218
- 2459
- 2222
- 2290
- 2225
- 2226
- 2228
- 0791
- 2436
- 0978
- 2273
- 2573
- 2265
- 1366
- 2269
- 2255
- 2256
- 2255
- 2256
- 2268
- 0978
- 2436
- 0978
- 2290

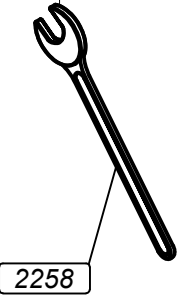
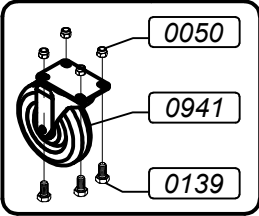

COD.	DESCRIZIONE (I)	DESCRIPTION (GB)
0008	VITE TE 6x16 5739 Z.B.	HEXAGONAL SCREW 6X16
0050	DADO BLOKM8 DIN 985 Z.B.	SELF-LOCKING NUT M8 DIN 985 Z.P.
0075	VITE VSP 6x12 5933 ZINC.	H.S.C.H. SCREW 6X12 UNI 5933 Z.P.
0099	RONDELLA GROWER D. 6 Z.B.	GROWER WASHER D.6
0103	VITE TE 10x16 -5739 - Z.B.	SCREW HEX HEAD 10x16 UNI 5739 ZINC P.
0139	VITE TE 8x16 UNI 5739 Z.B.	SCREW HEX HEAD 8x16 UNI 5739 ZINC PLATED
0341	CAVO POSITIVO X DOPPIE L=2000	BATTERY CABLE POSITIVE L=2000
0468	RONDELLA 6x18X1,5 Z.B.	PLAIN WASHER 6x18X1,5
0724	RONDELLA 8x24 - ZINCATA BIANCA	WASH PLAIN 8X24
0791	VITE TE 8x45 UNI 5737 Z.B.	SCREW HEX HEAD 8x45 UNI 5737 ZINC PLATED
0941	RUOTA PIROETTANTE 125x40/40 m40I/50	SWIVEL CASTOR 125x40/40 m40I/50
0968	MORSETTO "+"PER BATTERIA	"+" TERMINAL FOR BATTERY
0969	MORSETTO "-" PER BATTERIA	"-" TERMINAL FOR BATTERY
0978	FASCETTA VELOX BANDA 8 X TUBO 16-29	HOSE CLAMP VELOX FOR PIPE 16-29
1366	INGRASSATORE M8X1,25	GREASE FITTING M8X1,25
1486	RONDELLA ZIGRINATA D.8 Z.B.	WASHER D.8 ZINC PLATED
2213	CARTER CINGHIE FLOOR 10-20-30	BELT CARTER FOR FLOOR 10-20-30
2218	RUOTA IN NYLON BIANCO D.60X22	WHITE NYLON WHEEL D.60X22
2222	ASTA GUIDA DX FLOOR 10-20-30	ROD GUIDE RIGHT FOR FLOOR 10-20-30
2224	PROTEZIONE CARTER CINGHIE ZINCATO BIANCO	BELT CARTER ZINC PLATED
2227	RONDELLA 16x30 Z.B.	WASHER 16x30 Z.P.
2228	MIRINO DI GUIDA PER FLOOR 10	GUIDE FOR FLOOR 10
2242	LEVA ACCELERATORE MCG/TD/N	ACCELERATOR LEVER MCG/TD/N
2255	RACCORDO 2020-5020 CURVA M+F	CURVED CONNECTION 2020-5020
2256	RUBINETTO FF 1/2" 2210	BALL VALVE 1/2"
2258	CHIAVE PER DISCO "46" 1 BOCCA	DISC KEY "46"
2265	CARTER DISCO DX FLOOR 10-20	CARTER RIGHT FLOOR 10-20
2268	RACCORDO 2080-4010 "T" 1/2"	CONNECTION 2080-4010 "T" 1/2"
2269	PORTAGOMMA 2601-3040 17 1/2"	FITTING 2601-3040 17 1/2"
2273	TUBO RAFFREDDAMENTO DISCO	PIPE DISC COOLING
2290	DADO BLOK M16 DIN 985 Z.B.	SELF-LOCKING NUT M16 DIN 985 Z.P.
2429	VOLANTINO V1/50/V - M8X15	LOCK V1/50/V - M8X15
2436	TUBO ARMORVIN HNA D.16	PIPE ARMORVIN HNA D.16
2459	TRECCIA POLIESTERE PAP05	POLYESTER ROPE
2472	CAVO BATTERIA + L=1250	CABLE BATTERY + L=1250
2505	TELAIO FLOOR 10	CHASSIS FOR FLOOR 10
2562	FILO ACCELERATORE X FLOOR ASPHALT	ACCELERATOR CABLE FOR FLOOR
2573	TUBO RAFFREDDAMENTO DISCO	PIPE DISC COOLING
2607	BATTERIA 12V 35AH EUROSTAR DX	BATTERY 12V 35AH EUROSTAR DX



MOTORE HONDA COD.3450-3452
MOTORE ROBIN COD.3463
MOTORE KOHLER COD.3470-3472-3473

FLOOR 10

TABLE TAVOLA A3

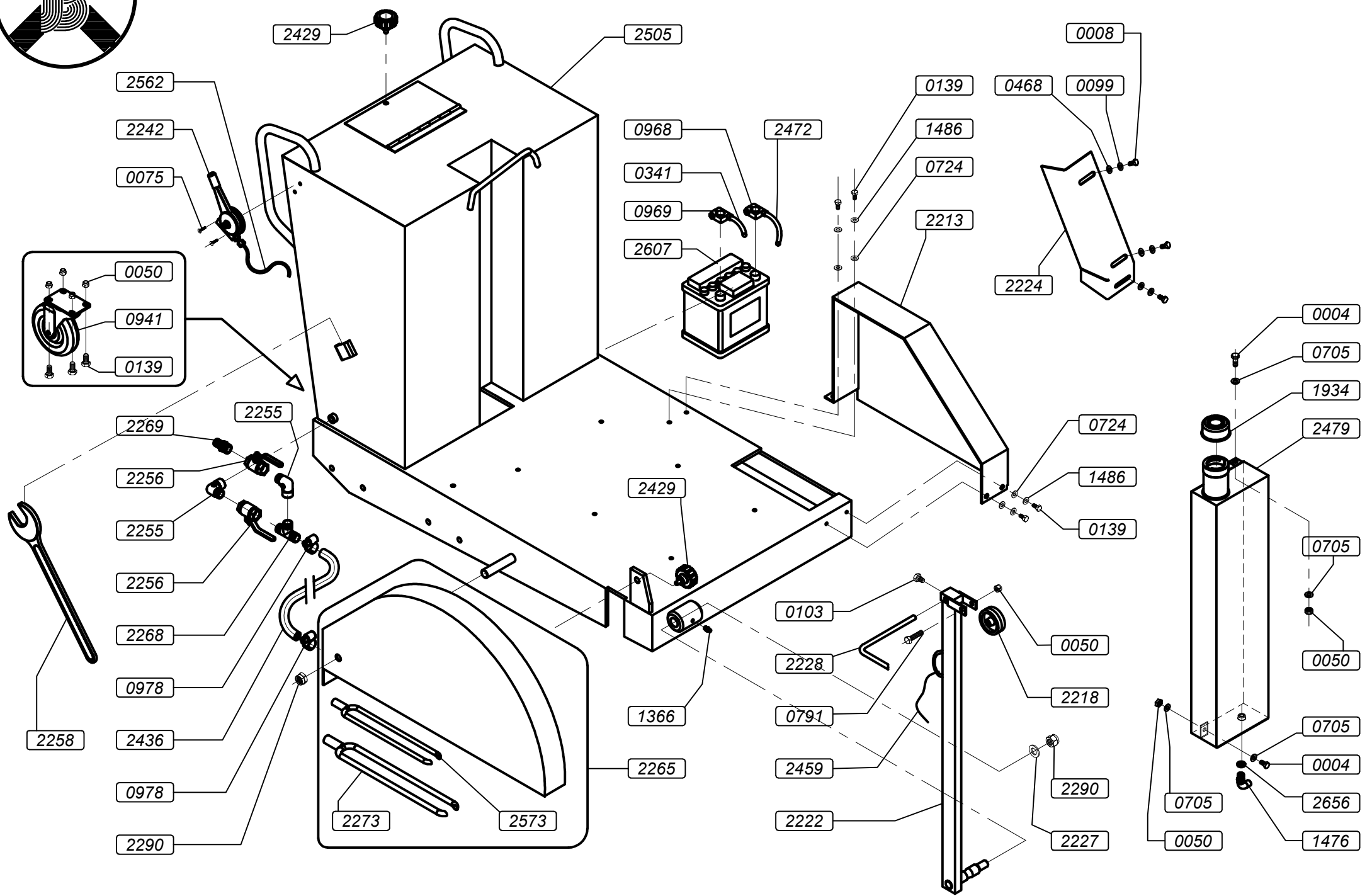

COD.	DESCRIZIONE (I)	DESCRIPTION (GB)
0004	VITE TE 8x20 UNI 5739 Z.B.	HEX HEAD BOLT 8x20 UNI 5739 Z.P.
0008	VITE TE 6x16 5739 Z.B.	HEXAGONAL SCREW 6X16
0050	DADO BLOKM8 DIN 985 Z.B.	SELF-LOCKING NUT M8 DIN 985 Z.P.
0075	VITE VSP 6x12 5933 ZINC.	H.S.C.H. SCREW 6X12 UNI 5933 Z.P.
0099	RONDELLA GROWER D. 6 Z.B.	GROWER WASHER D.6
0103	VITE TE 10x16 -5739 - Z.B.	SCREW HEX HEAD 10x16 UNI 5739 ZINC P.
0139	VITE TE 8x16 UNI 5739 Z.B.	SCREW HEX HEAD 8x16 UNI 5739 Z.P.
0341	CAVO POSITIVO X DOPPIE L=2000	BATTERY CABLE POSITIVE L=2000
0468	RONDELLA 6x18X1,5 Z.B.	PLAIN WASHER 6x18X1,5
0705	RONDELLA PIANA D. 8 Z.B.	WASHER D. 8 ZINC PLATED
0791	VITE TE 8x45 UNI 5737 Z.B.	SCREW HEX HEAD 8x45 UNI 5737 Z.P.
0941	RUOTA PIROETTANTE 125x40/40 m40l/50	SWIVEL CASTOR 125x40/40 m40l/50
0968	MORSETTO "+"PER BATTERIA	"+" TERMINAL FOR BATTERY
0969	MORSETTO "-" PER BATTERIA	"-" TERMINAL FOR BATTERY
0978	FASCETTA VELOX BANDA 8 X TUBO 16-29	HOSE CLAMP VELOX FOR PIPE 16-29
1366	INGRASSATORE M8X1,25	GREASE FITTING M8X1,25
1476	RACCORDO PER SERBATOIO	FITTING FOR TANK
1486	RONDELLA ZIGRINATA D.8 Z.B.	WASHER D.8 ZINC PLATED
1934	TAPPO 2 LOBI BAIONETTA D.60	BAYONET PLUG D.60
2213	CARTER CINGHIE FLOOR 10-20-30	BELT CARTER FOR FLOOR 10-20-30
2218	RUOTA IN NYLON BIANCO D.60X22	WHITE NYLON WHEEL D.60X22
2222	ASTA GUIDA DX FLOOR 10-20-30	ROD GUIDE RIGHT FOR FLOOR 10-20-30
2224	PROTEZIONE CARTER CINGHIE Z.B.	BELT CARTER ZINC PLATED
2227	RONDELLA 16x30 Z.B.	WASHER 16x30 Z.P.
2228	MIRINO DI GUIDA PER FLOOR 10	GUIDE FOR FLOOR 10
2242	LEVA ACCELERATORE MCG/TD/N	ACCELERATOR LEVER MCG/TD/N
2255	RACCORDO 2020-5020 CURVA M+F	CURVED CONNECTION 2020-5020
2256	RUBINETTO FF 1/2" 2210	BALL VALVE 1/2"
2258	CHIAVE PER DISCO "46" 1 BOCCA	DISC KEY "46"
2265	CARTER DISCO DX FLOOR 10-20	CARTER RIGHT FLOOR 10-20
2268	RACCORDO 2080-4010 "T" 1/2"	CONNECTION 2080-4010 "T" 1/2"
2269	PORTAGOMMA 2601-3040 17 1/2"	FITTING 2601-3040 17 1/2"
2273	TUBO RAFFREDDAMENTO DISCO	PIPE DISC COOLING
2290	DADO BLOK M16 DIN 985 Z.B.	SELF-LOCKING NUT M16 DIN 985 Z.P.
2429	VOLANTINO V1/50/V - M8X15	LOCK V1/50/V - M8X15
2436	TUBO ARMORVIN HNA D.16	PIPE ARMORVIN HNA D.16
2459	TRECCIA POLIESTERE PAPO5	POLYESTER ROPE
2472	CAVO BATTERIA + L=1250	CABLE BATTERY + L=1250
2479	SERBATOIO BENZINA FLOOR 10-20	FUEL TANK FLOOR 10-20
2505	TELAIO FLOOR 10	CHASSIS FOR FLOOR 10
2562	FILO ACCELERATORE X FLOOR ASPHALT	ACCELERATOR CABLE FOR FLOOR
2573	TUBO RAFFREDDAMENTO DISCO	PIPE DISC COOLING
2607	BATTERIA 12V 35AH EUROSTAR DX	BATTERY 12V 35AH EUROSTAR DX
2656	RONDELLA FERRO-GOMMA D12	WASHER IRON-RUBBER D12



FLOOR 10

TABLE TAVOLA A4

MOTORE LOMBARDINI LD350/LD440

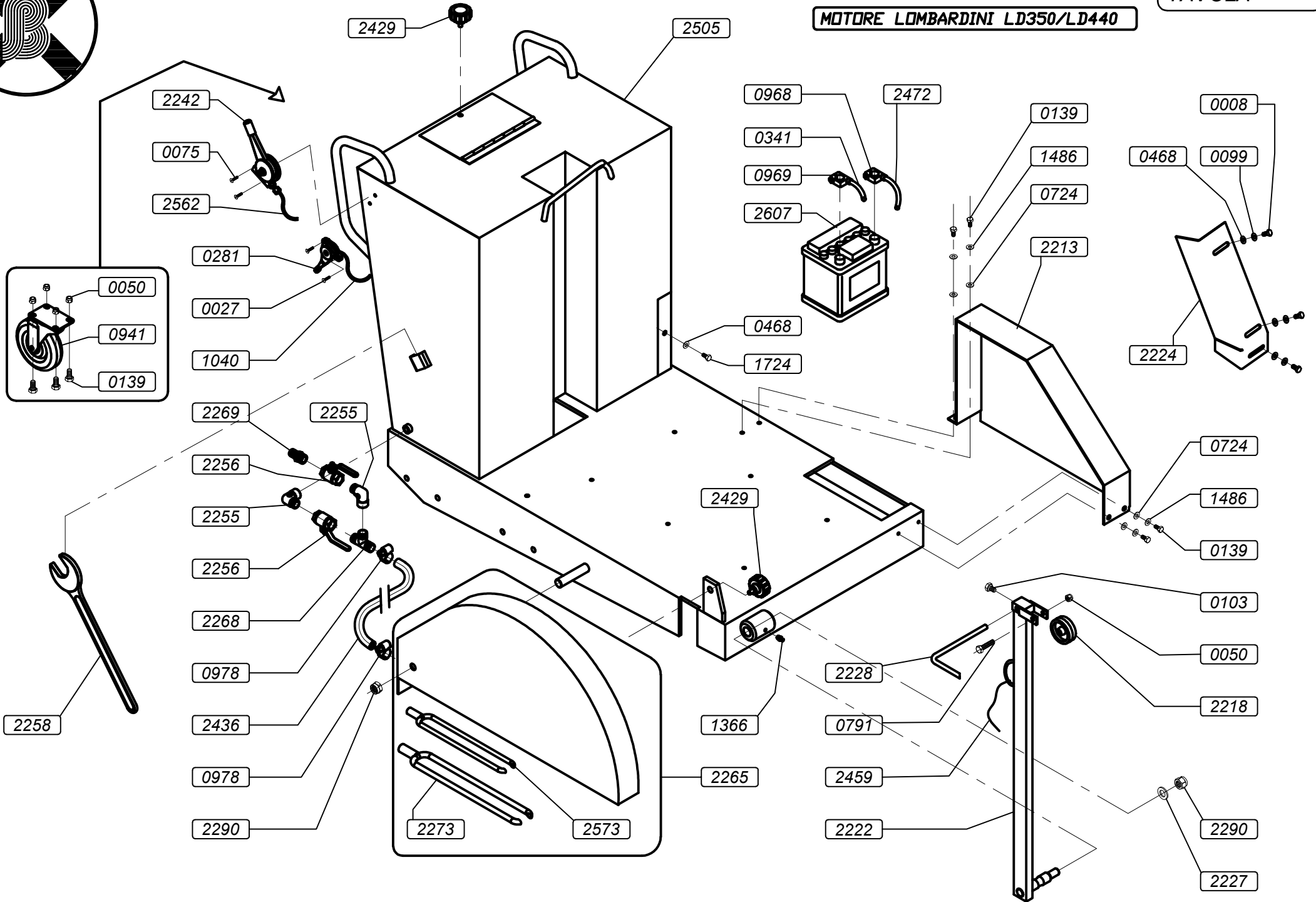

COD.	DESCRIZIONE (I)	DESCRIPTION (GB)
0008	VITE TE 6x16 5739 Z.B.	SCREW HEX HEAD 6x16 5739 ZINC PLATED
0027	VITE TCCE 5x10 5931 Z.B.	SCREW 5x10 5931 ZINC PLATED
0050	DADO BLOKM8 DIN 985 Z.B.	SELF-LOCKING NUT M8 DIN 985 Z.P.
0075	VITE VSP 6x12 5933 ZINC.	H.S.C.H. SCREW 6X12 UNI 5933 Z.P.
0099	RONDELLA GROWER D. 6 Z.B.	WASHER GROWER D. 6 ZINC PLATED
0103	VITE TE 10x16 -5739 - Z.B.	SCREW HEX HEAD 10x16 UNI 5739 ZINC P.
0139	VITE TE 8x16 UNI 5739 Z.B.	SCREW HEX HEAD 8x16 UNI 5739 Z.P.
0281	LEVA ACCELERATORE METALLO	METAL ACCELERATOR LEVER
0341	CAVO POSITIVO X DOPPIE L=2000	BATTERY CABLE POSITIVE L=2000
0468	RONDELLA 6x18X1,5 Z.B.	WASHER 6x18X1,5 ZINC PLATED
0724	RONDELLA 8x24 - ZINCATA BIANCA	WASHER 8x24 - ZINC PLATED
0791	VITE TE 8x45 UNI 5737 Z.B.	SCREW HEX HEAD 8x45 UNI 5737 Z.P.
0941	RUOTA PIROETTANTE 125x40/40 m40I/50	SWIVEL CASTOR 125x40/40 m40I/50
0968	MORSETTO "+"PER BATTERIA	"+" TERMINAL FOR BATTERY
0969	MORSETTO "-" PER BATTERIA	"-" TERMINAL FOR BATTERY
0978	FASCETTA VELOX BANDA 8 X TUBO 16-29	HOSE CLAMP VELOX FOR PIPE 16-29
1040	FILO C/GUAINA 1,5x1900x1800 -	CABLE WITH SHEATH 1,5x1900x1800
1366	INGRASSATORE M8X1,25	GREASE FITTING M8X1,25
1486	RONDELLA ZIGRINATA D.8 Z.B.	WASHER D.8 ZINC PLATED
1724	GALLETTO M6X16 C/VITE 5449 Z.B	SCREW HEX HEAD M6X16 UNI 5449 ZINC P.
2213	CARTER CINGHIE FLOOR 10-20-30	BELT CARTER FOR FLOOR 10-20-30
2218	RUOTA IN NYLON BIANCO D.60X22	WHITE NYLON WHEEL D.60X22
2222	ASTA GUIDA DX FLOOR 10-20-30	ROD GUIDE RIGHT FOR FLOOR 10-20-30
2224	PROTEZIONE CARTER CINGHIE Z.B.	BELT CARTER ZINC PLATED
2227	RONDELLA 16x30 Z.B.	WASHER 16x30 Z.P.
2228	MIRINO DI GUIDA PER FLOOR 10	GUIDE FOR FLOOR 10
2242	LEVA ACCELERATORE MCG/TD/N	ACCELERATOR LEVER MCG/TD/N
2255	RACCORDO 2020-5020 CURVA M+F	CURVED CONNECTION 2020-5020
2256	RUBINETTO FF 1/2" 2210	BALL VALVE 1/2"
2258	CHIAVE PER DISCO "46" 1 BOCCA	DISC KEY "46"
2265	CARTER DISCO DX FLOOR 10-20	CARTER RIGHT FLOOR 10-20
2268	RACCORDO 2080-4010 "T" 1/2"	CONNECTION 2080-4010 "T" 1/2"
2269	PORTAGOMMA 2601-3040 17 1/2"	FITTING 2601-3040 17 1/2"
2273	TUBO RAFFREDDAMENTO DISCO	PIPE DISC COOLING
2290	DADO BLOK M16 DIN 985 Z.B.	SELF-LOCKING NUT M16 DIN 985 Z.P.
2429	VOLANTINO V1/50/V - M8X15	LOCK V1/50/V - M8X15
2436	TUBO ARMORVIN HNA D.16	PIPE ARMORVIN HNA D.16
2459	TRECCIA POLIESTERE PAP05	POLYESTER ROPE
2472	CAVO BATTERIA + L=1250	CABLE BATTERY + L=1250
2505	TELAIO FLOOR 10	CHASSIS FOR FLOOR 10
2562	FILO ACCELERATORE X FLOOR ASPHALT	ACCELERATOR CABLE FOR FLOOR
2573	TUBO RAFFREDDAMENTO DISCO	PIPE DISC COOLING
2607	BATTERIA 12V 35AH EUROSTAR DX	BATTERY 12V 35AH EUROSTAR DX



**DOUBLE BLADE
DOPPIA LAMA**

FLOOR 10

**TABLE
TAVOLA A5**

- MOTORE HONDA
- MOTORE B&S
- MOTORE ROBIN
- MOTORE KOHLER
- MOTORE LOMBARDINI

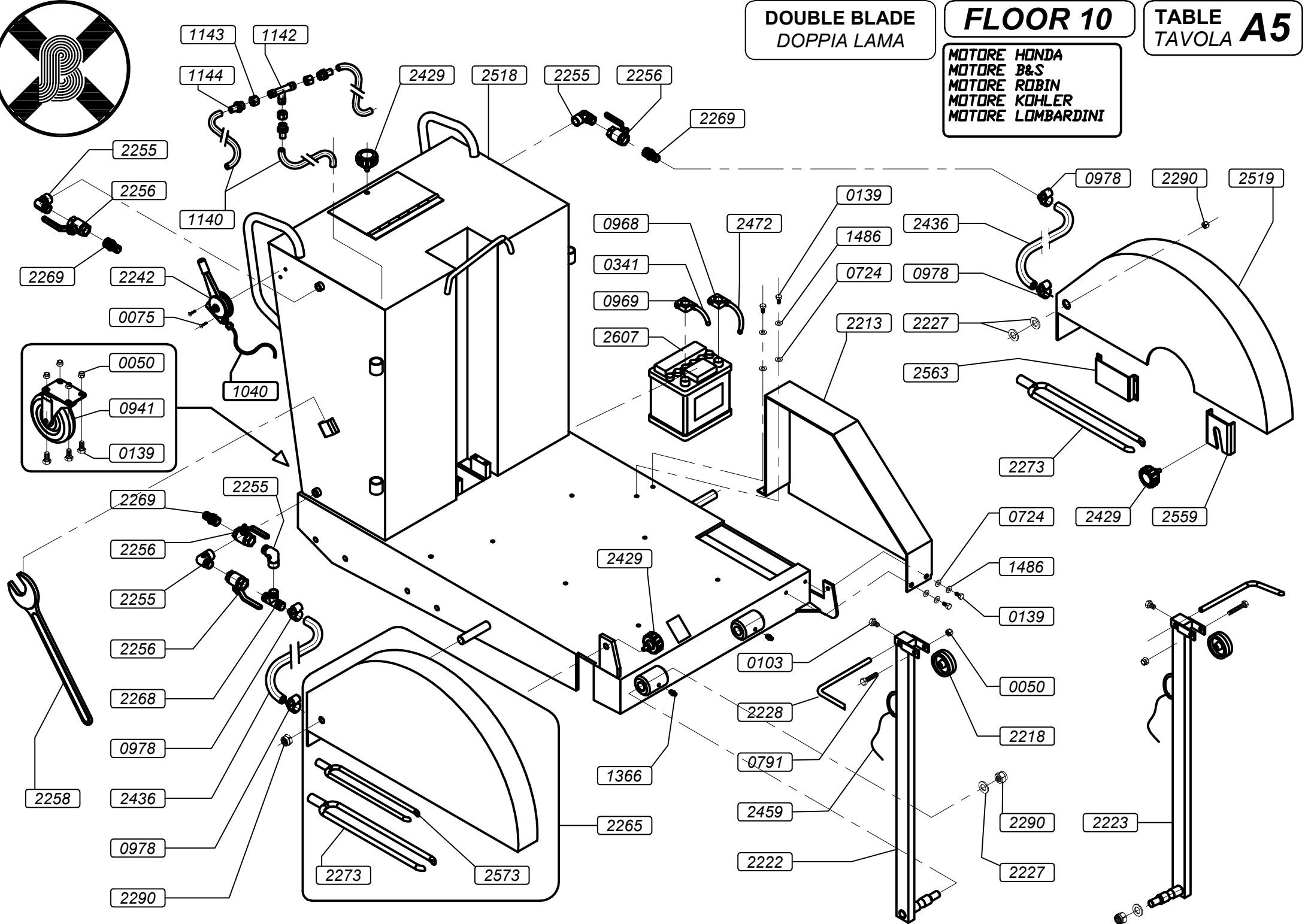

- 1143
- 1142
- 1144
- 2429
- 2518
- 2255
- 2256
- 2269

- 2255
- 2256
- 2269
- 2242
- 0075

- 0050
- 0941
- 0139

- 1040
- 2269
- 2255
- 2256
- 2255
- 2256
- 2268
- 0978
- 2258
- 2436
- 0978
- 2290

- 0968
- 0341
- 0969
- 2607

- 2472
- 0139
- 1486
- 0724
- 2213
- 2227

- 0978
- 2290
- 2519
- 2436
- 0978
- 2563
- 2273
- 0724
- 2429
- 2559

- 2429
- 0103
- 2228
- 0791
- 2459
- 2222
- 1366
- 2265
- 0050
- 2218
- 2290
- 2227

- 2223

COD.	DESCRIZIONE (I)	DESCRIPTION (GB)
0050	DADO BLOKM8 DIN 985 Z.B.	SELF-LOCKING NUT M8 DIN 985 Z.P.
0075	VITE VSP 6x12 5933 ZINC.	H.S.C.H. SCREW 6X12 UNI 5933 Z.P.
0103	VITE TE 10x16 -5739 - Z.B.	SCREW HEX HEAD 10x16 UNI 5739 ZINC P.
0139	VITE TE 8x16 UNI 5739 Z.B.	SCREW HEX HEAD 8x16 UNI 5739 Z.P.
0341	CAVO POSITIVO X DOPPIE L=2000	BATTERY CABLE POSITIVE L=2000
0724	RONDELLA 8x24 - ZINCATA BIANCA	WASHER 8x24 - ZINC PLATED
0791	VITE TE 8x45 UNI 5737 Z.B.	SCREW HEX HEAD 8x45 UNI 5737 Z.P.
0941	RUOTA PIROETTANTE 125x40/40 m40I/50	SWIVEL CASTOR 125x40/40 m40I/50
0968	MORSETTO "+" PER BATTERIA 27150	CLAMP "+" FOR BATTERY 27150
0969	MORSETTO "-" PER BATTERIA 27160	CLAMP "-" FOR BATTERY 27160
0978	FASCETTA VELOX BANDA 8 X TUBO 16-29	HOSE CLAMP VELOX FOR PIPE 16-29
1040	FILO C/GUAINA 1,5x1900x1800 -	CABLE WITH SHEATH 1,5x1900x1800
1142	RACCORDO MOD.2300-4000 1/8"	CONNECTION MOD.2300-4000 1/8"
1143	RIDUZIONE 2520-2040 1/8"-1/4"	REDUCER 2520-2040 1/8"-1/4"
1144	PORTAGOMMA MOD. 2601-3040 12-1/4"	FITTING MOD.2601-3040 12-1/4"
1366	INGRASSATORE M8X1,25	GREASE FITTING M8X1,25
1486	RONDELLA ZIGRINATA D.8 Z.B.	WASHER D.8 ZINC PLATED
2213	CARTER CINGHIE FLOOR 10-20-30	BELT CARTER FOR FLOOR 10-20-30
2218	RUOTA IN NYLON BIANCO D.60X22	WHITE NYLON WHEEL D.60X22
2222	ASTA GUIDA DX FLOOR 10-20-30	ROD GUIDE RIGHT FOR FLOOR 10-20-30
2223	ASTA GUIDA SX FLOOR 10-20-30	ROD GUIDE LEFT FOR FLOOR 10-20-30
2227	RONDELLA 16x30 Z.B.	WASHER 16x30 Z.P.
2228	MIRINO DI GUIDA PER FLOOR 10	GUIDE FOR FLOOR 10
2242	LEVA ACCELERATORE MCG/TD/N	ACCELERATOR LEVER MCG/TD/N
2255	RACCORDO 2020-5020 CURVA M+F	CURVED CONNECTION 2020-5020
2256	RUBINETTO FF 1/2" 2210	BALL VALVE 1/2"
2258	CHIAVE PER DISCO "46" 1 BOCCA	DISC KEY "46"
2265	CARTER DISCO DX FLOOR 10-20	CARTER RIGHT FLOOR 10-20
2268	RACCORDO 2080-4010 "T" 1/2"	CONNECTION 2080-4010 "T" 1/2"
2269	PORTAGOMMA 2601-3040 17 1/2"	FITTING 2601-3040 17 1/2"
2273	TUBO RAFFREDDAMENTO DISCO	PIPE DISC COOLING
2290	DADO BLOK M16 DIN 985 Z.B.	SELF-LOCKING NUT M16 DIN 985 Z.P.
2429	VOLANTINO V1/50/V - M8X15	LOCK V1/50/V - M8X15
2436	TUBO ARMORVIN HNA D.16	PIPE ARMORVIN HNA D.16
2459	TRECCIA POLIESTERE PAPO5	POLYESTER ROPE
2472	CAVO BATTERIA + L=1250	CABLE BATTERY + L=1250
2518	TELAIO FLOOR10 DOPPIA LAMA	CHASSIS FOR DOUBLEBLADE FLOOR10
2519	CARTER DISCO FLOOR 10 BILAMA	DISK CARTER FLOOR 10 DOUBLE BLADE
2559	PIASTRINO PER CHIUSURA CARTER	PLATE FOR CLOSER CARTER
2563	PIASTRA PER CHIUSURA CARTER DISCO	PLATE FOR CLOSER DISK CARTER
2573	TUBO RAFFREDDAMENTO DISCO	PIPE DISC COOLING
2607	BATTERIA 12V 35AH EUROSTAR DX	BATTERY 12V 35AH EUROSTAR DX



FLOOR 10

**TABLE
TAVOLA B**

MOTORE HONDA
MOTORE B&S
MOTORE ROBIN
MOTORE KOHLER
MOTORE LOMBARDINI

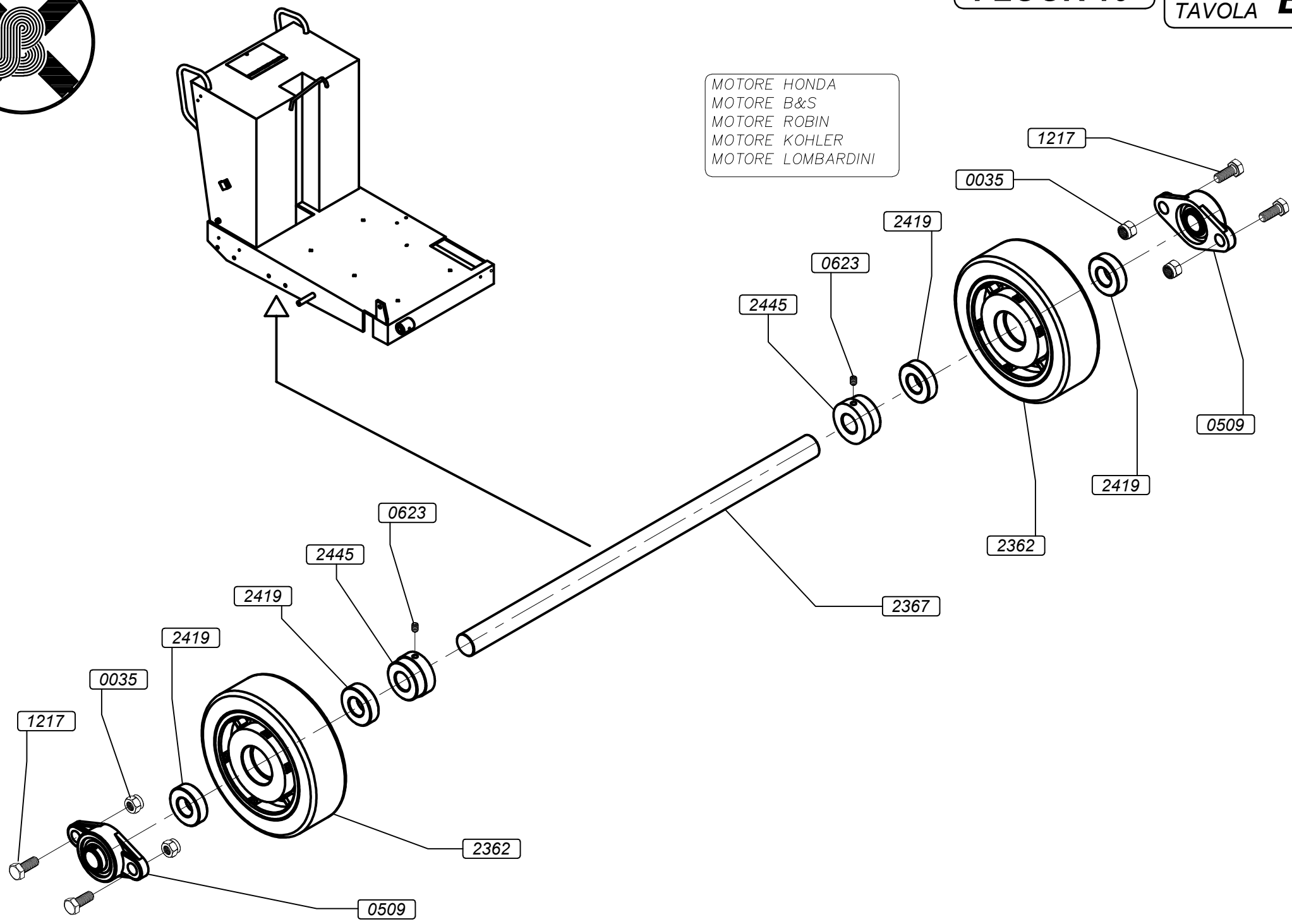

COD.	DESCRIZIONE (I)	DESCRIPTION (GB)
0035	DADO BLOKM10 -985 - Z.B.	SELF-LOCKING NUT M10 -985 Z.P.
0509	SUPPORTO UCFL 204 FK	SUPPORT UCFL 204 FK
0623	GRANO M8x10 - 5927	DOWEL M8X10 - 5927
1217	VITE TE 10X30 UNI 5739 Z.B.	SOCKET HEAD CAP BOLT M10X30 UNI 5739 Z. P.
2362	RUOTA ALLUMINIO C/RIV.GOMMA 160X50	RUBBER WHEEL ALUMINIUM 160X50
2367	ALBERO POS.RUOTE D.20 L=435	WHEEL SHAFT Ø20 L=435
2419	CUSCINETTO 62042RS (47-20-14)	BEARING 62042RS (47-20-14)
2445	DISTANZIALE PER FLOOR 10-20	SPACER FOR FLOOR 10 - FLOOR 20



MOTORE HONDA
MOTORE B&S
MOTORE ROBIN
MOTORE KOHLER
MOTORE LOMBARDINI

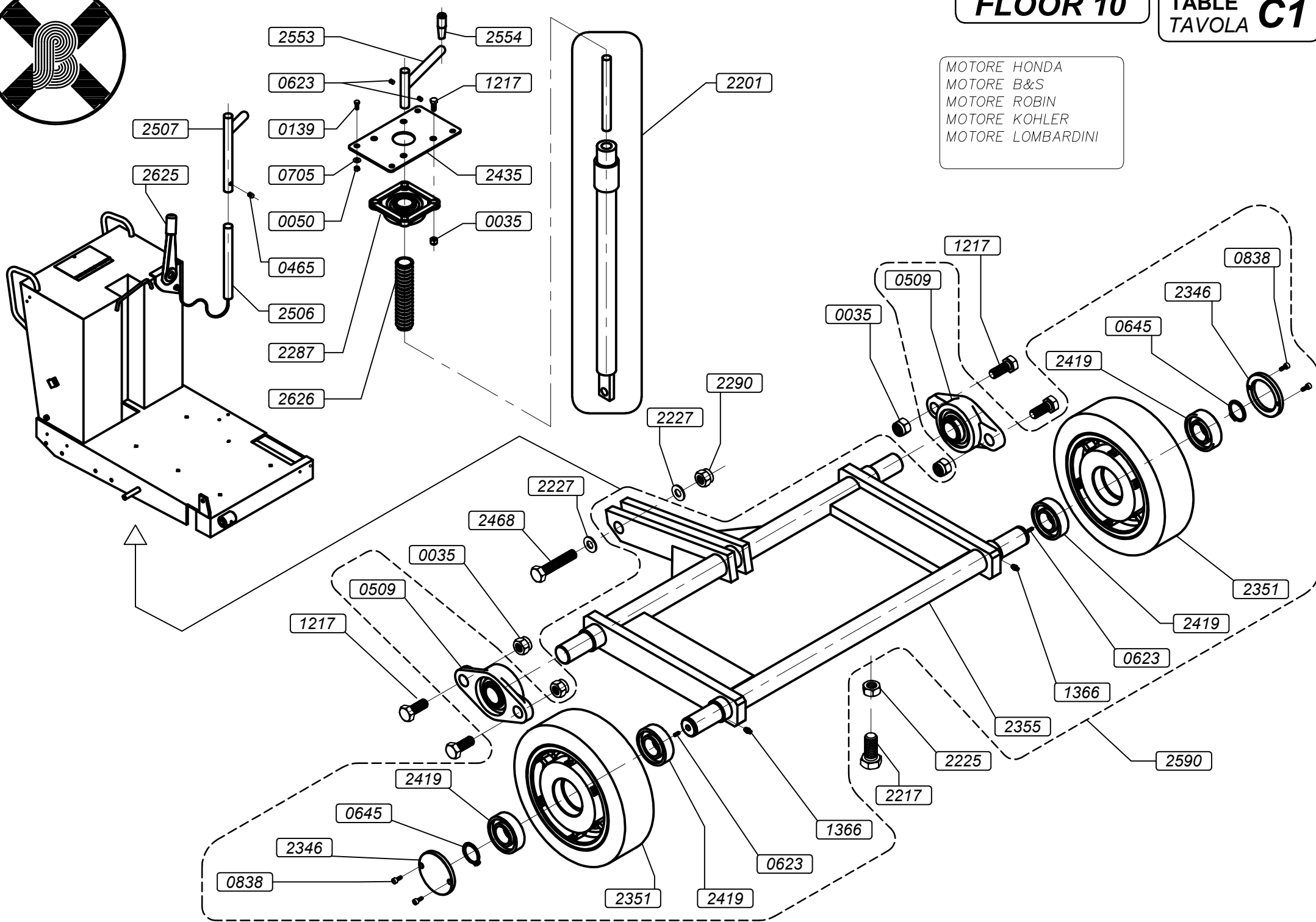

COD.	DESCRIZIONE (I)	DESCRIPTION (GB)
0035	DADO BLOKM10 -985 - Z.B.	SELF-LOCKING NUT M10 -985 Z.P.
0050	DADO BLOKM8 DIN 985 Z.B.	SELF-LOCKING NUT M8 DIN 985 Z.P.
0139	VITE TE 8x16 UNI 5739 Z.B.	SCREW HEX HEAD 8x16 UNI 5739 Z.P.
0465	GRANO M6x8 -5927	PIN M6x8 -5927
0509	SUPPORTO UCFL 204 FK	SUPPORT UCFL 204 FK
0623	GRANO M8x10 - 5927	DOWEL M8X10 - 5927
0645	SEEGER "E" 20 - 7435	SEEGER "E" 20 - 7435
0705	RONDELLA PIANA D. 8 Z.B.	WASHER D. 8 ZINC PLATED
0838	VITE TCCE 4X10 5931	SCREW TCCE4x10 5931
1217	VITE TE 10X30 UNI 5739 Z.B.	SOCKET HEAD CAP BOLT M10X30 UNI 5739 ZINC PLATED
1366	INGRASSATORE M8X1,25	GREASE FITTING M8X1,25
2201	CHIOCCIOLA+VITE 30 TPF 3X300 TIRANTE	TIEROD 30 TPF 3X300
2217	VITE TE 16X50 UNI 5737 Z.B.	HEX HEAD BOLT 16X50 UNI 5737 Z.P.
2225	DADO M16 UNI 5589 Z.B.	NUT M16 UNI 5589 Z.P.
2227	RONDELLA 16x30 Z.B.	WASHER 16x30 Z.P.
2287	SUPPORTO CUSCINETTO UCF 206	BEARING SUPPORT UCF 206
2290	DADO BLOK M16 DIN 985 Z.B.	SELF-LOCKING NUT M16 DIN 985 Z.P.
2346	COPERCHIO RUOTA D.65 Z.B.	WHEEL COVER D.65
2351	RUOTA GHISA 125X40 SEDE D.47	CAST-IRON WHEEL 125X40 SEDE D.47
2355	CARRELLO FLOOR 10	FLOOR 10 TROLLEY
2419	CUSCINETTO 62042RS (47-20-14)	BEARING 62042RS (47-20-14)
2435	PIASTRA SUPPORTO VOLANTINO	SUPPORT PLATE
2468	VITE TE 16X60 UNI 5737 Z.B.	SCREW TE 16X60 UNI 5737 Z.B.
2506	ARRESTO VOLANTINO F.10-20 Z.B.	HANDWHEEL STOP FLOOR 10/20
2507	SUPPORTO ARRESTO VOLANTINO	HANDWHEEL STOP SUPPORT
2553	MANOVELLA FLOOR 10/20/30	CRANK FLOOR 10/20/30
2554	MANOPOLA GIREVOLE MG85XM10	REVOLVING CRANK MG95XM10
2590	GRUPPO CARRELLO FLOOR 10	TROLLEY GROUP FLOOR 10
2625	BLOCCA VOLANTINO PER FLOOR	HANDWHEEL STOP SUPPORT
2626	CUFFIA PROTEZIONE CARDANO PER FLOOR	CARDAN PROTECTION COVER FOR FLOOR



FLOOR 10 HM

TABLE TAVOLA C2

- MOTORE HONDA
- MOTORE B&S
- MOTORE ROBIN
- MOTORE KOHLER
- MOTORE LOMBARDINI

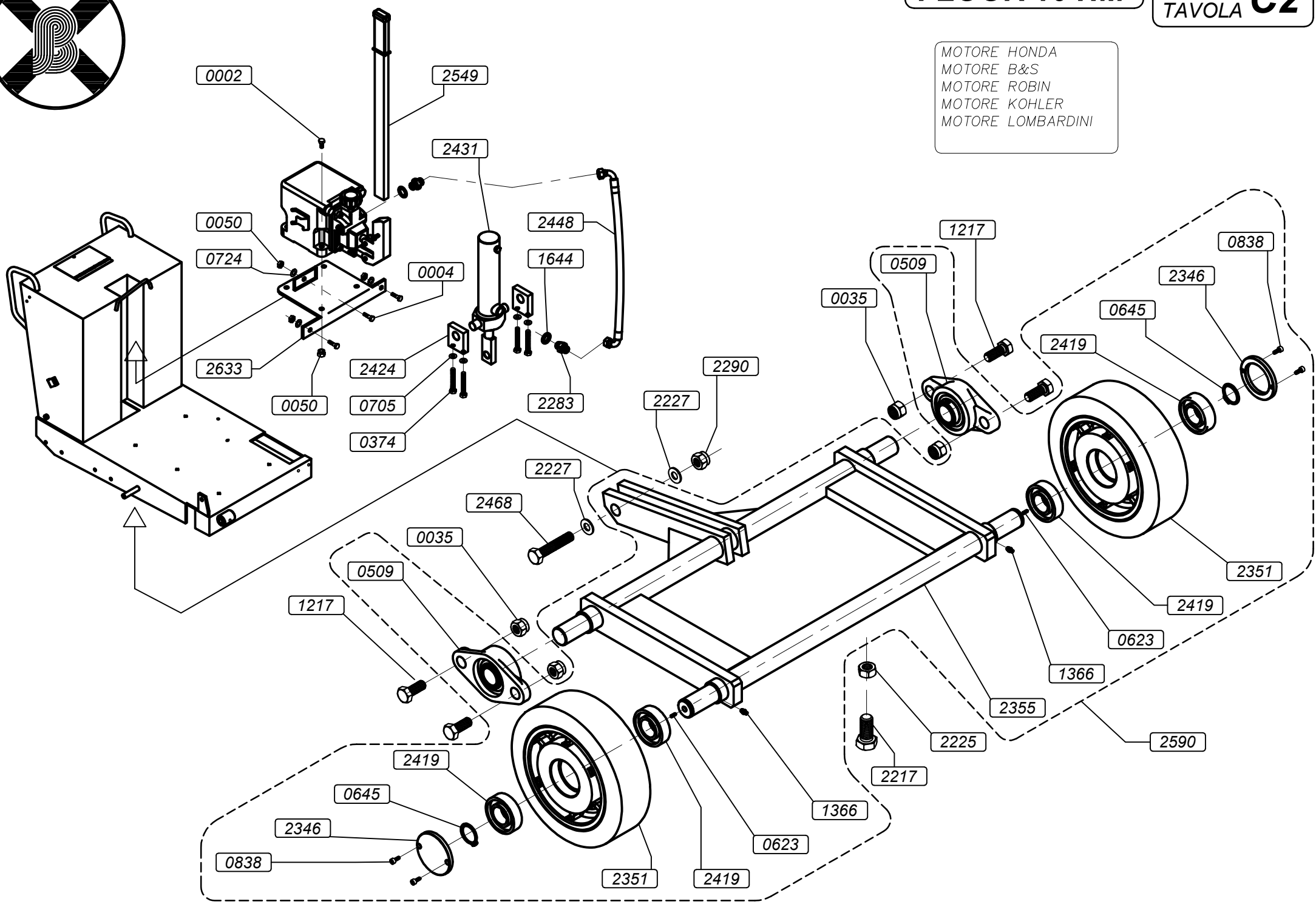

COD.	DESCRIZIONE (I)	DESCRIPTION (GB)
0002	VITE TE 8x35 UNI 5737 Z.B.	HEX HEAD BOLT 8x35 UNI 5737 Z.P.
0004	VITE TE 8x20 UNI 5739 Z.B.	HEX HEAD BOLT 8x20 UNI 5739 Z.P.
0035	DADO BLOKM10 -985 - Z.B.	SELF-LOCKING NUT M10 -985 Z.P.
0050	DADO BLOKM8 DIN 985 Z.B.	SELF-LOCKING NUT M8 DIN 985 Z.P.
0374	VITE TE 8x70 - 5737 - Z.B.	SCREW 8X70 5737
0509	SUPPORTO UCFL 204 FK	SUPPORT UCFL 204 FK
0623	GRANO M8x10 - 5927	DOWEL M8X10 - 5927
0645	SEEGER "E" 20 - 7435	SEEGER "E" 20 - 7435
0705	RONDELLA PIANA D. 8 Z.B.	WASHER D. 8 ZINC PLATED
0724	RONDELLA 8x24 - ZINCATA BIANCA	WASHER 8x24 - ZINC PLATED
0838	VITE TCCE 4X10 5931	SCREW TCCE4x10 5931
1217	VITE TE 10X30 UNI 5739 Z.B.	SOCKET HEAD CAP BOLT M10X30 UNI 5739 Z.P.
1366	INGRASSATORE M8X1,25	GREASE FITTING M8X1,25
1644	RONDELLA RAME 3/8"(17X22X1,5)	COPPER WASHER 3/8"(17X22X1,5)
2217	VITE TE 16X50 UNI 5737 Z.B.	HEX HEAD BOLT 16X50 UNI 5737 Z.P.
2225	DADO M16 UNI 5589 Z.B.	NUT M16 UNI 5589 Z.P.
2227	RONDELLA 16x30 Z.B.	WASHER 16x30 Z.P.
2283	NIPLES M-M 3/8"	NIPLES M-M 3/8"
2290	DADO BLOK M16 DIN 985 Z.B.	SELF-LOCKING NUT M16 DIN 985 Z.P.
2346	COPERCHIO RUOTA D.65 Z.B.	WHEEL COVER D.65
2351	RUOTA GHISA 125X40 SEDE D.47	CAST-IRON WHEEL 125X40 D.47
2355	CARRELLO FLOOR 10	FLOOR 10 TROLLEY
2419	CUSCINETTO 62042RS (47-20-14)	BEARING 62042RS (47-20-14)
2424	PIASTRA ATTAC.CILIND.C/BASCULA	CYLINDER COUPLING PLATE 100X50X15F.D.20
2431	CILINDRO C/BASCUL.FLOOR 10/20/	OVERHEAD CYLINDER
2448	TUBO FLEX R7 3/8"F.90 3/8"F.90	FLEX PIPE R7 3/8" F.90
2468	VITE TE 16X60 UNI 5737 Z.B.	SCREW TE 16X60 UNI 5737 Z.B.
2549	ASTA PER POMPA	ROD FOR PUMP
2590	GRUPPO CARRELLO FLOOR 10	TROLLEY GROUP FLOOR 10
2633	SUPPORTO POMPA HM ZINC.	PUMP SUPPORT HM Z.P.

FLOOR 10 HE

TABLE TAVOLA C3



MOTORE HONDA
MOTORE B&S
MOTORE ROBIN
MOTORE KOHLER
MOTORE LOMBARDINI

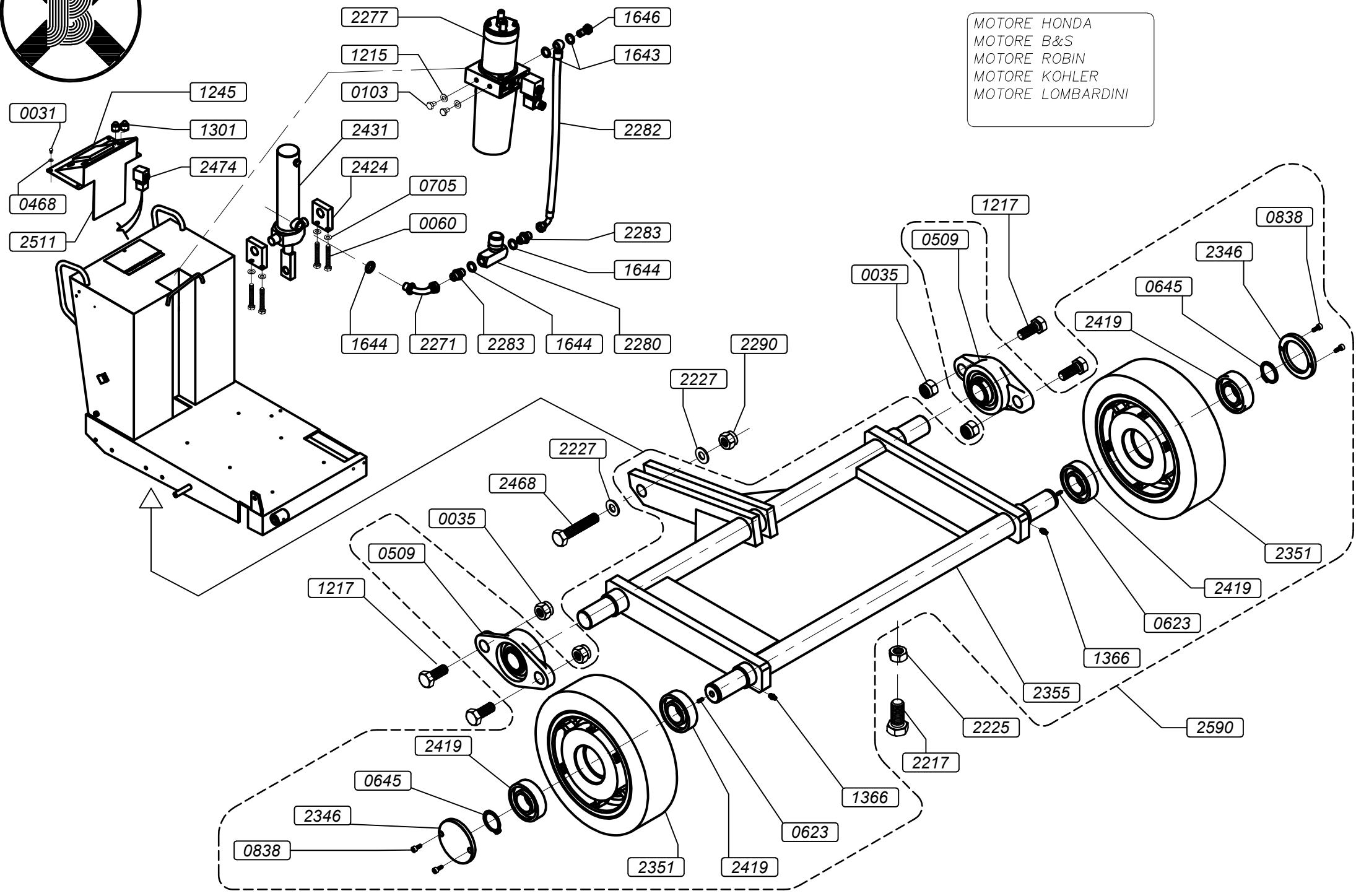

COD.	DESCRIZIONE (I)	DESCRIPTION (GB)
0031	VITE TCCE 6x10 5931 Z.B.	SOCKET CAP SCREW 6x10 5931
0035	DADO BLOKM10 -985 - Z.B.	SELF-LOCKING NUT M10 -985 Z.P.
0060	VITE TE 8x25 - 5739 - Z.B.	HEXAGONAL SCREW 8X25 5739
0103	VITE TE 10x16 -5739 - Z.B.	HEXAGONAL SCREW 10X16 5739
0468	RONDELLA 6x18X1,5 Z.B.	PLAIN WASHER 6x18X1,5
0509	SUPPORTO UCFL 204 FK	SUPPORT UCFL 204 FK
0623	GRANO M8x10 - 5927	DOWEL M8X10 - 5927
0645	SEEGER "E" 20 - 7435	SEEGER "E" 20 - 7435
0705	RONDELLA PIANA D. 8 Z.B.	WASHER D. 8 ZINC PLATED
0838	VITE TCCE 4X10 5931	SCREW TCCE4x10 5931
1215	RONDELLA PIANA 10x30 Z.B.	WASH PLAIN 10x30 Z.B.
1217	VITE TE 10X30 UNI 5739 Z.B.	SOCKET HEAD CAP BOLT M10X30 UNI 5739 Z.P.
1245	CONTAORE PER HCS RIF. 08174-ZL8-000HE	HOUR COUNTER TINY-TACH 2C HCS
1301	INTERRUTTORE ACQUA DOPPIE	WATER SWITCH FOR DOUBLE MACH.
1366	INGRASSATORE M8X1,25	GREASE FITTING M8X1,25
1643	RONDELLA RAME 13,5X19X1,5 (1/4")	COPPER WASHER 1/4"(13,5X19X1,5)
1644	RONDELLA RAME 3/8"(17X22X1,5)	COPPER WASHER 3/8"(17X22X1,5)
1646	BULLONE FORATO GAS 1/4" CH.19	BOLT 1/4" CH.19
2217	VITE TE 16X50 UNI 5737 Z.B.	HEX HEAD BOLT 16X50 UNI 5737 Z.P.
2225	DADO M16 UNI 5589 Z.B.	NUT M16 UNI 5589 Z.P.
2227	RONDELLA 16x30 Z.B.	WASHER 16x30 Z.P.
2271	RACCORDO 90^ M+F 3/8" DADO PINZATO GIREV	CONNECTION 90^ M+F 3/8"
2277	ELETTROP.-CENT.ME1/C40/AO/E67	CENTRAL ELECTRIC PUMP
2280	VALVOLA REGOLAZ. FT.257/5-3/8" UNIDIR.	ADJUSTMENT VALVE
2282	TUBO FLEXR1AT 3/8" F.90 3/8"	FLEX PIPE 3/8"
2283	NIPLES M-M 3/8"	NIPLES M-M 3/8"
2290	DADO BLOK M16 DIN 985 Z.B.	SELF-LOCKING NUT M16 DIN 985 Z.P.
2346	COPERCHIO RUOTA D.65 Z.B.	WHEEL COVER D.65
2351	RUOTA GHISA 125X40 SEDE D.47	CAST-IRON WHEEL 125X40 D.47
2355	CARRELLO FLOOR 10	FLOOR 10 TROLLEY
2419	CUSCINETTO 62042RS (47-20-14)	BEARING 62042RS (47-20-14)
2424	PIASTRA ATTAC.CILIND.C/BASCULA	CYLINDER COUPLING PLATE 100X50X15F.D.20
2431	CILINDRO C/BASCUL.FLOOR 10/20/	OVERHEAD CYLINDER
2468	VITE TE 16X60 UNI 5737 Z.B.	SCREW TE 16X60 UNI 5737 Z.B.
2478	PULEGGIA SPA 90X4A	CAST-IRON PULLEY 90X4A D.25,4 H7
2511	QUADRO COMANDI PER FLOOR	CONTROL PANEL FOR FLOOR
2590	GRUPPO CARRELLO FLOOR 10	TROLLEY GROUP FLOOR 10

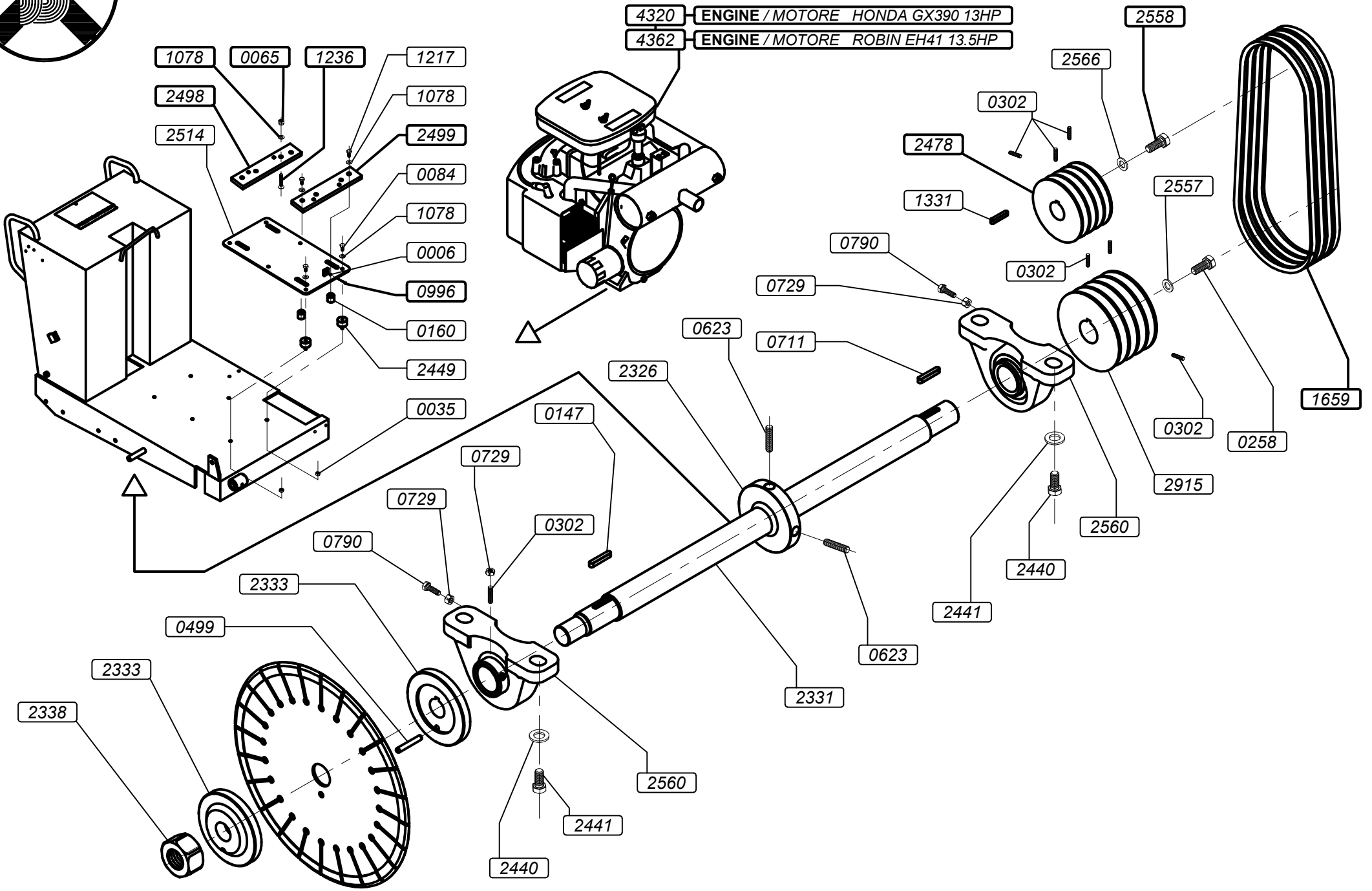

COD.	DESCRIZIONE (I)	DESCRIPTION (GB)
0006	DADO M8 UNI 5588 Z.B.	NUT M8 UNI 5588
0035	DADO BLOKM10 -985 - Z.B.	SELF-LOCKING NUT M10 -985 Z.P.
0065	DADO M10 5588 Z.B.	NUT M10 5588
0084	VITE TE 10x45 UNI 5737 Z.B.	HEXAGONAL SCREW 10X45
0147	CHIAVETTA6X6X15 UNI 6604	SMALL KEY 6X6X15 6604
0160	VITE TTDE10X30 UNI 5731 SENZA	HEXAGONAL SCREW 10X30 5731
0258	VITE TCCE 8x16 UNI 5931 Z.B. 12.9	SOCKET CAP SCREW 8X16 5931
0302	GRANO M6x16 - 5927	DOWEL M6X16 5927
0499	SPINA ELASTICA 6x30	SPRING PIN 6X30
0623	GRANO M8x10 - 5927	DOWEL M8X10 - 5927
0711	CHIAVETTA 6x6x30 - 6604A	SMALL KEY 6x6x30 - 6604A
0729	DADO M6 5589 BASSO Z.B.	LOW NUT M6 5589
0790	VITE TE 6x20 5739 Z.B.	SCREW TE 6x20 5739
0996	VITE TE 8x90 UNI 5739 DIN 933 Z.B.	SCREW TE 8x90 5739 ZB
1078	RONDELLA ZIGRIN. D10 ZINC. B.	PLAIN WASHER D.10
1217	VITE TE 10X30 UNI 5739 Z.B.	SOCKET HEAD CAP BOLT M10X30 UNI 5739 ZINC PLATED
1236	VITE VSP 10X50 Z.B.	SCREW VSP 10X50 Z.B.
1331	CHIAVETTA 38,1x6,3x6,3 B.& S	SMALL KEY 38,1X6,3X6,3 B.& S
1659	CINGHIA OPTIBELT XPA 807	BELT P.BELT XPA 807
2326	FLANGIA BLOCCALBERO	BLOCK SHAFT FLANGE
2331	ALBERO LAMA FLOOR 10 D.30-25,4	BLADE SHAFT FLOOR 10
2333	CONTROFLANGIA	COUNTERFLANGE
2338	DADO SX ALBERO LAMA FLOOR 10-	LEFT BLADE SHAFT NUT
2440	VITE TE 16X30 UNI 5739 Z.B.	SCREW TE 16X30 UNI 5739 Z.B.
2441	RONDELLA ZIGRINATA D.16 Z.B.	WASHER D.16
2449	DISTANZIALE PVC D.50-20 D.10.5	SPACER D.50-20 D.10.5
2478	PULEGGIA SPA 90X4A	CAST-IRON PULLEY 90X4A D.25,4 H7
2498	STAFFA MOT.ANT.50X12 L=250 ALL	FRONT ENGINE BRACKET
2499	STAFFA MOT.POST.50X12 L=250 AL	REAR ENGINE BRACKET
2514	PIASTRA SUPPORTO MOTORE BENZ.	GASOLINE ENGINE PLATE SUPPORT
2557	RONDELLA FISSAGGIO PULEGGIA	PULLEY FIXING WASHER
2558	VITE TE UNF 3/8 X 1"	SCREW TE UNF 3/8 X 1"
2560	SUPPORTO UCP 206 D.30 GHISA NTN	SUPPORT UCP 206 D.30
2566	RONDELLA PIANA 12x36 sp.2.5 6593 Z.B.	WASHER 12x36 TH. 2.5 6593
2915	PULEGGIA SPA 100X4 PER BUSSOLA 1615 F35	PULLEY 100X4

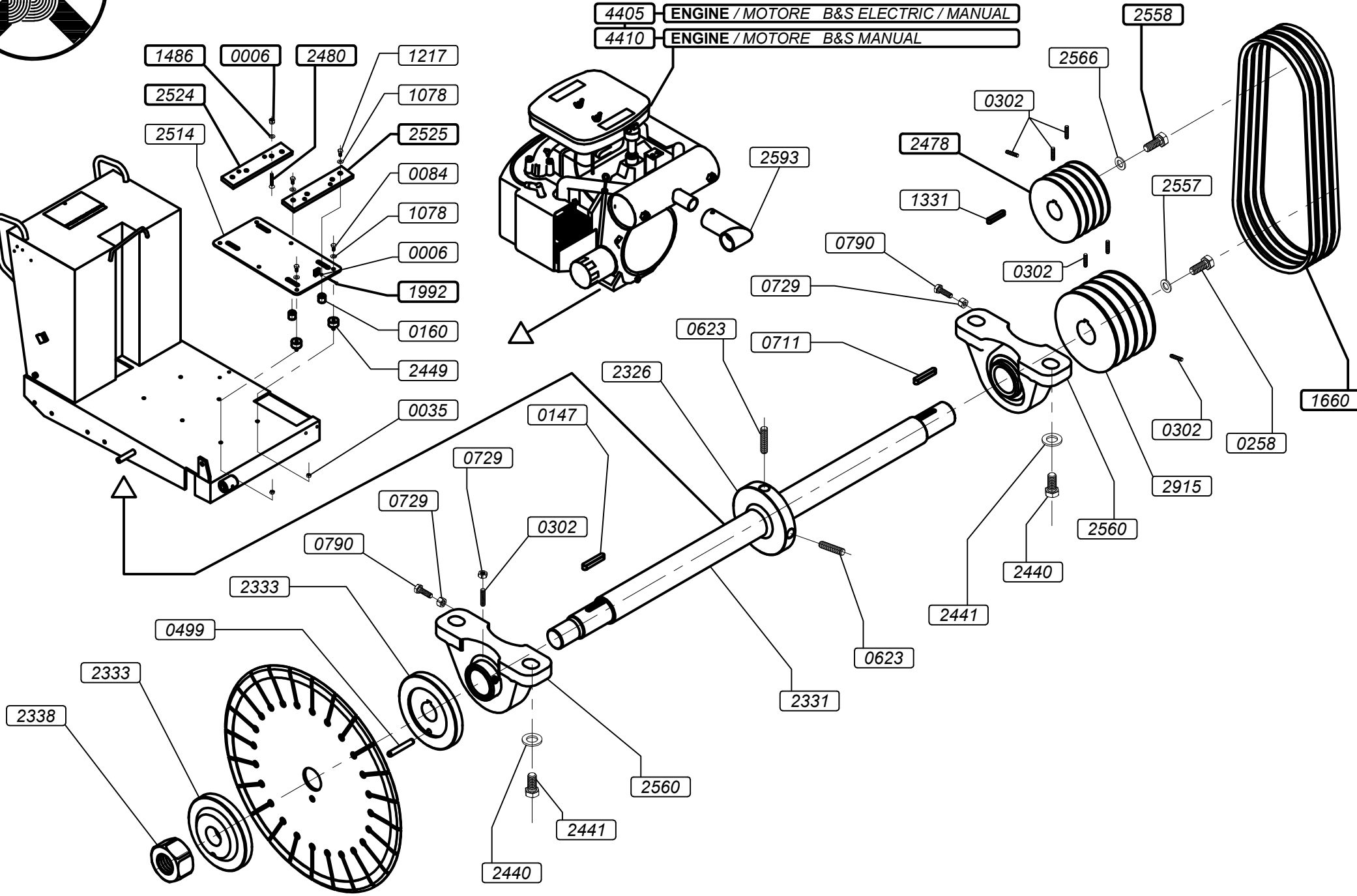

COD.	DESCRIZIONE (I)	DESCRIPTION (GB)
0006	DADO M8 UNI 5588 Z.B.	NUT M8 UNI 5588
0035	DADO BLOKM10 -985 - Z.B.	SELF-LOCKING NUT M10 -985 Z.P.
0084	VITE TE 10x45 UNI 5737 Z.B.	HEXAGONAL SCREW 10X45
0147	CHIAVETTA6X6X15 UNI 6604	SMALL KEY 6X6X15 6604
0160	VITE TTDE10X30 UNI 5731 SENZA	HEXAGONAL SCREW 10X30 5731
0258	VITE TCCE 8x16 UNI 5931 Z.B. 12.9	SOCKET CAP SCREW 8X16 5931
0302	GRANO M6x16 - 5927	DOWEL M6X16 5927
0499	SPINA ELASTICA 6x30	SPRING PIN 6X30
0623	GRANO M8x10 - 5927	DOWEL M8X10 - 5927
0711	CHIAVETTA 6x6x30 - 6604A	SMALL KEY 6x6x30 - 6604A
0729	DADO M6 5589 BASSO Z.B.	LOW NUT M6 5589
0790	VITE TE 6x20 5739 Z.B.	SCREW TE 6x20 5739
1078	RONDELLA ZIGRIN. D10 ZINC. B.	PLAIN WASHER D.10
1217	VITE TE 10X30 UNI 5739 Z.B.	SOCKET HEAD CAP BOLT M10X30 UNI 5739 ZINC PLATED
1331	CHIAVETTA 38,1x6,3x6,3 B.& S	SMALL KEY 38,1X6,3X6,3 B.& S
1486	RONDELLA ZIGRINATA D.8 Z.B.	WASH PLAIN D.8
1660	CINGHIA OPTIBELT XPA 832	BELT P.BELT XPA 832
1992	VITE TE 8X70 UNI 5739 Z.B.	SCREW TE 8X70 UNI 5739
2326	FLANGIA BLOCCALBERO	BLOCK SHAFT FLANGE
2331	ALBERO LAMA FLOOR 10 D.30-25,4	BLADE SHAFT FLOOR 10
2333	CONTROFLANGIA	COUNTERFLANGE
2338	DADO SX ALBERO LAMA FLOOR 10-	LEFT BLADE SHAFT NUT
2440	VITE TE 16X30 UNI 5739 Z.B.	SCREW TE 16X30 UNI 5739 Z.B.
2441	RONDELLA ZIGRINATA D.16 Z.B.	WASHER D.16
2449	DISTANZIALE PVC D.50-20 D.10.5	SPACER D.50-20 D.10.5
2478	PULEGGIA SPA 90X4A	CAST-IRON PULLEY 90X4A D.25,4 H7
2480	VITE VSP 8X50 5933 Z.B.	SCREW VSP 8X50 5933 Z.B.
2514	PIASTRA SUPPORTO MOTORE BENZ.	GASOLINE ENGINE PLATE SUPPORT
2524	STAFFA MOT.ANT.50X12 L=235 ALL	FRONT ENGINE BRACKET 50X12 L=235
2525	STAFFA MOT.POS.50X12 L=235 ALL	REAR ENGINE BRACKET 50X12 L=235
2557	RONDELLA FISSAGGIO PULEGGIA	PULLEY FIXING WASHER
2558	VITE TE UNF 3/8 X 1"	SCREW TE UNF 3/8 X 1"
2560	SUPPORTO UCP 206 D.30 GHISA NTN	SUPPORT UCP 206 D.30
2566	RONDELLA PIANA 12x36 sp.2.5 6593 Z.B.	WASHER 12x36 TH. 2.5 6593
2915	PULEGGIA SPA 100X4 PER BUSSOLA 1615 F35	PULLEY 100X4
2593	TUBO DEVIATORE SCARICO FUMI	EXHAUST PIPE
4405	MOTORE B&S 18HP C/SERB. A/E	B&S ENGINE 18HP ELECTRIC START
4410	MOTORE B&S 18HP C/SERB. A/M	B&S ENGINE 18HP MANUAL START

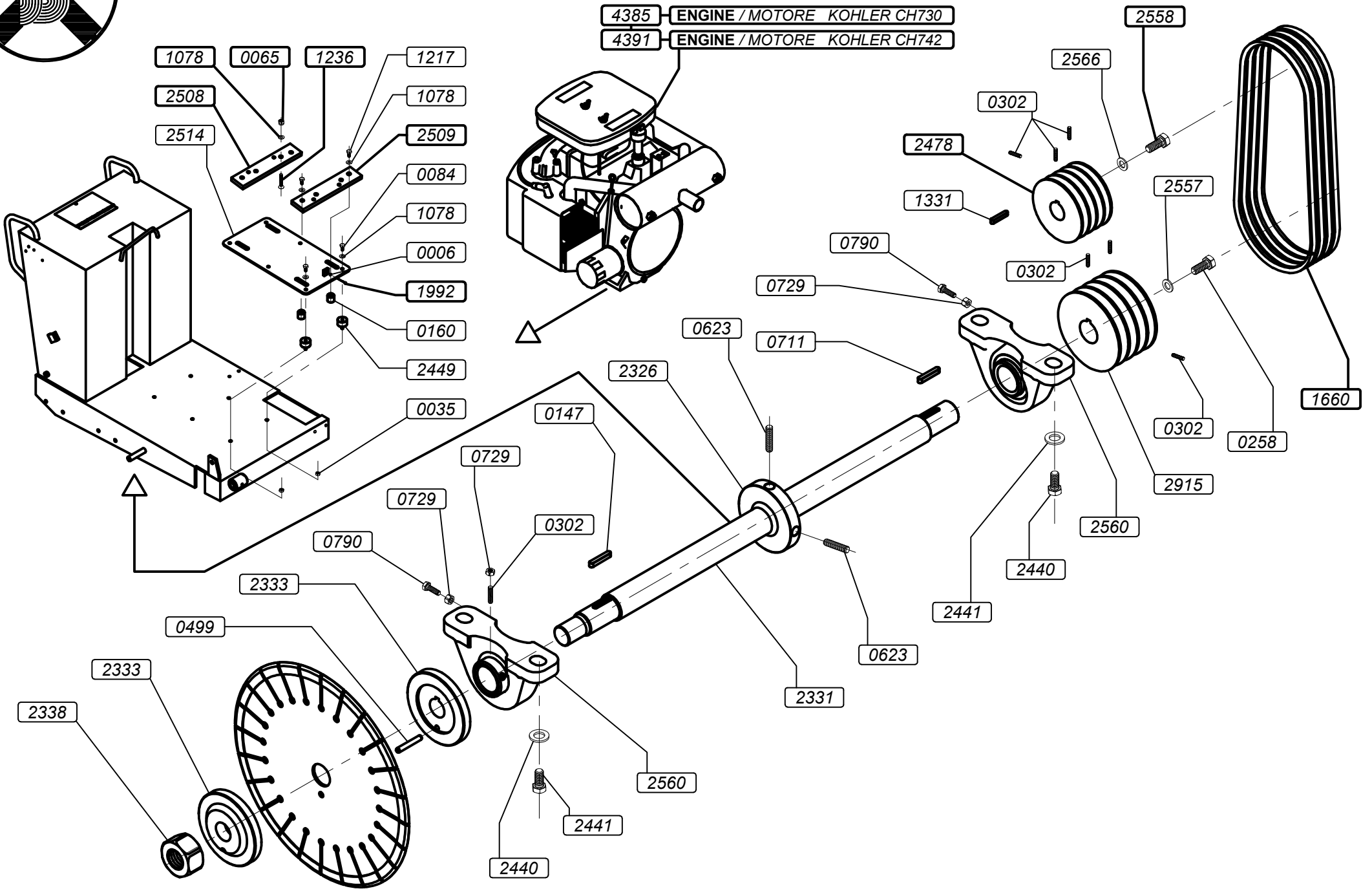

COD.	DESCRIZIONE (I)	DESCRIPTION (GB)
0006	DADO M8 UNI 5588 Z.B.	NUT M8 UNI 5588
0035	DADO BLOKM10 -985 - Z.B.	SELF-LOCKING NUT M10 -985 Z.P.
0065	DADO M10 5588 Z.B.	NUT M10 5588
0084	VITE TE 10x45 UNI 5737 Z.B.	HEXAGONAL SCREW 10X45
0147	CHIAVETTA6X6X15 UNI 6604	SMALL KEY 6X6X15 6604
0160	VITE TTDE10X30 UNI 5731 SENZA	HEXAGONAL SCREW 10X30 5731
0258	VITE TCCE 8x16 UNI 5931 Z.B. 12.9	SOCKET CAP SCREW 8X16 5931
0302	GRANO M6x16 - 5927	DOWEL M6X16 5927
0499	SPINA ELASTICA 6x30	SPRING PIN 6X30
0623	GRANO M8x10 - 5927	DOWEL M8X10 - 5927
0711	CHIAVETTA 6x6x30 - 6604A	SMALL KEY 6x6x30 - 6604A
0729	DADO M6 5589 BASSO Z.B.	LOW NUT M6 5589
0790	VITE TE 6x20 5739 Z.B.	SCREW TE 6x20 5739
1078	RONDELLA ZIGRIN. D10 ZINC. B.	PLAIN WASHER D.10
1217	VITE TE 10X30 UNI 5739 Z.B.	SOCKET HEAD CAP BOLT M10X30 UNI 5739 ZINC PLATED
1236	VITE VSP 10X50 Z.B.	SCREW VSP 10X50 Z.B.
1331	CHIAVETTA 38,1x6,3x6,3 B.& S	SMALL KEY 38,1X6,3X6,3 B.& S
1660	CINGHIA OPTIBELT XPA 832	BELT P.BELT XPA 832
1992	VITE TE 8X70 UNI 5739 Z.B.	SCREW TE 8X70 UNI 5739
2326	FLANGIA BLOCCALBERO	BLOCK SHAFT FLANGE
2331	ALBERO LAMA FLOOR 10 D.30-25,4	BLADE SHAFT FLOOR 10
2333	CONTROFLANGIA	COUNTERFLANGE
2338	DADO SX ALBERO LAMA FLOOR 10-	LEFT BLADE SHAFT NUT
2440	VITE TE 16X30 UNI 5739 Z.B.	SCREW TE 16X30 UNI 5739 Z.B.
2441	RONDELLA ZIGRINATA D.16 Z.B.	WASHER D.16
2449	DISTANZIALE PVC D.50-20 D.10.5	SPACER D.50-20 D.10.5
2478	PULEGGIA SPA 90X4A	CAST-IRON PULLEY 90X4A D.25,4 H7
2508	STAFFA MOTORE 50X12 L=240 ANT.	FRONT ENGINE BRACKET 50X12
2509	STAFFA MOTORE 50X12 L=240 POST.	REAR ENGINE BRACKET 50X12
2514	PIASTRA SUPPORTO MOTORE BENZ.	GASOLINE ENGINE PLATE SUPPORT
2557	RONDELLA FISSAGGIO PULEGGIA	PULLEY FIXING WASHER
2558	VITE TE UNF 3/8 X 1"	SCREW TE UNF 3/8 X 1"
2560	SUPPORTO UCP 206 D.30 GHISA NTN	SUPPORT UCP 206 D.30
2566	RONDELLA PIANA 12x36 sp.2.5 6593 Z.B.	WASHER 12x36 TH. 2.5 6593
2915	PULEGGIA SPA 100X4 PER BUSSOLA 1615 F35	PULLEY 100X4
4385	MOTORE KOHLER 23.5HP CH730	KOHLER ENGINE CH730 23.5HP
4391	MOTORE KOHLER 25HP CH742-3103	KOHLER ENGINE CH742 25 HP



- 4325 ENGINE / MOTORE HONDA GX630
- 4331 ENGINE / MOTORE HONDA GX690
- 4366 ENGINE / MOTORE ROBIN EH65

- HONDA GX630 2470
- HONDA GX690 2478
- ROBIN EH65 2478

- HONDA GX630 1660
- HONDA GX690 1660
- ROBIN EH65 1659

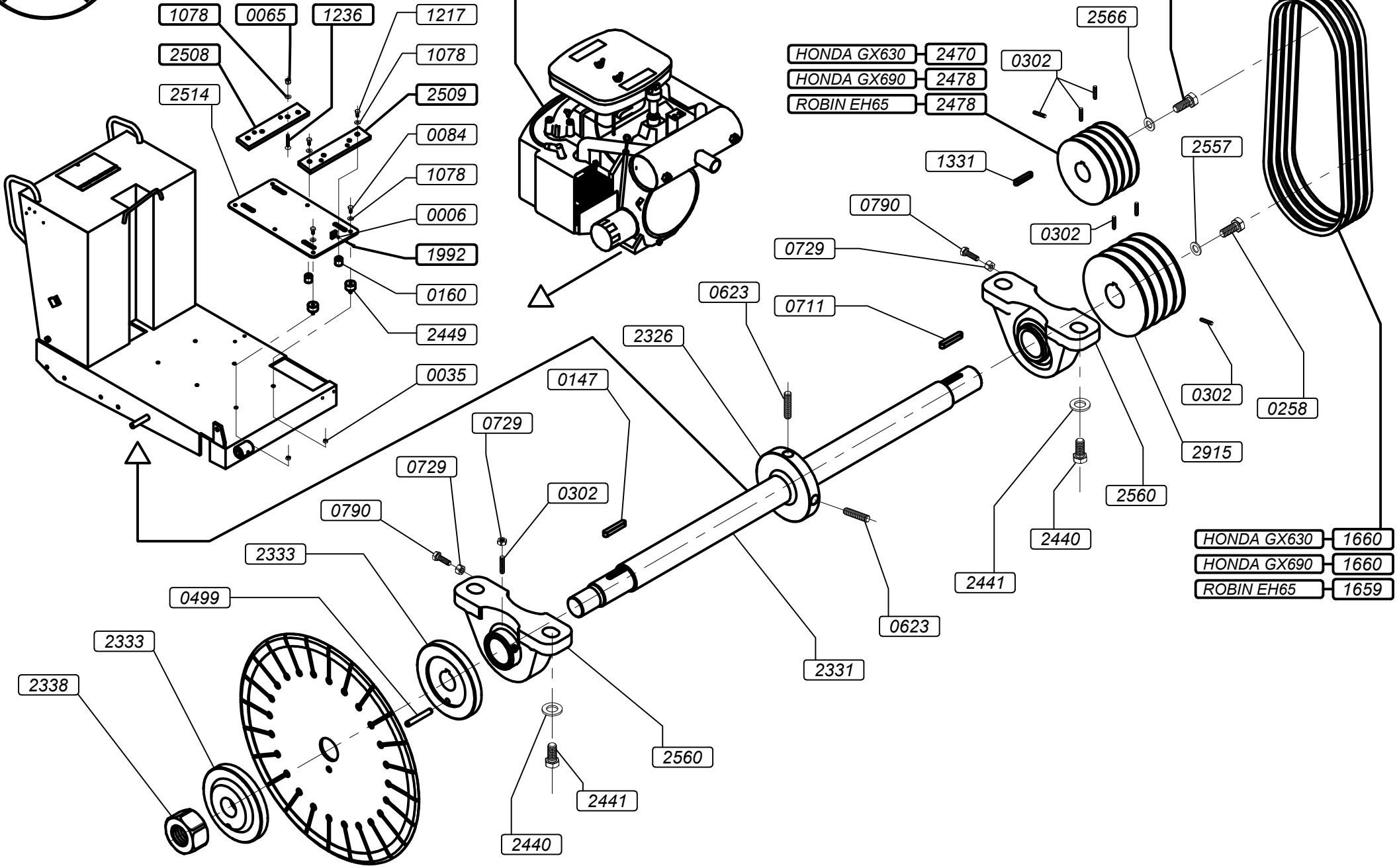

COD.	DESCRIZIONE (I)	DESCRIPTION (GB)
0006	DADO M8 UNI 5588 Z.B.	NUT M8 UNI 5588
0035	DADO BLOKM10 -985 - Z.B.	SELF-LOCKING NUT M10 -985 Z.P.
0065	DADO M10 5588 Z.B.	NUT M10 5588
0084	VITE TE 10x45 UNI 5737 Z.B.	HEXAGONAL SCREW 10X45
0147	CHIAVETTA6X6X15 UNI 6604	SMALL KEY 6X6X15 6604
0160	VITE TTDE10X30 UNI 5731 SENZA	HEXAGONAL SCREW 10X30 5731
0258	VITE TCCE 8x16 UNI 5931 Z.B. 12.9	SOCKET CAP SCREW 8X16 5931
0302	GRANO M6x16 - 5927	DOWEL M6X16 5927
0499	SPINA ELASTICA 6x30	SPRING PIN 6X30
0623	GRANO M8x10 - 5927	DOWEL M8X10 - 5927
0711	CHIAVETTA 6x6x30 - 6604A	SMALL KEY 6x6x30 - 6604A
0729	DADO M6 5589 BASSO Z.B.	LOW NUT M6 5589
0790	VITE TE 6x20 5739 Z.B.	SCREW TE 6x20 5739
1078	RONDELLA ZIGRIN. D10 ZINC. B.	PLAIN WASHER D.10
1217	VITE TE 10X30 UNI 5739 Z.B.	SOCKET HEAD CAP BOLT M10X30 UNI 5739 ZINC PLATED
1236	VITE VSP 10X50 Z.B.	SCREW VSP 10X50 Z.B.
1331	CHIAVETTA 38,1x6,3x6,3 B.& S	SMALL KEY 38,1X6,3X6,3 B.& S
1659	CINGHIA OPTIBELT XPA 807	BELT P.BELT XPA 807
1660	CINGHIA OPTIBELT XPA 832	BELT P.BELT XPA 832
1992	VITE TE 8X70 UNI 5739 Z.B.	SCREW TE 8X70 UNI 5739
2326	FLANGIA BLOCCALBERO	BLOCK SHAFT FLANGE
2331	ALBERO LAMA FLOOR 10 D.30-25,4	BLADE SHAFT FLOOR 10
2333	CONTROFLANGIA	COUNTERFLANGE
2338	DADO SX ALBERO LAMA FLOOR 10-	LEFT BLADE SHAFT NUT
2440	VITE TE 16X30 UNI 5739 Z.B.	SCREW TE 16X30 UNI 5739 Z.B.
2441	RONDELLA ZIGRINATA D.16 Z.B.	WASHER D.16
2449	DISTANZIALE PVC D.50-20 D.10.5	SPACER D.50-20 D.10.5
2470	PULEGGIA SPA90X4A C/BUSS. CONICA 1615 28	PULLEY SPA90X4A CONICAL 1615 28
2478	PULEGGIA SPA 90X4A	CAST-IRON PULLEY 90X4A D.25,4 H7
2508	STAFFA MOTORE 50X12 L=240 ANT.	FRONT ENGINE BRACKET 50X12
2509	STAFFA MOTORE 50X12 L=240 POST.	REAR ENGINE BRACKET 50X12
2514	PIASTRA SUPPORTO MOTORE BENZ.	GASOLINE ENGINE PLATE SUPPORT
2557	RONDELLA FISSAGGIO PULEGGIA	PULLEY FIXING WASHER
2558	VITE TE UNF 3/8 X 1"	SCREW TE UNF 3/8 X 1"
2560	SUPPORTO UCP 206 D.30 GHISA NTN	SUPPORT UCP 206 D.30
2566	RONDELLA PIANA 12x36 sp.2.5 6593 Z.B.	WASHER 12x36 TH. 2.5 6593
2915	PULEGGIA SPA 100X4 PER BUSSOLA 1615 F35	PULLEY 100X4
4325	MOTORE HONDA GX 630RH 20HP	HONDA ENGINE GX630 K1 20HP
4331	MOTORE HONDA GX690 RH	HONDA ENGINE GX690 27 HP
4366	MOTORE ROBIN/SUBARU EH65 22HP	ROBIN/SUBARU ENGINE EH65 22HP

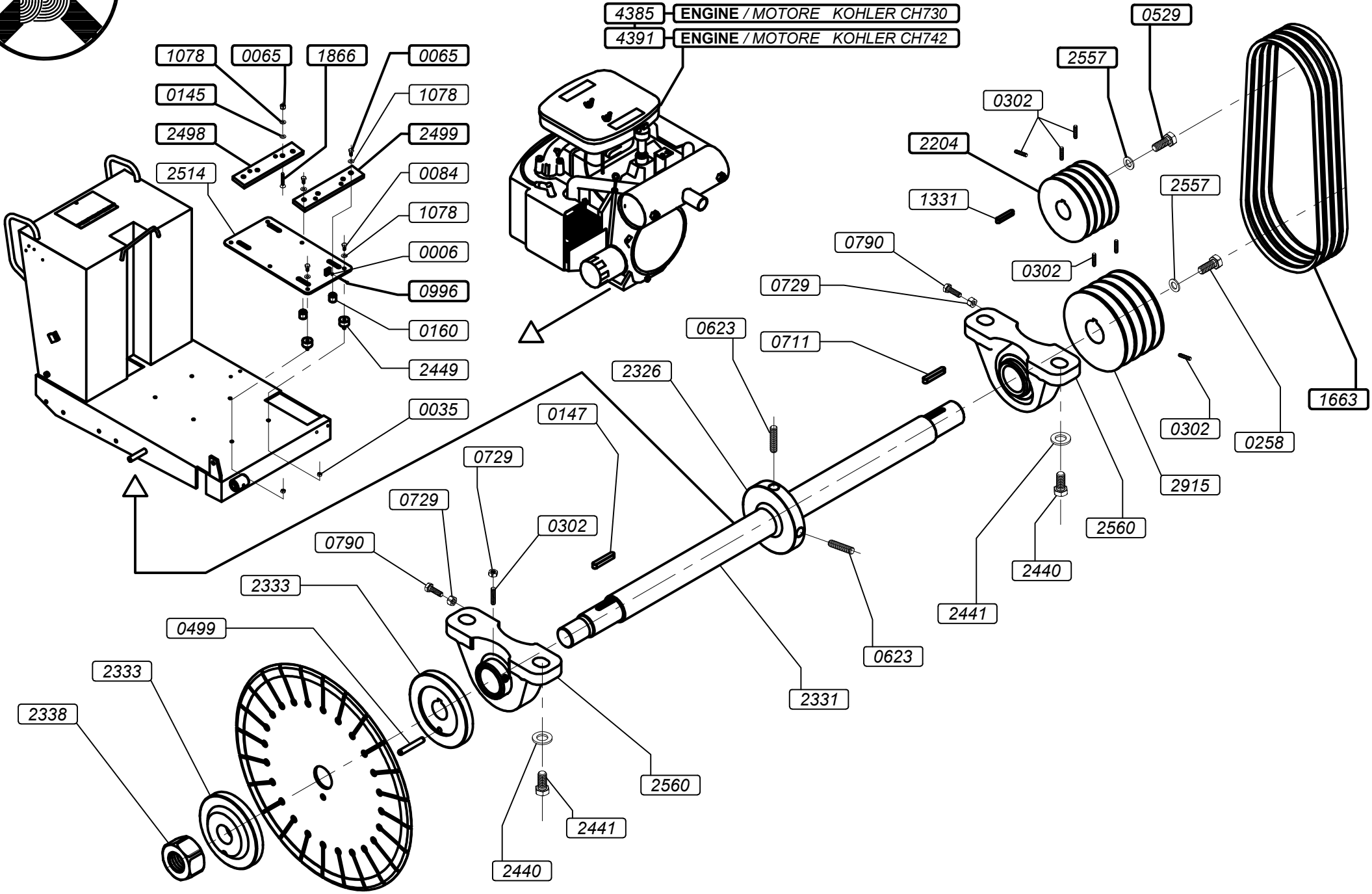

COD.	DESCRIZIONE (I)	DESCRIPTION (GB)
0006	DADO M8 UNI 5588 Z.B.	NUT M8 UNI 5588
0035	DADO BLOKM10 -985 - Z.B.	SELF-LOCKING NUT M10 -985 Z.P.
0065	DADO M10 5588 Z.B.	NUT M10 5588
0084	VITE TE 10x45 UNI 5737 Z.B.	HEXAGONAL SCREW 10X45
0145	RONDELLA PIANA 10x21 6592 Z.B.	PLAIN WASHER 10X21 6592.
0147	CHIAVETTA6X6X15 UNI 6604	SMALL KEY 6X6X15 6604
0160	VITE TTDE10X30 UNI 5731 SENZA	HEXAGONAL SCREW 10X30 5731
0258	VITE TCCE 8x16 UNI 5931 Z.B. 12.9	SOCKET CAP SCREW 8X16 5931
0302	GRANO M6x16 - 5927	DOWEL M6X16 5927
0499	SPINA ELASTICA 6x30	SPRING PIN 6X30
0529	VITE TE UNF 3/8x1"3/4	SCREW TE UNF 3/8x1"3/4
0623	GRANO M8x10 - 5927	DOWEL M8X10 - 5927
0711	CHIAVETTA 6x6x30 - 6604A	SMALL KEY 6x6x30 - 6604A
0729	DADO M6 5589 BASSO Z.B.	LOW NUT M6 5589
0790	VITE TE 6x20 5739 Z.B.	SCREW TE 6x20 5739
0996	VITE TE 8x90 UNI 5739 DIN 933 Z.B.	SCREW TE 8x90 5739 ZB
1078	RONDELLA ZIGRIN. D10 ZINC. B.	PLAIN WASHER D.10
1331	CHIAVETTA 38,1x6,3x6,3 B.& S	SMALL KEY 38,1X6,3X6,3 B.& S
1663	CINGHIA OPTIBELT XPA 882	BELT P.BELT XPA 882
1866	VITE VSP 10X55 Z.B. 5933	SCREW VSP 10X55 Z.B. 5933
2204	PULEGGIA GHISA 90X3A D.25,4 H7	CAST-IRON PULLEY 90X3A D.25,4 H7
2326	FLANGIA BLOCCALBERO	BLOCK SHAFT FLANGE
2331	ALBERO LAMA FLOOR 10 D.30-25,4	BLADE SHAFT FLOOR 10
2333	CONTROFLANGIA	COUNTERFLANGE
2338	DADO SX ALBERO LAMA FLOOR 10-	LEFT BLADE SHAFT NUT
2440	VITE TE 16X30 UNI 5739 Z.B.	SCREW TE 16X30 UNI 5739 Z.B.
2441	RONDELLA ZIGRINATA D.16 Z.B.	WASHER D.16
2449	DISTANZIALE PVC D.50-20 D.10.5	SPACER D.50-20 D.10.5
2498	STAFFA MOT.ANT.50X12 L=250 ALL	FRONT ENGINE BRACKET 50X12
2499	STAFFA MOT.POST.50X12 L=250 AL	REAR ENGINE BRACKET 50X12
2514	PIASTRA SUPPORTO MOTORE BENZ.	GASOLINE ENGINE PLATE SUPPORT
2557	RONDELLA FISSAGGIO PULEGGIA	PULLEY FIXING WASHER
2560	SUPPORTO UCP 206 D.30 GHISA NTN	SUPPORT UCP 206 D.30
2915	PULEGGIA SPA 100X4 PER BUSSOLA 1615 F35	PULLEY 100X4
4385	MOTORE KOHLER 23.5HP CH730	KOHLER ENGINE CH730 23.5HP
4391	MOTORE KOHLER 25HP CH742	KOHLER ENGINE CH742 25HP